

DO NOT MAKE COPIES OF THIS CD



84-88 Pontiac Fiero Parts & Illustrations CD

PONTIAC CHASSIS GROUP 0.000

ILLUSTRATION INDEX

TITLE	GRID
1984-1986 P ENGINE ASM-2.5L L4 PART 2 (LR8/2.5R)	H8
1984-1987 P ENGINE ASM-2.5L L4 PART 1 (LR8/2.5R)	H10
1987-1988 P ENGINE ASM-2.5L L4 PART 2 (LR8/2.5R)	H14
1988 P ENGINE ASM-2.5L L4 PART 1 (LR8/2.5R)	H17
1985-1988 P ENGINE ASM-2.8L V6 PART 1 (L44/2.8-9)	H20
1985-1988 P ENGINE ASM-2.8L V6 PART 2 (L44/2.8-9)	H23
1984 P ENGINE & TRANSMISSION MOUNTING	H25
1985 P ENGINE & TRANSMISSION MOUNTING	H27
1986-1988 P ENGINE & TRANSMISSION MOUNTING-L4 (LR8/2.5R)	I3
1986 P ENGINE & TRANSMISSION MOUNTING-V6 (L44/2.8-9)(MD9-A.T.)	I4
1986-1988 P ENGINE & TRANSMISSION MOUNTING-V6 (L44/2.8-9)(MT2-M.T.)	I6
1987-1988 P ENGINE & TRANSMISSION MOUNTING-V6 (L44/2.8-9)(MG2-M.T.)	I8
1984 P ENGINE INSULATORS & SPLASH SHIELDS	I10
1985 P ENGINE INSULATORS & SPLASH SHIELDS	I11
1986-1988 P ENGINE INSULATORS & SPLASH SHIELDS	I12
1984 P CLUTCH LINKAGE	I13
1985 P CLUTCH LINKAGE	I14
1986 P CLUTCH LINKAGE	I15
1987-1988 P CLUTCH LINKAGE	I16
1984-1988 P CLUTCH COVER & PLATE	I18
1984-1987 P CLUTCH & BRAKE PEDAL PARTS	I19
1988 P CLUTCH & BRAKE PEDAL PARTS	I20

DO NOT MAKE COPIES OF THIS CD

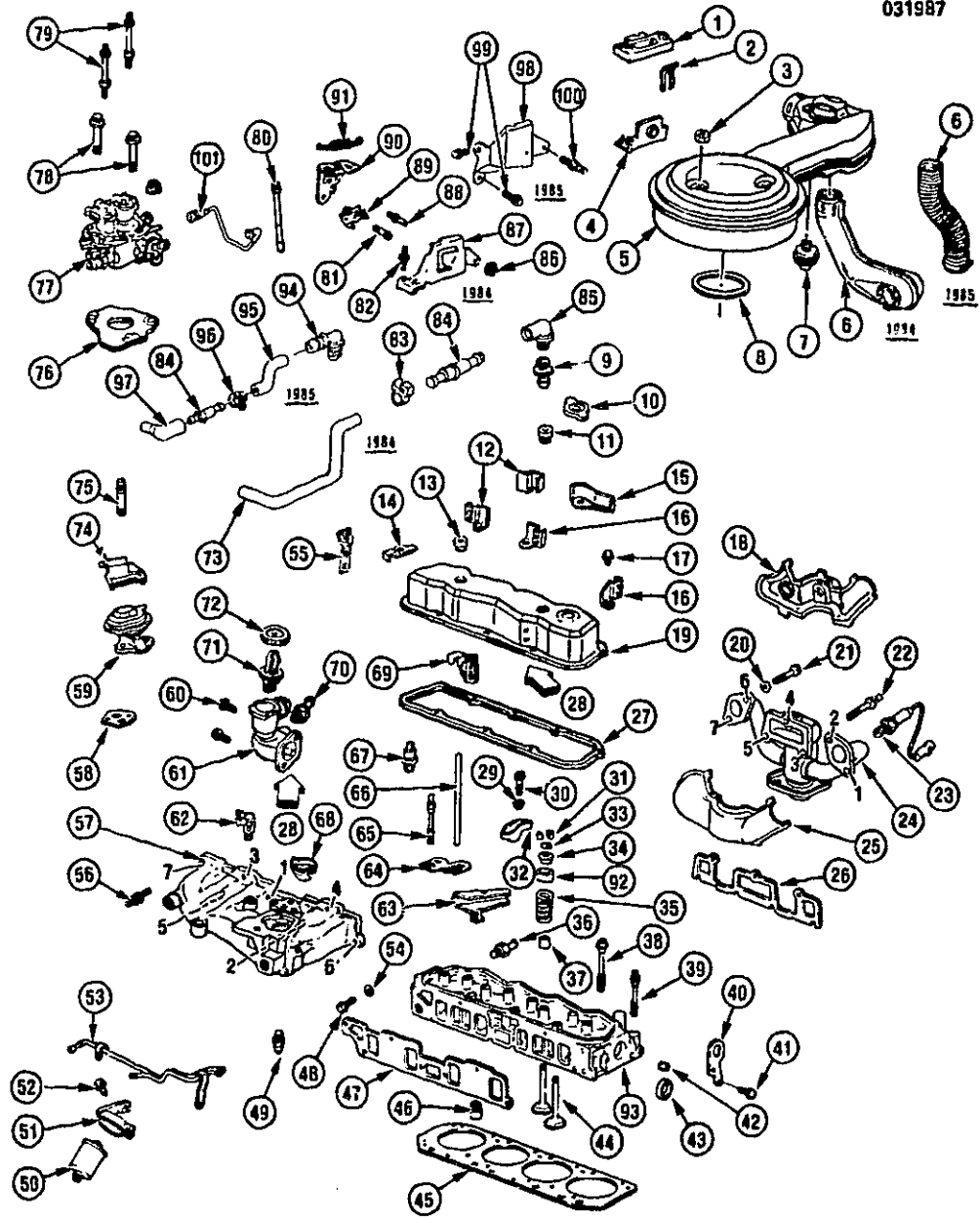

1984-1986 P ENGINE ASM-2.5L L4 PART 2 (LR8/2.5R)

1.	N15	3.682	SENSOR, M A P	16017460
2.	E15	1.745	RETAINER, "U" SHAPE (1 64 X 1 25)	22530004
3.	N11	3.403	NUT, A/CL (M6 X 1)	10031018
4.	N15	3.682	BRACKET, M A P SENSOR	10026710
5.	N11	3.402	AIR CLEANER, TB(CPS)(1)	25043307
	N11	3.410	ELEMENT(POLYWRAP)(A913C)	25043317
	N11	3.415	SENSOR,A/CL	6997574
	N11	3.415	MOTOR,A/CL DIAPH	25041109
	E15	1.745	GROMMET,CR/CASE OIL VENT SEP ON A/CL	25043008
6.	N12	3.417	TUBE, ENG AIR HT STOVE	10045291
7.	E15	1.745	SEPARATOR KIT, CR/CASE VENT OIL	25041743
8.	N11	3.403	SEAL, AIR CLEANER	10019832
9.	E15	1.745	CONNECTOR, C/CASE VENT VLV ELBOW (1984)	10030429
10.	E15	1.758	CAP, OIL FIL (FC104)	10044670
11.	E15	1.745	GROMMET, C/CASE VENT TO RKR CVR	10037288
12.	F14	2.183	BRACKET, IGN CBL HARN (EXH-FRT SI OF CVR)	10028845
13.	E15	1.745	GROMMET, C/CASE VENT TO RKR CVR	10037287
14.	G6	2.559	RETAINER, WIRING	20346032
15.	F14	2.183	BRACKET, IGN CBL HARN (INT SI OF CVR)	10028844
16.	F14	2.183	BRACKET, IGN CBL HARN (EXH & RR SI OF CVR)	10028846
17.		8.900	BOLT, FLG HEX HD (M6X1X14)(9 B PHOS)	14883759
18.	N12	3.417	STOVE, ENG AIR HT	10184939
19.	D9	0.388	COVER, W/BAFFLE, VLV RKR ARM	10044305
20.		8.931	WASHER,LK #10X18 30D(AR)	11500048
21.	N10	3.275	BOLT, EXH MANIF TO CYL HD (#1.2.5.6 & 7)(5)	10101343
		8.900	BOLT,HWH M10-1.5X25 10 9 PH(AR)	11508931
22.	N10	3.275	BOLT, EXH MANIF TO CYL HD (#3)(1)	15590518
23.	N15	3.682	SENSOR, EXH OXYGEN	8990741
24.	N13	3.601	MANIFOLD, EXH	10184915
25.	N12	3.417	STOVE, ENG AIR HT	10184939
26.	N10	3.270	GASKET, EXH MANIF	10101355
27.	D9	0.423	GASKET, VLV RKR ARM CVR	10101791
28.		8.800	SEALANT, SILICONE RTV	
29.	D9	0.429	BALL, ROCKER ARM	10000244
30.	D9	0.429	BOLT, RKR ARM BALL	10031032
31.	D9	0.310	KEY, VLV STEM	3947770
32.	D9	0.333	ARM, W/BALL, VLV RKR	10121095
33.	D9	0.308	SEAL, VLV STEM OIL (O RING TYPE)	3835333
34.	D9	0.309	CAP, INT VLV SPRING	10039209
35.	D9	0.303	SPRING, W/DAMPER, VALVE	3735381
36.	E6	1.055	SWITCH, FAN CONT	3040674
37.	D9	0.308	SEAL, W/RET, INL VLV STEM (STD .003" O S)	460483
38.	D9	0.293	BOLT,CYL HD LG(M11X1 5X93)	478543
39.	D9	0.293	STUD,CYL HD #5(11 X1 5X68/8X1 25X15)	10035947
40.	D9	0.004	BRACKET, ENG LIFT FRT	10004894
41.		8.900	BOLT,HEX FLG M10-1 5X20 9 8 PC(AR)	11502885
42.	N10	3.285	PLUG,INT MANIF LWR HOLE(1/2-14 SQ HOLE DRIVE)	25522466
43.		8.970	PLUG,WATER JACKET-SIDE DIAM 41 5MM(AR)	10000462
44.	D9	0.297	VALVE, EXH (STD)(2)	10034162
	D9	0.298	VALVE, INTAKE(STD)(2)	10022882
45.	D9	0.289	GASKET, CYL HEAD	10101784
46.	D9	0.459	LIFTER, VALVE(STD)	5234212
	D9	0.459	LIFTER,HYD VLV(010" O S)	5234390
47.	N10	3.270	GASKET, INT MANIF TO CYL HD	10026023
48.	N10	3.275	BOLT, INT MANIF TO HD (M8 X 1 25 X 30)(#1.2.6)	10005600
49.	N25	8.868	CONTROL, HTR CLNT HOSE CLNT	10028805
50.	N16	3.890	FILTER, FUEL (GF481)	25055052
51.	N16	3.890	CLAMP, FUEL FILTER	10039217
52.		8.915	NUT,HEX M8X1 25X7 8 10 1040MPA PC(0349)(AR)	22521550
53.	N8	3.120	PIPE, FUEL VPR CNSTR PURGE	10031713
54.		8.929	WASHER,FL M8X20X2 5 THK HARDENED STL COP(AR)	11501623
55.	N12	3.469	RETAINER, ACCEL CONT CBL	10029080
56.	N10	3.275	STUD (M8 X 1 25 X 30/M8 X 1 25 X 15)(#3.4.5)	10037828
	N10	3.275	BOLT, MANIF TO HD (M10 X 1 5 X 35/M8 X 1 25 X 25)(#7)	10018844
		8.929	WASHER,FL M8X20X2 5 THK HARDENED STL COP(AR)	11501623
57.	N10	3.285	MANIFOLD, INTAKE(1984-85)	10031385
	N10	3.285	MANIFOLD,INT(1986)	10039804
58.	N15	3.680	GASKET, EGR VLV TO PLENUM	10009588
59.	N13	3.670	VALVE, EGR	17110478
60.		8.900	BOLT,HFH M8X1 25X16 17 6-OD 9 8 PZOR(AR)	11507022
61.	E12	1.251	HOUSING, THERMOSTAT	10038440
62.	N11	3.278	FITTING, W/CAP, MANIF VAC (3/8".16 4 PORT)	10030771
	N11	3.278	CAP, INT MANIF VAC FTG (3 734)	525370

63.	E7	1.060	SHIELD, ENG COOL TEMP FAN CONT SW	10032484
64.	D9	0.439	GUIDE, VLV PUSH ROD(# 1)	10012916
	D9	0.439	GUIDE, VLV PUSH ROD(# 2)	10012916
	D9	0.439	GUIDE, VLV PUSH ROD(# 3)	10012917
	D9	0.439	GUIDE, VLV PUSH ROD(# 4)	10012918
65.	D9	0.293	STUD, HEX DBL END (11X1 5X100 & 10X1 5X18) STL 11 9	12338010
66.	D9	0.426	ROD, VALVE PUSH(#2)	10021838
67.	D9	0.448	STUD, W/SEAL PUSH ROD CVR(#2)	10004722
68.	N10	3.265	INSERT, INT MANIF	10022585
69.	E15	1.782	BRACKET, C/CASE VENT VLV HOSE (1984)	10028643
	E15	1.745	BRACKET, C/CASE VENT VLV HOSE GUIDE (1985 86)	10032421
70.	N15	3.682	SENSOR, COOLANT TEMP	10045547
71.	E12	1.248	THERMOSTAT, CLNT OTLT (195 DEG#2)	3059793
72.	E12	1.251	CAP, THERM HOUSING	8410941
73.		8.962	HOSE, C/CASE VENT VLV (3/8"X24"1984)	8439373
74.	N14	3.671	SHIELD, EGR VLV TO TPS	17111750
75.	N11	3.288	STUD, TBI TO INT MANIF (53 0 LG)	25809575
76.	N16	3.726	INSULATOR, TBI UNIT TO INT MANIF	10140578
77.	N16	3.725	THROTTLE BODY INJECTION(#1)	
78.		8.900	BOLT, HEX M8X1 25X80 10 9 PC(AR)	11800928
		8.929	WASHER, FLAT 5/16X5/8X1/16 ZP HARD(AR)	2438182
79.	N11	3.403	STUD, TBI TO AIR CLEANER	10038028
80.	N12	3.454	LINK, THROT CONT	10030583
81.	N12	3.454	BOLT, THROT CONT IDLER LVR	10020387
82.	N12	3.454	STUD, THROT LVR PROT (M8 X 1 25 X 14 M8 X 1 25 X 20)	10038671
83.		N.S.	CLAMP, HOSE TO VALVE	
84.	E15	1.745	VALVE, C/CASE VENT(#2)	25041498
85.	E15	1.782	ELBOW, C/CASE VENT VLV (1984)	10037288
	E15	1.782	ELBOW, CR/CASE VENT VLV (GROM TO HOSE)(1985 86)	10035911
86.		8.917	NUT, M10X1 5(AR)	11802812
87.	N12	3.454	PROTECTOR, THROT LVR (1984)	10038672
88.	N10	3.275	BOLT, BRKT TO INT MANIF (M10 X 1 5 X 56 5)(1984)	15598518
89.	N12	3.454	LEVER, THROT CONT IDLER	10029188
90.	N12	3.454	BRACKET, THROT & TRANS TV CBL(1984)	10028073
	N12	3.454	BRACKET, ACCEL & TRANS TV CBL(1985 86)	10038747
91.	N12	3.459	SPRING, THROT RETURN(#2)	10029402
92.	D9	0.308	SHIELD, VLV STEM OIL(1984-85)	10007816
93.	D9	0.269	HEAD ASM, CYLINDER(#2)	10038231
94.	E15	1.782	ELBOW, C/CASE VENT VLV (GROMMET TO HOSE)(1985 86)	10035911
95.	E15	1.782	HOSE, C/CASE VENT VLV TO ELBOW (1985 86)	10032420
96.		8.948	CLAMP, WORM GEAR 80X1 25 SLOTTED SCREWW LINER STL ZOR (1174) (AR)	711889
97.	E15	1.782	BOOT, C/CASE VENT VLV (1985 86)	10035943
98.	N12	3.454	PROTECTOR, THROT LVR (1985 86)	10035928
99.		8.900	BOLT, HFH (M8X1 25X20) 10 9 POR	11814343
100.		8.900	BOLT, HWH (M10 X 1 5 X 25)(1985 86)	11802788
101.		8.962	HOSE, FUEL OIL EVAP 5 32"X25 (AR)	8438381

NOTE 1 SEE RESPECTIVE GROUP FOR DETAILED ILLUSTRATED VIEW
NOTE 2 SEE CATALOG GROUP FOR ADDITIONAL USAGE

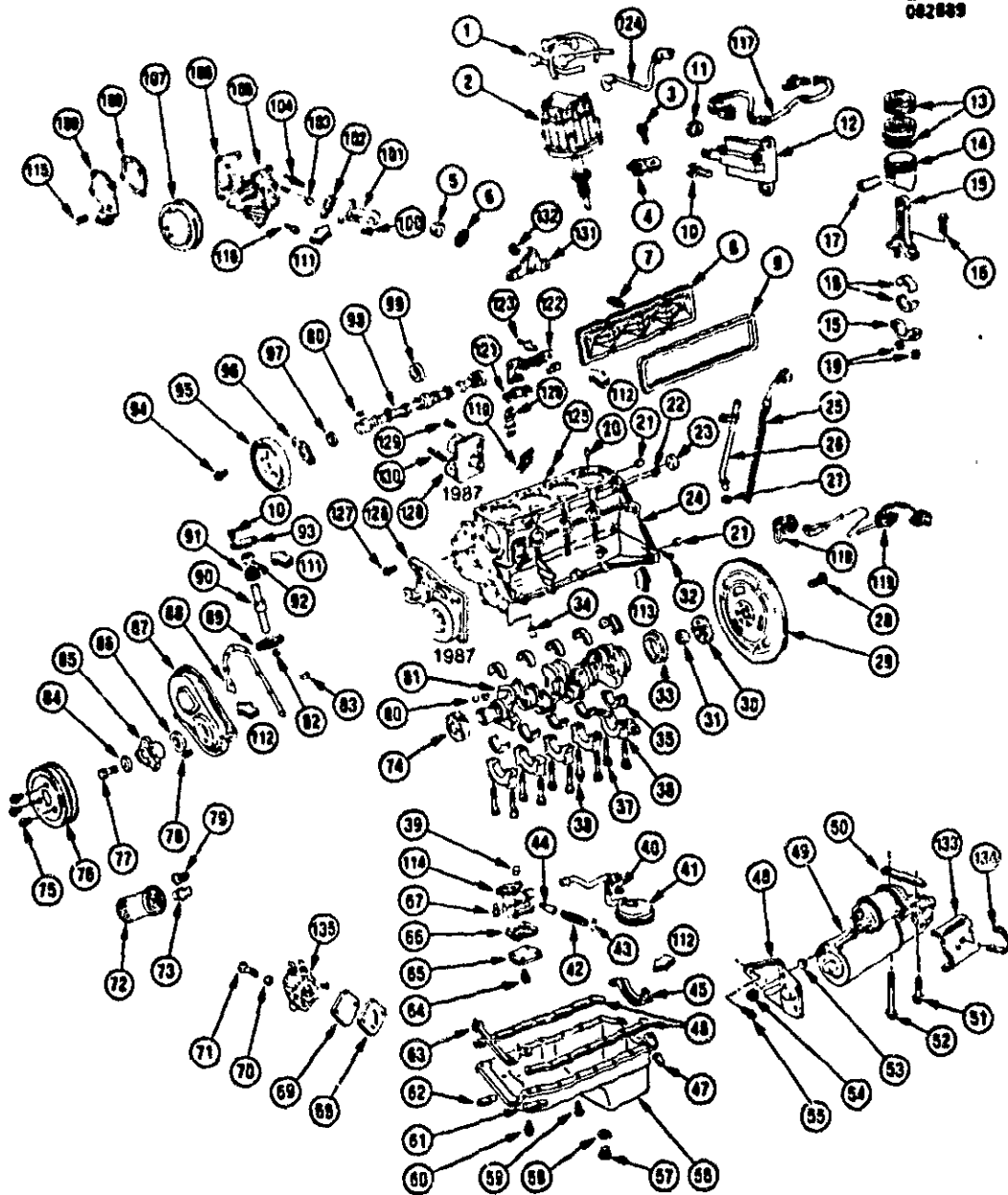

GM00-0622

1984-1987 P ENGINE ASM-2.5L I.4 PART 1 (LR8/2.5R)

1.	F15	2.240	WIRE, SPARK PLUG (SEE CAT CHART)	12043609
2.		2.361	DISTRIBUTOR, IGNITION (1982-86K*1)	
3.		8.900	BOLT, HEX (M8X1 25X25) 9 8 POR	
4.	G2	2.363	CLAMP, DIST HOLD DOWN	10023324
5.		8.917	NUT, HEX W/CON (M8X1) 9 PEOR	
6.		N.S.	RETAINER, HARN TO LFTR CVR	
7.	D9	0.446	STUD, W/SEAL. CVR (1984)	10004722
	D9	0.429	STUD, W/WA. PUSH RD CVR (1985-88)	10044611
	D9	0.439	COVER, PUSH ROD	10043084
	D9	0.443	GASKET, PUSH ROD COVER	10021542

10.		8.900	BOLT, HEX (M8X1 25X16)	
11.		8.915	NUT, HEX (M8X1 25X7 8)	
12.	F14	2.170	COIL, IGN (1984)	1116455
	F14	2.170	COIL,IGN(1985-86)	1115315
	F14	2.170	COIL,IGN(1987-88)	10497771
	F14	2.183	BRACKET,IGN COIL(1984)	1984415
	F14	2.183	BRACKET,IGN COIL(TOP)(1985)	1988368
	F14	2.183	BRACKET,IGN COIL(BOTTOM)(1985)	1988389
13.	D9	0.643	RING KIT, PISTON	10037199
14.	D9	0.629	PISTON, W/PIN ENGINE	10027317
15.	D9	0.603	ROD, CONN	10042989
16.	D9	0.623	BOLT, CONN ROD (11/32-24X2)	10000569
17.	D9	0.636	PIN, PISTON (1984-85)	500011
18.	D9	0.616	BEARING KIT, CONN ROD	12329992
19.	D9	0.626	NUT, CONN ROD	527599
20.	D9	0.293	PIN, CYL HD DWL (5/16X11/16)	522780
21.	D9	0.686	PIN, TRANS LINE UP	477231
22.		8.971	PLUG, RR OIL GALLEY SQ SOC (3/8X18)(1 073)	
23.	D9	0.553	PLUG, CM/SHF RR BRG	10038984
24.	D9	0.033	BLOCK, ENG FITTED	10042846
	D9	0.033	ENGINE, PARTIAL(1984)	10117784
	D9	0.033	ENGINE,PARTIAL (NOTE 5.6 7 10 15)(1985-86)	10159544
	D9	0.033	ENGINE,PARTIAL(1987)	10159543
25.	E14	1.516	INDICATOR, OIL LEVEL	10184917
26.	E14	1.516	TUBE, OIL LEVEL IND	10028739
27.	E14	1.516	SEAL, OIL LEVEL IND TUBE	526895
28.	D9	0.669	BOLT, FLYWHL TO CR/SHF	10004357
29.	D9	0.666	FLYWHEEL, CR/SHF	10044408
30.	D9	0.666	SPACER, FLYWHL TO CR/SHF	10005655
31.	D9	0.649	INSERT, CR/SHF	10018699
32.		8.900	BOLT, HEX (M12X1 75X20) 9 8 ZC	
33.	D9	0.137	SEAL, CR/SHF RR OIL	10036788
34.	E14	1.639	BEARING, PUMP SHAFT LWR	10004842
35.	D9	0.098	BEARING KIT, CR/SHF RR	10046335
36.		N.S.	CAP, BEARING (PART OF 24)	
37.	D9	0.056	BOLT, BEARING CAP (9)	10031654
38.	D9	0.056	STUD, BEARING CAP (1)	10101701
39.	E14	1.531	PLUG, OIL PRESS REG HOLE	3930824
40.		8.917	NUT, HEX PREV TO (M10X1 5) 10 CAD	
41.	E14	1.652	PUMP, W/SCREEN OIL	10009208
42.	E14	1.609	SPRING, OIL PRESS REG VALVE	3814903
43.	E14	1.609	PIN, OIL PRESS REG VLV SPR STOP	838839
44.	E14	1.609	VALVE, OIL PRESS REG	3829433
45.	E13	1.429	SEAL, OIL PAN RR (ALSO PART OF 46)(1982)	10021323
46.	E13	1.429	GASKET KIT, OIL PAN (INCL 45 63)(1982)	10021749
47.		N.S.	REINFORCEMENT, OIL PAN-LH (1982)	
48.	F13	2.042	BRACKET, START MTR	10031874
49.	F7	2.041	MOTOR, STAPT(1982-83)	1109562
	F7	2.041	MOTOR,STARTER(1984-87)	10455023
50.	F13	2.042	SHIM, START MTR	10008053
51.	F13	2.042	BOLT, START MTR (M10X1 5X46)	14001842
52.	F13	2.042	BOLT, START MTR (M10X1 5X114,	14001841
53.		8.929	WASHER,FL 7/32X1/2X5/8 1050 CAD HARD(AR)	2077521
54.		8.921	NUT,STAMPED/DF/W-SEALER #10-24 ZC(AR)	
55.		8.900	BOLT,HEX M10X1 5X20 10 9 POR(AR)	
56.	E13	1.426	PAN, OIL	10044683
57.	E13	1.453	PLUG, OIL DRAIN (M12X1 75)	10017615
58.	E14	1.456	GASKET, DRN PLUG(1982-84)	14090906
	E14	1.456	GASKET,OIL PAN DRN BOLT(1985-87)	10017614
59.		8.900	BOLT,HEX M6X1X14 10 9 PC(AR)	11503886
		8.900	BOLT,HFH M6X1X13 9 8 POR W-ADH 14 2 OOTHD LGTH 1"OO(AR)	14063759
60.		8.900	BOLT,HEX 1/4-20X3-4 300M PC(AR)	
		8.900	BOLT,1/4-20X5/8 HF, 280M ZP(AR)	
61.		N.S.	REINFORCEMENT, OIL PAN LH (1982)	
62.		N.S.	REINFORCEMENT, OIL PAN-RH (1982)	
63.	E13	1.429	SEAL, OIL PAN FRT (ALSO PART 46)(1982)	3923440
64.		8.900	BOLT,HEX M8X1 25X20 10 9 PZOR DiM A 17MM(AR)	11508687
65.	E14	1.723	COVER, OIL PUMP	3792507
66.	E14	1.724	GASKET, OIL PUMP COVER	3789970
67.		8.900	BOLT,HEX M8X1 25X20 10 9 PZOR DiM A 17MM(AR)	
68.		3.904	GASKET, FUEL PUMP	10114141
69.		3.901	COVER, FUEL PUMP OPG(1982 83)	10022599
70.		8.929	WASHER,FLAT 5/16X5/8X1 16 ZP HARD(AR)	2438182
71.		8.900	BOLT,HEX M8X1 25X30 10 9 PZOR(AR)	11508353
72.	E16	1.836	FILTER, OIL(1982 84)	25010908

72.	E16	1.836	FILTER,OIL(PF47X1985-87)	25010792
73.	E16	1.855	CONNECTOR, OIL FILTER	10004841
74.	D9	0.728	GEAR, CR/SHF	10028052
75.	D9	0.659	BOLT, CR/SHF PULLEY (1 079)	10042885
76.	D9	0.659	PULLEY, CR/SHF(1987)	10101389
	D9	0.659	PULLEY,CR/SHF(2 GROOVE.173MMXSK1984-87)	10021360
77.		8.900	BOLT,HEX M16X2X45 10 9 PC(AR)	
78.		8.900	BOLT,HFH,M6X1X13.9 8 POR.12.8 OD(AR)	
79.	E16	1.937	VALVE, OIL FILTER BY PASS	25010497
80.	D9	0.738	KEY, CM/SHF (0.662)	10028208
	D9	0.682	KEY, CR/SHF PUL HUB	10029208
	D9	0.729	KEY, CR/SHF (0.662)	10029208
81.	D9	0.648	CRANKSHAFT, ENGINE	10044541
82.		8.970	PLUG, FRT OIL GALLEY (587 DIA)	
83.	D9	0.748	NOZZLE, TIMING GEAR OIL	3875950
84.	D9	0.682	WASHER, HUB TO CR/SHF	10042038
85.	D9	0.659	HUB, CR/SHF PULLEY	10028930
86.	D9	0.213	SEAL, CR/SHF FRT OIL	10038285
87.	D9	0.208	COVER, TIMING GR	10044603
88.	D9	0.207	GASKET, FRT CVR TO BLK	10007042
89.	E14	1.724	GASKET,OIL PUMP CVR	3789970
90.	E14	1.639	SHAFT, OIL PUMP DRIVE UPPER	1977131
91.	E14	1.639	GEAR, UPR OIL DRIVE SHAFT (2 374)	1982052
		8.939	PIN,SPR COILED 3/16X3/4 PL(AR)	9422127
92.	E14	1.639	BEARING, PUMP UPR SHAFT UPR	10008555
93.	E14	1.723	PLATE, DRIVE SHAFT COVER	10031030
94.		8.900	BOLT,HEX M6X1X14 10.9 PC(AR)	
95.	D9	0.736	GEAR, CM/SHF	10101790
96.		N.S.	BEARING KIT, CM/SHF THRUST (INCL 97)	
97.	D9	0.738	RING, GR SPACING (ALSO PART OF 96)	548831
98.	D9	0.519	CAMSHAFT, ENGINE	10029787
99.	D9	0.639	BEARING, CM/SHF	14002525
100.		8.977	SCREW, HWH TAP (M8X1 25X25) POR	
101.	E9	1.073	INLET, WAT PUMP(1984-86)	10037949
	E9	1.073	INLET,W/PUMPI(1987)	10042097
102.	E9	1.079	GASKET, PUMP INLET	10124640
103.		8.900	BOLT,HEX M10X1 5X110.26 THD.PS. 10 9(AR)	
104.	E12	1.252	STUD, PUMP TO BLK	15598518
105.	E9	1.069	BODY, CLNT PUMP	10039422
	E9	1.069	HOUSING, PUMP BRG	10042972
106.	E9	1.079	GASKET, CLNT PUMP	10101878
107.	E7	1.082	PULLEY, CLNT PUMP(1984-86)	10004815
	E7	1.082	PULLEY,CLNT PUMPI(WWFX1987)	10041247
108.	D9	0.207	GASKET, FRT CVR PLATE (1982-84)	10007042
109.	D9	0.219	INDICATOR, W/PLATE TIMING (1982-86)	10031935
110.	E15	1.800	SENDER, OIL PRESS & F/PUMP (W/GAX1982-83)	10045776
	E15	1.800	SWITCH KIT, OIL PRESS (EXC GA)	25038378
	N16	3.910	SENSOR, F/PMP SW & ENG OIL PRESS (W/GAX1 800) (1983-87)	10045775
111.		8.900	SEALANT, RTV (3 OZ)	
112.		8.800	SEALANT, SILICONE	
113.		8.800	SEALANT, GSKT ELIMINATOR-LOCTITE	
114.	E14	1.652	PUMP, W/SCREEN OIL	10008206
115.	E14	1.857	STUD, HEX HD (M8X1 25X16) 9 8 POR (0 206)	1640161
	D9	0.219	STUD, T/POINTER & PLT (2 251X1985-86X"P")	25527241
116.		8.900	BOLT, HEX (M10X1 5X25) 10 9 POR	
117.	F15	2.240	WIRE, DIST COIL LEAD (CLIP ENDSX1985-86)	12039177
118.	E9	1.152	HEATER, ENG BLOCK	52351023
119.	E9	1.152	CORD, ENG BLOCK HTR	52354643
120.	D9	0.459	LIFTER, VLV ROLLER	5233745
121.	D9	0.480	GUIDE, VLV LIFTER	10028057
122.	D9	0.480	RETAINER, VLV LIFTER GUIDE	10028056
123.	D9	0.429	STUD, W/WA PUSH ROD	10044611
124.	F15	2.240	WIRE, COIL (1984-86)	12038972
125.		8.970	PLUG, WAT JKT SI (41 5MM DIAM)	10000482
126.	E7	1.080	TENSIONER, DR BELT (1987)	10088899
127.		8.900	BOLT, HWH (M10X1 5X35) 10 9 POR (1987)	14058165
128.		N.S.	COIL, W MODULE IGN (1987X*1)	
129.		8.900	BOLT, HFH (M8X1 25X30) POR (1987)	11509348
130.	F14	2.183	STUD, IGN COIL & MODL E (1987)	10085558
131.	N9	3.162	BRACKET, FUEL FEED & RTN PIPE CLIP	10042136
132.		8.917	NUT, HFH (M6X1X6 5) 9 ZOR	11503747
133.	F13	2.642	SHELD, START MTR (PX1984-87)	10035978
134.	F13	2.642	CLIP, START MTR SHLD (PX1984-87)	10038058
135.		3.280	PUMP, VAC (1982-83)	5838846

NOTE 1. SEE RESPECTIVE GROUP FOR DETAILED ILLUSTRATED VIEW

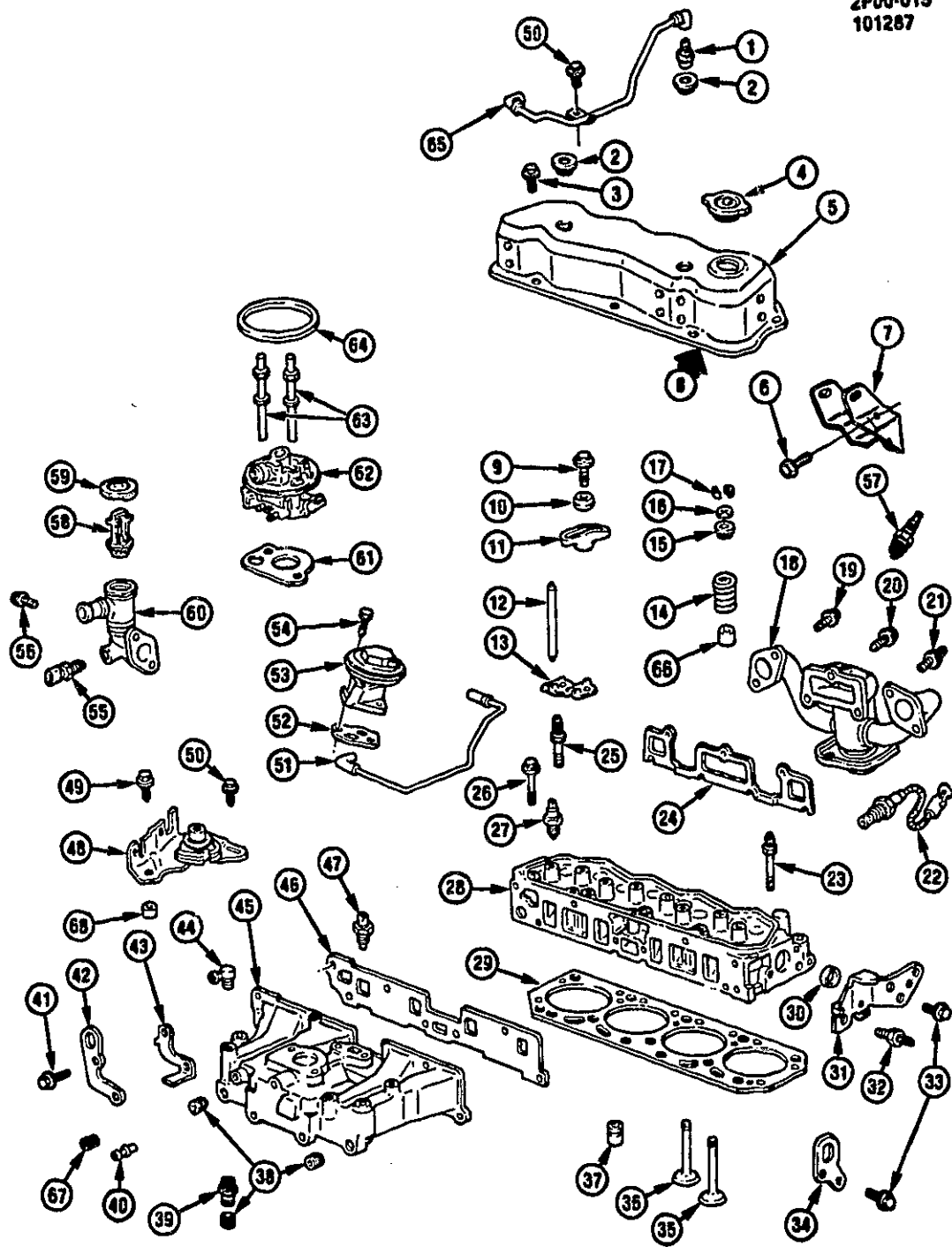

1987-1988 P ENGINE ASM-2.5L L4 PART 2 (LR8/2.5R)

1.	E15	1.745	VALVE, CR/CASE VENT (CV895C)	25095452
2.	E15	1.745	GROMMET, CR/CASE VENT TO RKR ARM CVR	10037287
3.		8.900	BOLT, HFH. 6X1X14.150D. FULL THD. 9 8. POR. HRD PT (AR)	10044260
4.	E15	1.758	CAP, OIL FIL (FC104)	10044670
5.	D9	0.386	COVER, W/BLF VLV RKR ARM	10044306
6.	F23	2.277	SCREW, HEX (M10X1 5)	10008894
7.	D9	0.029	BRACKET, ENG MT STRUT	10048480
8.		8.800	SEALANT, SLC RTV	1052915
9.	D9	0.429	BOLT, VLV RKR ARM BALL	10040236
10.	D9	0.429	BALL, RKR ARM	10008244
11.	D9	0.333	ARM, W/BALL VLV RKR	10121095
12.	D9	0.426	ROD, VLV LIFTER PUSH	10040235
13.	D9	0.439	GUIDE, VLV PUSH ROD	10012915
14.	D9	0.303	SPRING, VLV	10040232
15.	D9	0.309	CAP, VLV SPR	10040230
16.	D9	0.308	SEAL, INT VLV STEM OIL(*1)	10042875
17.	D9	0.310	KEY, VLV STEM	380505
18.	N13	3.601	MANIFOLD, EXH (1987)	10044374
	N13	3.601	MANIFOLD, EXH (1988)	10086673
19.	N10	3.275	BOLT, EXH MANIF TO CYL HD (POS 1.2.6.7)	10026336
20.		8.900	BOLT, HWH (M10X1 5X25) 10 9 PHOS (POS 4.5 1987) BOLT HWH (M10X1 5X25) 10 9 PHOS (POS 3.4.5 1988)	11502788
21.	N10	3.275	BOLT, EXH MANIF TO CYL HD (POS 3 1987)(1 252)	15598518
22.	N15	3.682	SENSOR, EXH OXYGEN (1 WIRE)(1987)	8990741
	N15	3.682	SENSOR, EXH OXYGEN (1988)	25105107
23.	D9	0.293	STUD, HEX DBL END (11X1 5X100 & 10X1 5X18) STL 11 9	12338010
24.	N10	3.270	GASKET, EXH MANIF(*1)	10086630
25.	D9	0.293	STUD, CYL HD (M11X1 5X75/M10X1 5X18)	10044568
26.	D9	0.293	BOLT, CYL HD (M11X1 5X100) PL	10044566
27.	E9	1.150	SENSOR, CLNT TEMP GA/HOT LIGHT	25038809
28.	D9	0.269	HEAD, CYL	10049100
29.	D9	0.289	GASKET, CYL HD(*1)	10101784
30.		8.970	PLUG, WATER JACKET-SIDE DIAM 41 5MM (AR)	10000462
31.	N9	3.162	BRACKET, FUEL FEED & RTN HOSE CLIP	10042093
32.	D9	0.004	STUD, ACCEL CONT CBL RET BRKT	25517778
33.		8.900	BOLT, HFH M10X1 5X20 9 8 PZOR (AR)	11508202
34.	D9	0.004	BRACKET, ENG LIFT FRT	10004894
35.	D9	0.298	VALVE, INT	10040226
36.	D9	0.287	VALVE, EXH	10044612
37.	D9	0.459	LIFTER, VLV (RLR)	5233745
38.		8.971	PLUG (AR)	25522486
39.	N25	8.666	CONTROL, HTR WTR HOSE	10042695
40.		N.S.	NIPPLE, INT MANIF (1988)	
41.		8.900	BOLT, HEX M8X1 25X30 10 9 PZOR (AR)	11508353
42.	D9	0.004	BRACKET, ENG LIFT RR	10044236
43.	F17	2.251	BRACKET, IGN CBL HARN	10044431
44.		N.S.	FITTING, P B (1 PORT VAC)	
45.	N10	3.265	MANIFOLD, INT	10124608
46.	N10	3.270	GASKET, INL MANIF(*1)	10041986
47.	N11	3.415	SENSOR, MANIF AIR TEMP (1987)	25036751
	N15	3.682	SENSOR, MANIF AIR TEMP (1988)	25037225
48.		N.S.	BRACKET & PULLEY, THROT MOD SYS (SERV BY)	
	N12	3.452	BRACKET, THROT MOD SYS	10041784
	N12	3.454	PULLEY, THROT IDL	10041788
	N12	3.459	SPRING, THROT IDL	10044141
	N16	3.880	PULLEY, CR/CONT SERVO CBL	10041798
	N16	3.880	SPRING, CR/CONT SERVO CBL PUL	10041799
	N12	3.469	CLIP, THROT PUL MOD	10029893
	N16	3.880	WASHER, CR/CONT SERVO CBL PUL	10041780
49.		8.900	BOLT, HFH M8X1 25X35 10 9 PZOR (AR)	11507034
50.		8.900	BOLT, HFH. M8X1 25X20. 10 9. POR (AR)	11514343
51.	N16	3.075	TUBE, EGR VLV VAC	10044339
52.	N15	3.080	GASKET, EGR VLV TO PLNM	10009586
53.	N13	3.070	VALVE, EGR	17110478
54.		8.900	BOLT, HFH M8X1 25X25 9 8 POR (400)(AR)	11508106
55.	N15	3.682	SENSOR, ECM (CLNT TEMP) (1 150)	25036979
56.		8.900	BOLT, HFH M8X1 25X16 17 6-OD 9 8 PZOR (AR)	11507022
57.	F17	2.270	PLUG, SPARK (AC R 43TS6)	5614046
58.	E12	1.246	THERMOSTAT, ENG CLNT OTLT (195 DEG)	3059793
59.	E12	1.251	CAP, THERM HSG	6410941
60.	E12	1.251	HOUSING, THERM	10038440
61.	N16	3.726	GASKET, TBI	10086605
62.		N.S.	THROTTLE BODY INJ(*2)	17111908

63.	N11	3.288	STUD, TBI (MBX1 25X64) 9 8 POR	10044417
64.	N11	3.403	GASKET, A/CLNR	10042945
65.		N.S.	TUBE, CR/CASE VENT VLV	
66.	O9	0.308	SEAL, W/RET. INL VLV STEM (STD 003" O S)	460483
67.		N.S.	BOLT, CYL BLK DRN HOSE	
68.	N12	3.454	SPACER, THROT MOD SYST BRKT (1988)	10044708

NOTE 1 ALSO PART OF VALVE GRIND KIT - 0 289

NOTE 2 SEE CHART IN GROUP FOR USAGE

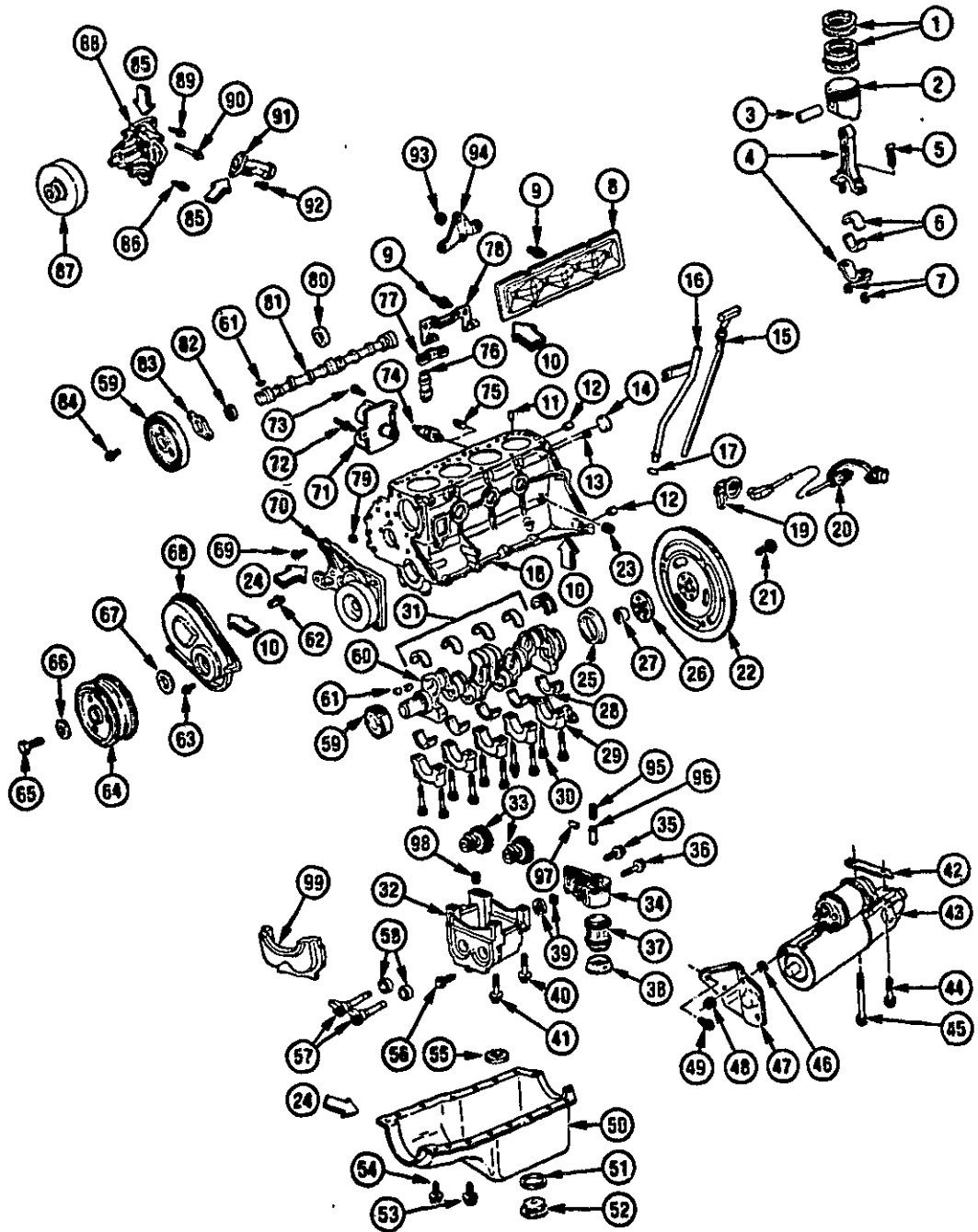

1988 P ENGINE ASM-2.5L L4 PART 1 (LR8/2.5R)

1.	D9	0.643	RING KIT, PSTN STD	10037199
2.	D9	0.629	PISTON, W/PIN (INCL 3)	10101711
3.		N.S.	PIN, PSTN (PART OF 2)	
4.	D9	0.603	ROD, CONN ROD	10042959
5.	D9	0.623	BOLT, CONN ROD (11/32X24X2 0) PHOS	10000569
6.	D9	0.616	BEARING KIT, CONN ROD STD	12329999
7.	D9	0.626	NUT, CONN ROD	527599
8.	D9	0.439	COVER, PUSH ROD	10043084
9.	D9	0.429	STUD, W/WA PUSH ROD	10044611
10.		8.600	SEALANT, LOCTITE GSKT MAKER (518)	1052942
11.	D9	0.293	PIN, CYL HD DWL (5/16X11/16)	522780
12.	D9	0.685	PIN, TRANS LINE UP	477231
13.		8.971	PLUG, CYL & CASE OIL GAL HOLE (1 073)	14090911
14.	D9	0.553	PLUG, CM/SHF RR BRG	10036984
15.	E14	1.516	INDICATOR, OIL LVL	10184924
16.	E14	1.516	TUBE, OIL LVL IND	10044310
17.	E14	1.516	SEAL, OIL LVL IND TUBE	10101844
18.	D9	0.033	ENGINE, PARTIAL (INCL 29)	10104495
19.	E9	1.152	HEATER, ENG BLK	52351033
20.	E9	1.152	CORD, ENG BLK HTR	25529223
21.	D9	0.669	BOLT, FLYWHL TO CR/SHF (W/A T)	10031828
	D9	0.669	BOLT, FLYWHL TO CR/SHF (W/M T)	10004357
22.	D9	0.666	FLYWHEEL, GR & RG (W/A T)	10044361
	D9	0.666	FLYWHEEL, GR & RG (W/M T)	10044408
23.		N.S.	BOLT, WAT DRN	
24.		8.800	SEALANT, SLC RTV	1052915
25.	D9	0.137	SEAL, CR/SHF RR OIL	10036788
26.	D9	0.666	SPACER, FLYWHL TO CR/SHF (W/A T)	10005655
27.	D9	0.649	INSERT, CR/SHF (W/A T)	10018599
	D9	0.649	INSERT, CR/SHF (W/M T)	10009785
28.	D9	0.098	BEARING KIT, CR/SHF RR	10046335
29.		N.S.	CAP, BRG (PART OF 18)	
30.	D9	0.066	BOLT, CR/SHF BRG CAP (M11X1.5X70) 10.9 PL	10031854
31.	D9	0.098	BEARING KIT, CR/SHF (NO 1,2,3,4)	18012433
32.	D9	0.659	HOUSING, BAL (INCL 33,55,57,58)	10101422
33.		N.S.	GEAR, WT BAL (PART OF 32)	
34.	E14	1.723	COVER, O/PUMP (INCL 95,96)	10038405
35.		8.977	BOLT, HFH (M6X1X25) PHOS	11509245
36.	E14	1.723	SCREW, O/PUMP	11509547
37.	E16	1.836	FILTER, INT FLTR OIL (PF1072)	25012305
38.	E13	1.426	RESTRICTOR, OIL PAN DRN	10043085
39.	E14	1.639	GEAR, O/PUMP	10038402
40.	D9	0.662	BOLT, BAL W/WA (M8X1.25X80) 10.9 PHOS	10044303
41.	D9	0.662	BOLT, BAL HFH W/WA (M8X1.25X100)	10044304
42.	F13	2.042	SHIM, START MTR (NOT REQ)	
43.	F7	2.041	MOTOR, START (CMPTS SERV)* 1.2)	10465023
44.	F13	2.042	BOLT, START MTR (M10X1.14)(INBD HOLE)	14001841
45.	F13	2.042	BOLT, START MTR (M10X1.14)(OUTBD HOLE)	14001842
46.		8.929	WASHER, FL (7/32X1/2X5/8) CAD	2077521
47.	F13	2.042	BRACKET, START MTR	10031874
48.		8.921	NUT, STMP/DF/W/SEAL (10-24) ZN	9426926
49.		8.900	BOLT, HEX (M10X1 5X20) 10.9 POR	11504595
50.	E13	1.426	PAN, OIL	10044674
51.	E14	1.456	GASKET, OIL PAN DRN & FLTR	10038854
52.	E13	1.453	PLUG, OIL PAN DRN	10044483
53.		8.900	BOLT, HEX (M6X1X14) 10.9 PHOS	11503885
54.		8.900	BOLT, HEX (1/4-20X3/4) 300M PHOS	9425113
55.		N.S.	SCREEN, BAL & PUMP (PART OF 32)	
56.		8.977	SCREW, HWH (M6X1X13) PHOS	
57.		N.S.	SHAFT, BAL & PUMP (PART OF 32)	
58.		N.S.	BUSHING, BAL & PUMP (PART OF 32)	
59.	D9	0.736	GEAR UNIT, CM/SHF & CR/SHF GR	10101790
60.	D9	0.646	CRANKSHAFT	10044541
61.	D9	0.729	KEY, CR/SHF GR (0 662)	10029208
62.	D9	0.748	NOZZLE, TIMING GR OIL	3875950
63.		8.900	BOLT, HFH (M6X1X13) 9 8 POR	10042901
64.	D9	0.659	PULLEY, CR/SHF	10101389
65.		8.900	BOLT, HEX (M16X2X45) 10.9 PS	11509460
66.	D9	0.662	WASHER, HARM BAL TO CR/SHF	10042038
67.	D9	0.213	SEAL, TIMING GR CVR TO CR/SHF	10036286
68.	D9	0.208	COVER, TIMING GR	10044603
69.		8.900	BOLT, HWH (M10X1 5X35) 10.9 PZOR	14056165
70.	E7	1.060	TENSIONER, DR BELT	10041248

71.		N.S.	COIL, W/MOD IGN (CMPTS SERV#*1)	10065558
72.	F14	2.183	STUD, IGN COIL & MOD (3 275)	11509348
73.		8.900	BOLT, HFH (M8X1 25X30) 10 9 POR	1643532
74.	E15	1.800	SENSOR, F/PUMP SW & O/PRESS (W/GA)	10000482
75.		8.970	PLUG, WAT JKT (41 5MM)	5233746
76.	D9	0.459	LIFTER, RLR	10028057
77.	D9	0.480	GUIDE, VLV LFTR	10028058
78.	D9	0.480	RETAINER, VLV LFTR GDE	3835677
79.		8.970	PLUG, SPL FRT OIL GAL	14002525
80.	D9	0.539	BEARING, CM/SHF	10029787
81.	D9	0.519	CAMSHAFT	549831
82.	D9	0.738	RING, CM/SHF GR SPACING	
83.		N.S.	BEARING, CM/SHF THR	
84.		8.900	BOLT, HEX (M6X1X14) 10 9 PHOS	11503885
85.		8.800	SEALANT, RTV	1052751
86.		8.900	BOLT, HFH (M10X1 5X25) 9 8 PZOR	14083755
87.	E7	1.082	PULLEY, CLNT PUMP	10041247
88.	E9	1.089	PUMP, CLNT	10159528
89.		8.900	BOLT, HEX FLG HD (M10X1 5X30) 9 8 PZOR	11507023
90.		8.900	BOLT, W/PUMP (1 079)	11509072
91.	E9	1.073	INLET, CLNT PUMP	10042097
92.		8.977	SCREW, HWH (M8X1 25X30) POR	15807203
93.		8.917	NUT, HEX W/CON WA (M6X1) 19 PEOR	11508277
94.	N9	3.182	BRACKET, F/FEED & RTN PIPE CLIP	10042093
95.	E14	1.609	SPRING, O/PRESS REG VLV (PART OF 34)	10044435
96.	E14	1.609	VALVE, O/PRESS REG (PART OF 34)(INCL 97)	10038408
97.		8.939	PIN, SPR (PART OF 96)	9440899
98.	D9	0.652	PIN, BAL HSG DWL	10042916
99.	D9	0.659	BAFFLE, BAL WT	10044489

NOTE 1 SEE RESPECTIVE GROUP FOR DETAILED ILLUSTRATED VIEW

NOTE 2 SEE CHART IN GROUP FOR USAGE

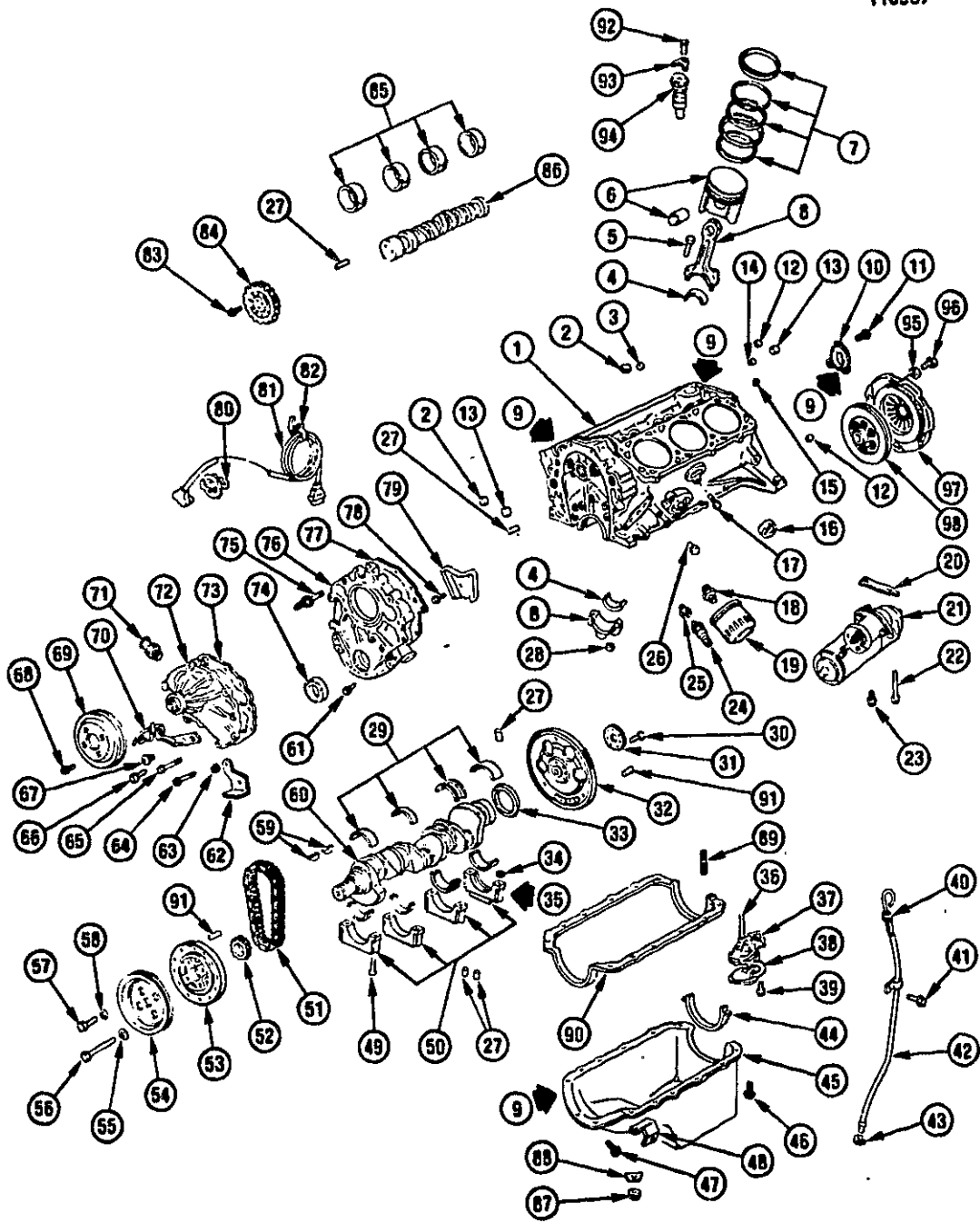

1985-1988 P ENGINE ASM-2.8L V6 PART 1 (L44/2.8-9)

1.	D9	0.033	ENGINE, PARTIAL (1985-86)	10159544
	D9	0.033	ENGINE, PARTIAL (1987)	10159543
	D9	0.033	ENGINE, PARTIAL (1988)	12508003
2.		8.971	PLUG,AUTO HEX SOC DRN 250-18 ZN(AR)	
3.		8.971	PLUG,CUP 3/4 PL(AR)	9421749
4.	D9	0.616	BEARING KIT, CONN ROD (STD)	18098492
5.	D9	0.623	BOLT, CONN ROD	488337
6.	D9	0.629	PISTON, W/PIN	14092910
7.	D9	0.643	RING KIT, PISTON	14089059
8.	D9	0.603	ROD, CONNECTING	10078995
9.		8.800	SEALER,SILICONE(RTV T-200)(300 ML)(AR)	
10.	D9	0.553	COVER, CM/SHF RR	476544
	D9	0.553	GASKET, CM/SHF HSG RR CVR	10085415
11.		8.900	BOLT,HEX W/CON WA M6X1X15 9.8 PZOR 12.5-OD FULL THD(AR)	8839743
12.		8.971	PLUG,HEX SOC,250-18,69 LNG.PC,DOG PT(AR)	12338136
13.		8.971	PLUG,AUTO DRAIN,INT SQ DR,3/8-18X.42 PEOR STL(AR)	14090911
14.	D9	0.685	PIN, TRANS LINE UP CLU HSG	12338087
15.	D9	0.293	PIN, CYL HD DOWEL	14024244
16.	D9	0.034	PLUG, WAT JACKET HOLE (34.3X13)	360571
17.		8.971	PLUG,HEX,1/4-18X0.56,STEEL,PC(AR)	3889330
18.	E16	1.855	CONNECTOR, OIL FILTER	488383
19.	E16	1.836	FILTER, OIL (PF47)(1985-87)	25010792
	E16	1.836	FILTER, OIL (PF47)(1988)	25010908
20.	F13	2.042	SHIM, START MTR (24.4X106.7X0.38)	10088053
21.	F7	2.041	MOTOR, STARTER	10465023
22.	F13	2.042	BOLT, START MTR INBD HOLE (M10X114)	14001841
23.	F13	2.042	BOLT, START MTR OUTBD HOLE (M10X46)	14001842
24.	E15	1.650	SENSOR, F/PUMP SW & ENG OIL PRESS(1985-87)	10045775
	E15	1.600	SENSOR, F/PUMP SW & ENG OIL PRESS (1988)	10096168
25.		N.S.	FITTING, OIL PRESS SWITCH	
26.	E16	1.837	VALVE, OIL FILTER BY PASS	25010497
27.		8.939	PIN, M6X16 STL PL(AR)	11503504
28.	D9	0.626	NUT, CONN ROD	361970
29.	D9	0.098	BEARING KIT, CRANKSHAFT	18012472
30.	D9	0.689	BOLT, FLYWHL-M.T. (M10X1X23)	476576
	D9	0.689	BOLT, FLYWHL (M10X1X18.5)(A.T)	477289
31.	D9	0.689	RETAINER, FLYWHL A.T.	477288
32.	D9	0.688	FLYWHEEL, CR/SHF	14018711
33.	D9	0.137	SEAL KIT, CR/SHF RR OIL	14085829
34.	D9	0.137	SEAL, RR BRG CAP O-RING	12338164
35.		8.800	SEALANT,LOCTITE(518)(GASKET MAKER (6ML)(AR)	
36.	E14	1.639	SHAFT, DISTR TO OIL PUMP INTER	477248
37.	E14	1.652	PUMP, OIL	10146802
38.	E14	1.658	SCREEN, OIL PUMP	14092908
39.		8.900	BOLT,HFH M10X1.5X50 10.9 POR(AR)	11508355
40.	E14	1.516	INDICATOR, OIL LEVEL	10070156
41.		8.977	SCREW,HWH TAP M6X1X13 PC(AR)	11504474
42.	E14	1.516	TUBE, ENG OIL LVL IND	10033826
43.	E14	1.516	SEAL, OIL LVL IND TUBE	10101844
44.	E13	1.429	SEAL, OIL PAN REAR (1985-86)	14077876
45.	E13	1.426	PAN, OIL	10131027
46.		8.900	BOLT,HEX W/CON WA M6X1X15 9.8 PZOR 12.5-OD FULL THD(AR)	8839743
47.	E13	1.428	BOLT, OIL PAN (M8X1 25X14)	14077877
48.		N.S.	CLIP, ENG & GEN WRG HARN	
49.	D9	0.056	BOLT, CR/SHF BRG CAP	476543
50.		N.S.	CAP, CR/SHF BRG (PART OF 1)	
51.	D9	0.724	CHAIN, CM/SHF TIMING	14102670
52.	D9	0.728	SPROCKET, CR/SHF	477283
53.	D9	0.659	DAMPER, CR/SHF	14102508
54.	D9	0.659	PULLEY, CR/SHF	10041616
55.		8.929	WASHER,SPECIAL 12.4X44.5X8 0 THK PC(AR)	14001829
56.	D9	0.659	BOLT, TORSIONAL DAMPER	14001828
57.		8.900	BOLT,HEX M10X1.5X25 10.9 POR(AR)	11504596
58.		8.931	WASHER,SPR LK 7/16 X 2b/32 X 7/64 ZOR(AR)	9439513
59.		8.980	KEY,WOODRUFF #9 .187X.750 PL(AR)	108751
60.	D9	0.646	CRANKSHAFT, ENG (1985-87)(1'2)	10048582
	D9	0.646	CRANKSHAFT, ENG (1988)	14085481
61.	D9	0.206	BOLT, CR/CASE (3.275)	14081015
62.	N9	3.163	SHIELD, F/PIPE (W/A.C)	10036499
63.		8.916	NUT,HEX M8X1 25X7.8 10 1040MPA PC(0349)(AR)	12337995
64.	D9	0.206	SCREW, CR/CASE	14092949
65.	D9	0.208	SCREW, CR/CASE	14092950

66.		8.900	BOLT ASM,HEX W/CON WA.M6X1X25.17 OD. FULL THD.AC PT.9 8.CD CHROMATE BLK(AR)	11509363
67.	D9	0.208	SCREW, TIMING POINTER (M6X1X10)(PART OF 76)	14003948
68.		8.900	BOLT,HFH MBX1 25X16 17 6-OD 9 8 PZOR(AR)	11507022
69.	E7	1.082	PULLEY, COOLANT PUMP	10032580
70.		N.S.	INDICATOR, TIMING (PART OF 76)	
71.	N25	8.888	NIPPLE, HTR HOSE (IN CLNT PUMP)(1985-86)	14085475
72.	E9	1.089	PUMP KIT, COOLANT	10174880
73.	E9	1.079	GASKET, COOLANT PUMP(*1)	10087564
74.	D9	0.213	SEAL, CR/SHF FRT OIL(*1)	10111769
75.	D9	0.208	STUD, CR/CASE	14100828
76.	D9	0.208	COVER, TIMING GEAR (INCL 67,70)	10039016
77.	D9	0.207	GASKET, CR/CASE FRT END CVR(*1)	10087561
78.		8.900	BOLT,HFH W/CON WA(M8X1.25X20)9 8 POR(AR)	11508017
79.	D9	0.724	DAMPER, TIMING CHAIN GUIDE	477264
80.	E9	1.152	HEATER, ENG BLOCK	52350510
81.	E9	1.152	CORD, ENG BLOCK HEATER	52353831
82.		8.985	RETAINER,PLASTIC 7" ADJUSTABLE STRAP(AR)	3816659
83.	D9	0.738	BOLT, CM/SHF SPKT	477280
84.	D9	0.738	SPROCKET, CM/SHF	14025558
85.	D9	0.839	BEARING, CM/SHF	14033120
86.	D9	0.519	CAMSHAFT, ENGINE	10118638
87.		8.917	NUT,HFH M6X1X6.5 ZOR 9(AR)	11503747
88.	E13	1.426	REINFORCEMENT, OIL PAN FRT (1987-88)	14089825
89.	E13	1.428	STUD, OIL PAN(M6X1X13/M6X1X21.5)(0.413)(1987-88)	14092908
90.	E13	1.429	GASKET, OIL PAN (1987-88)	14080535
91.		8.940	PIN,GROOVE/F/.312X.375 CZ(AR)	274584
92.		8.900	BOLT, HEX (M10X1.5X35) 10.9 PS	11513608
93.	G2	2.383	CLAMP, IGN TIMER DISTR	477217
94.	E14	1.839	DRIVE, OIL PUMP	1103670
95.		8.931	WASHER, SPR LK (5/16) PL	9439511
96.		8.900	BOLT, HEX (M8X1.25X22) 9.8 POR	11513805
97.	D9	0.859	COVER, W/PLT CLU PRESS (W/M.T.)	14106685
98.	D9	0.888	PLATE, CLU DRIVEN (W/M.T.)	14073764

NOTE 1. PART OF GASKET KIT, ENG FRT GROUP 0.207

NOTE 2- IF CRANKSHAFT HAS 1 KEYWAYS, USE 1 NO 14089209 KEY-TORSIONAL

2P00-008
082390

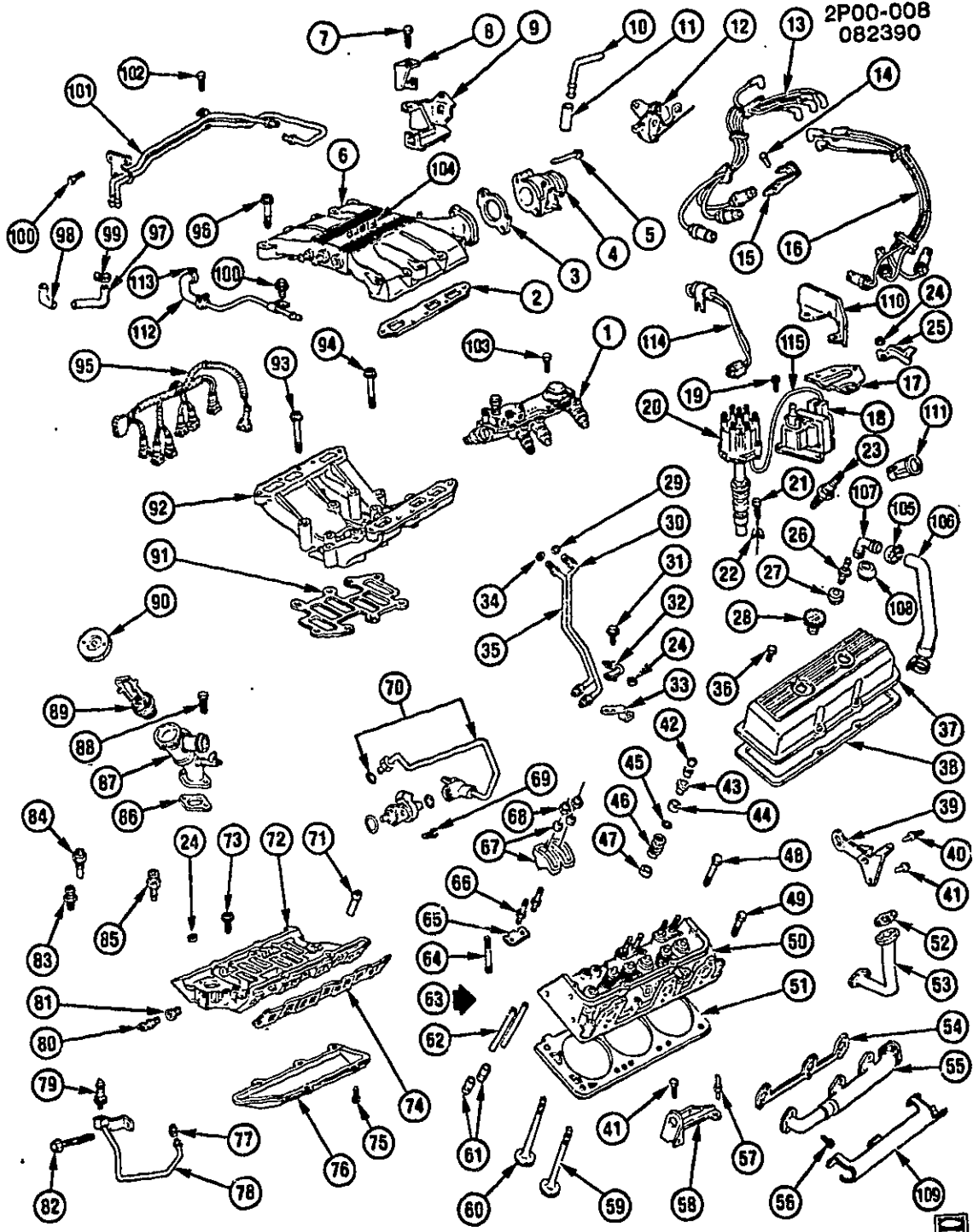

2P00-008

1985-1988 P ENGINE ASM-2.8L V6 PART 2 (L44/2.8-9)

1.	N.S.	RAIL ASM, FUEL (CPS)*1)	
2.	N10	3.270 GASKET KIT, INT MANIF PLENUM	10140830
3.	N11	3.335 GASKET, TBI	10034146
4.	N11	3.335 BODY, THROTTLE (CPS)*1)	
5.	N11	3.336 BOLT, TBI ATTACH (M8X1 25X55)	
6.	N10	3.265 PLENUM,INT MANIF (1985-86)	10033120
	N10	3.265 PLENUM, INT MANIF (1987-88)	10044861
7.	N12	3.454 BOLT, ACCEL CONT CBL BRKT TO MANIF (M8X1.25X20)	10035352
8.	F17	2.257 SUPPORT, SPARK PLUG WIRE (2.251)	10035907
9.	N12	3.454 BRACKET, ACCEL CONT CBL TV & CR/CONT	10036687
10.	N11	3.338 PIPE, THROT BODY IDLE AIR	10036778
11.	N11	3.338 HOSE, IDLE AIR CONN	10036758
12.	N12	3.454 LEVER, ACCEL CONT (W/A.T.)	10033141
	N12	3.454 LEVER,ACCEL CONT (W/M.T.)	10033145
13.	N.S.	HARNES, SPLG WIRE-RH (SEE CAT CHART)	
	F15	2.240 WIRE, COIL TO DIST/LEAD (8" LONG)	12042523
14.		8.977 SCREW,M4,2-1.41X25(AR)	
15.	F17	2.251 BRACKET, SPLG WIRE RR-RH	10035908
16.	N.S.	HARNES, SPLG WIRE-LH (SEE CAT CHART)	
17.	F14	2.183 SHIELD, IGN COIL HEAT (BTM)	
18.	F14	2.170 COIL, IGNITION	1115315
	F14	2.183 BRACKET, COIL (TOP)	1989322
	F14	2.183 BRACKET, COIL (BTM)	1988568
	F14	2.183 NUT, BRKT ATTCH TO COIL (8.915)	14081908
		8.900 BOLT,HWH M4X0.7X30 9.8 PC(AR)	
		8.977 SCREW,HWA TAP M7 9-2.12X20 PC(AR)	
20.		2.361 DISTRIBUTOR, IGNITION (CPS)*1)	
21.		8.900 BOLT,HEX M10X1.5X35 10.9 PC 31 THD LEN(AR)	
22.	G2	2.363 CLAMP, IGN TIMER DISTR	477217
23.	F17	2.270 PLUG, SPARK (R42TS)	5613324
24.		8.915 NUT,HEX M8X1.25X7.8 10 1040MPA PC(0349)(AR)	22521550
25.	F17	2.251 SUPPORT, SPLG WIRE FRT	10035908
26.	E15	1.745 VALVE, CR/CASE VENT (CV892C)	25043843
27.	E15	1.745 GROMMET, CR/CASE VENT VLV	10036261
28.	E15	1.758 CAP, OIL FILLER	10154789
29.	N9	3.163 SEAL, F/RTN PIPE (PART OF 30)	22516258
30.	N9	3.163 PIPE, F/RTN (INCL 29)	10048644
31.		8.977 SCREW,HWH TAP M6.3X1.81X13 13 OD PZOR(AR)	
32.	N9	3.162 CLIP, F/FEED & RTN PIPE	
33.	N9	3.162 BRACKET, F/FEED & RTN HOSE	10034785
34.	N9	3.163 SEAL, F/FEED PIPE (PART OF 35)	22514722
35.	N9	3.163 PIPE, F/FEED (INCL 34)	10048643
36.	D9	0.413 SCREW, RKR ARM CVR (SPL M6.0X1X25)	
37.	D9	0.386 COVER, VLV RKR ARM	10034704
38.	D9	0.423 GASKET, VLV RKR ARM CVR	10034707
39.	F17	2.251 BRACKET, IGN COIL & ENG LIFT RR (0.004)	10033898
40.	D9	0.004 STUD, ENG BRKT	
41.		8.900 BOLT,HEX FLG M10-1.5X20 9.8 PC(AR)	
42.	D9	0.310 KEY, VLV STEM	3947770
43.	D9	0.309 CAP, VLV SPRING	14004099
44.	D9	0.308 SHIELD, EXH VLV STEM OIL	10048657
45.	D9	0.308 SEAL, VLV STEM OIL	3835333
46.	D9	0.303 SPRING, W/DAMPER, VLV	14030029
47.	D9	0.308 SEAL, W/RET INL VLV STEM	460483
48.	D9	0.293 BOLT, CYL HD LG (0.056)	476543
49.	D9	0.293 BOLT, CYL HD SHT	476572
50.	D9	0.269 HEAD, CYLINDER	14054884
51.	D9	0.289 GASKET, CYL HEAD	14090561
52.	N14	3.671 GASKET, EGR VLV TUBE	10038300
53.	N15	3.680 TUBE, EGR VLV ADAPTER (1985-87)	10137017
	N15	3.680 TUBE, EGR VLV ADAPTER (1988)	10137021
54.	N10	3.270 GASKET, EXH MANIF	10051512
55.	N13	3.601 MANIFOLD, EXH-LH	10115725
	N13	3.601 MANIFOLD,EXH-RH	10115726
56.	N13	3.601 BOLT, EXH MANIF (M8X1.25X26)	11509843
57.	D9	0.004 STUD, ENG LIFT FRT BRKT (0.029)	14054414
58.	D9	0.004 BRACKET, ENG LIFT FRT	10137058
59.	D9	0.297 VALVE, EXH	14031332
60.	D9	0.286 VALVE, INT	14031328
61.	D9	0.459 LIFTER, VALVE (STD)	5234212
62.	D9	0.426 ROD, VLV PUSH	476525
63.		8.800 SEALER,SILICONE(RTV T-200)(300 ML)(AR)	
64.	D9	0.293 STUD, HD (M11X1.5X68/M8X1.25X15)	

65.	D9	0.439	GUIDE, PUSH ROD	478531
66.	D9	0.429	STUD, VLV RKR ARM BALL	478530
67.	D9	0.333	ARM, W/BALL VALVE RKR	10054525
68.	D9	0.429	NUT, VLV RKR ARM STUD	477212
69.		8.900	BOLT,HFH,M8X1.25X20.10.9,POR(AR)	11514343
70.		N.S.	INJECTOR ASM, COLD START FUEL (SERV BY)	
	N11	3.329	VALVE KIT, COLD START	17110860
	N11	3.329	TUBE KIT, COLD START	17112085
	N11	3.329	SEAL KIT,COLD START VLV O RING	17111954
71.	N10	3.265	TUBE, LWR INT MANIF (PART OF 72)	14078827
72.	N10	3.265	MANIFOLD, INTAKE LWR (INCL 71)	10057641
73.	N10	3.275	BOLT, INT MANIF (M8X1.25X63)(5)(1985-86)	14074395
	N10	3.275	BOLT,INT MANIF (M8X1.25X70)(5)(1987-88)	10082904
	N10	3.275	BOLT, INT MANIF (M8X1.25X53)(1)	14078864
74.		N.S.	GASKET, INT MANIF SIDE-RH("2)	
		N.S.	GASKET, INT MANIF SIDE-LH("2)	
75.	N12	3.417	STUD, INT MANIF OIL SPH GUARD	3959544
76.	N10	3.265	GUARD, INT MANIF OIL SPLASH	14078826
77.		N.S.	FITTING, OIL PRESS GA SEN PIPE W/A.C.	
78.	E15	1.803	PIPE, ENG OIL PRESS GA SEN	10035770
79.	E15	1.800	SENSOR, F/PUMP SW & ENG OIL PRESS	10045775
80.	N15	3.682	SENSOR, CLNT TEMP ECM (1.150)	25036979
81.	E9	1.150	BUSHING, CLNT TEMP GA SENSOR	10037037
82.		8.900	BOLT,HEX M10X1.5X60 35 THD 10 9 POR(AR)	11509265
83.	E6	1.055	SWITCH, FAN CONT (CLR BUTN TERM)	3046674
84.	N11	3.329	SWITCH, COLD START F/INJ	14084318
85.	N15	3.682	SENSOR, MANIF AIR TEMP (1985)	25036751
86.	E9	1.154	GASKET, CLNT OTLT	14079715
87.	E12	1.251	HOUSING, THERMO	10040122
88.		8.900	BOLT,HEX M8X1.25X20 10.9 PZOR DIM A- 17MM(AR)	11508687
89.	E12	1.246	THERMOSTAT, CLNT OTLT (195 DEG)	3059793
90.	E12	1.251	CAP, THERM HSG (TYPE-RC40)	6410941
91.	N10	3.270	GASKET, INT CTR MANIF("2)	10087601
92.	N10	3.265	MANIFOLD, INT CTR	14077854
93.	N10	3.275	BOLT, INT CTR MANIF	14078896
94.	N10	3.275	BOLT, MANIF (M8X1.25X70)(5)(7.518)	10082904
95.	G3	2.480	HARNES, F/INJ	12080977
96.	N10	3.275	BOLT, PLENUM TO MANIF (M8X1.25X55)(10)	
97.	N11	3.337	HOSE, THROT BODY HTR OTLT PIPE (CLNT)	10036781
98.	N11	3.337	HOSE, THROT BODY HTR INL PIPE (CLNT)	10036780
99.	E10	1.166	CLAMP, WORM TYPE (.56 TO 1.06 DIA)	22518665
100.		8.900	SCREW,HEX FLGD HD M6X1X20 9.8 OB(AR)	11503782
101.	E9	1.153	PIPE, THROT BODY CLNT SUPPLY & RTN	10040107
102.	N11	3.337	BOLT, SUPPLY & RTN PIPE (M6X1X25)	10035954
103.		8.900	BOLT,HFH M8X1.25X25 9.8 POR (400)(AR)	
104.	N10	3.265	DECAL, INT MANIF NA "FIERO" (1985-87)	10038240
105.		8.948	CLAMP,WORM GEAR 15.7 TO 31.8 ALL SS(AR)	12337891
106.		N.S.	HOSE, CR/CASE VENT TUBE TO CONN	
107.		N.S.	CONNECTOR, CR/CASE VENT TUBE TO RKR ARM	
108.	E15	1.745	GROMMET, CR/CASE VENT TUBE CONN TO RKR	10137083
109.	N25	8.849	SHIELD, HTR HOSE HT(AR)	10036661
110.	F14	2.183	SHIELD, IGN COIL HT SIDE	10040180
111.	F17	2.251	SHIELD, SPLG WIRE BOOT FRT & RR	12045651
112.	N20	4.846	TUBE, P/S BOOS (1987-88)	10044863
113.		8.948	CLAMP,WORM TYPE(1 1/16" TO 1 5/16")(AR)	1470030
114.	N26	9.750	FILTER, TACH SIGNAL	10040110
115.	F15	2.240	WIRE,COIL TO DIST/LEAD(8" LONG)	12042523

NOTE 1: SEE RESPECTIVE GROUP FOR DETAILED ILLUSTRATED VIEW.

NOTE 2: PART OF GASKET KIT, INLET MANIFOLD PLENUM- GROUP 3.270.

2P00-001
032588

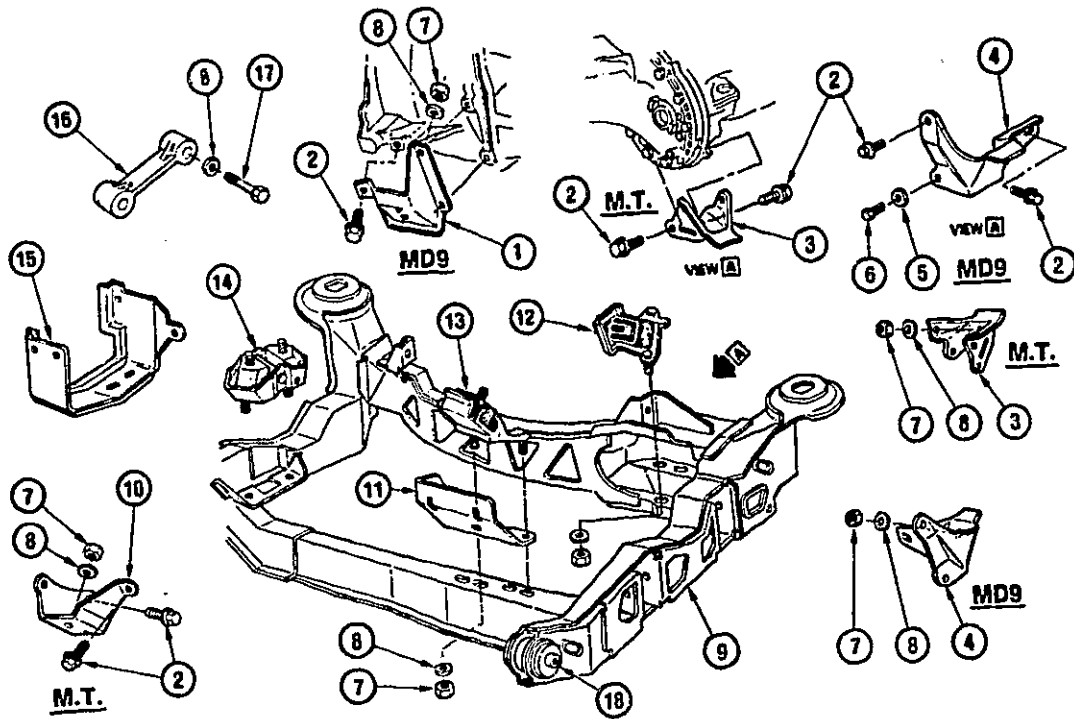

2P00-001

1984 P ENGINE & TRANSMISSION MOUNTING

1.	N17	4.081	BRACKET, TRANS MT (FRT)(MD9)	14036336
2.		8.900	BOLT, HFH (M10 X 1.5 X 25)	
3.	N17	4.081	BRACKET, TRANS MT RR (MY8, M19)	10026987
4.	N17	4.081	BRACKET, TRANS MT RR (MD9)	10093238
5.		8.929	WASHER, FL (M10 X 20 X 3)	
6.		8.900	BOLT, HEX (M10 X 1.5 X 45)	
7.		8.915	NUT, HEX PREV TQ (M10-1 5)	
8.		8.929	WASHER, FL (7/16")	
9.	D9	0.029	FRAME, DR TRAIN (EXC WS6)	10033671
10.	N17	4.081	BRACKET, TRANS MT FRT (2.5R)(M19)	14036337
11.	N17	4.083	SHIELD, TRANS MT FRT HEAT	10036596
12.	N17	4.081	MOUNT, TRANS RR	10046808
13.	N17	4.081	MOUNT, TRANS FRT (W/2.5L)	10046804
14.	D9	0.027	MOUNT, ENG (2.5R)	14073097
15.	D9	0.029	BRACKET, ENG MT (2.5R)	10023655
16.	D9	0.029	STRUT, ENG MT	10046816
17.		8.900	BOLT, HEX (M10 X 1.5 X 85)	

18. N26

9.023
8.900

BUSHING, FRT FRAME MTG
BOLT, HEX (M12X1 75X105)(10 9 PC)

10029077
11505584

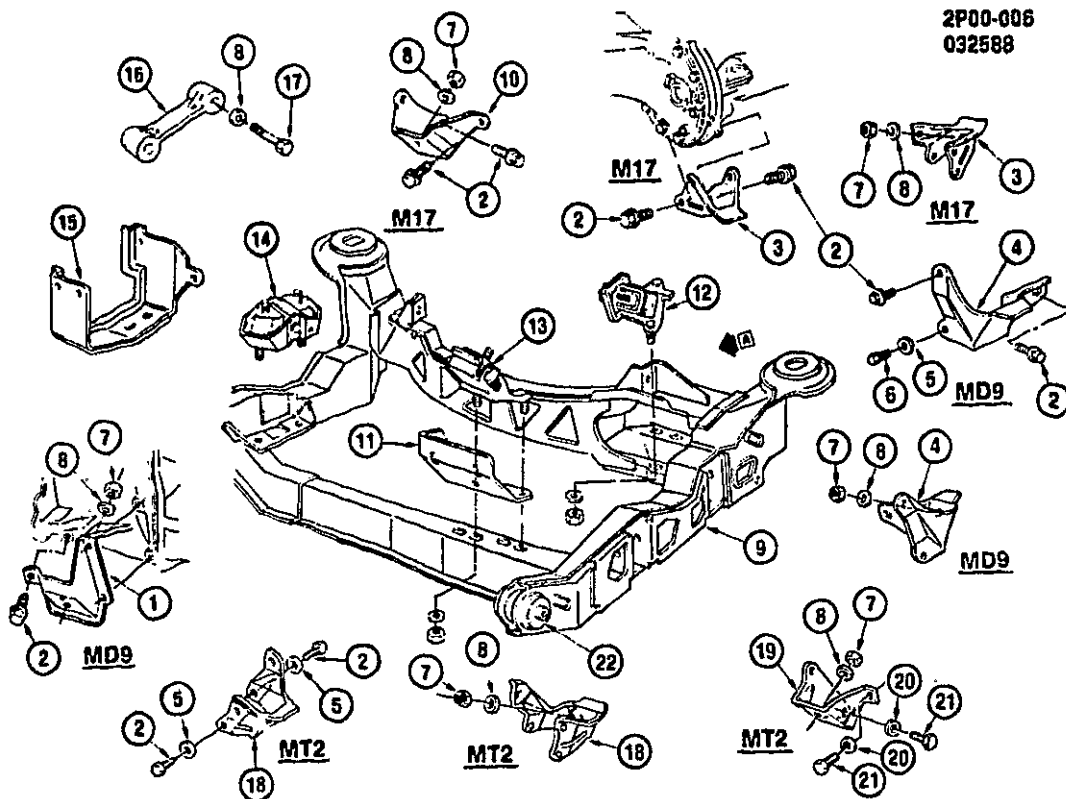

1985 P ENGINE & TRANSMISSION MOUNTING

1.	N17	4.081	BRACKET, TRANS MT(FRT)(MD9)	14036336
2.		8.900	BOLT, HFH (M10X1.5X25)	
3.	N17	4.081	BRACKET, TRANS MT(RR)(M17)	10026967
4.	N17	4.081	BRACKET, TRANS MT(RR)(MD9)	10093238
5.		8.929	WASHER, FL (M10X20X3)	
6.		8.900	BOLT, HEX (M10X1.5X45)	
7.		8.915	NUT, HEX PREV TO (M10-1.5)	
8.		8.929	WASHER, FL (7/16")	
9.	D9	0.029	FRAME, ENG (EXC H.D.SUSP F41,PERF PKG WS6)	10033671
	D9	0.029	FRAME, ENG-W/H.D.SUSP(F41),PERF PKG(WS6)	10033670
10.	N17	4.081	BRACKET, TRANS MT(FRT)(M17)	14038337
11.	N17	4.083	SHIELD, TRANS MT(FRT HEAT)	10036598
12.	N17	4.081	MOUNT, TRANS RR	10046808
13.	N17	4.081	MOUNT, TRANS FRT	10046804
14.	D9	0.027	MOUNT, ENG	14073097
15.	D9	0.029	BRACKET, ENG MT (2.5L)	10023655
16.	D9	0.029	STRUT, ENG MT	10046816
17.		8.900	BOLT, HEX (M10X1.5X85)	
18.	N17	4.081	BRACKET, TRANS MT(RR)(MT2)	10033681
19.	N17	4.081	BRACKET, TRANS MT(FRT)(MT2)	10033682
20.		8.929	WASHER, FL (M10X20X3)	10000925
21.		8.900	BOLT, HWH (M10X1.5X25) 10.9 PH	11502788
22.	N26	9.023	BUSHING, FRT FRAME MTG	10029677
		8.900	BOLT, HEX (M12X1.75X105)(10.9 PC)	11506584

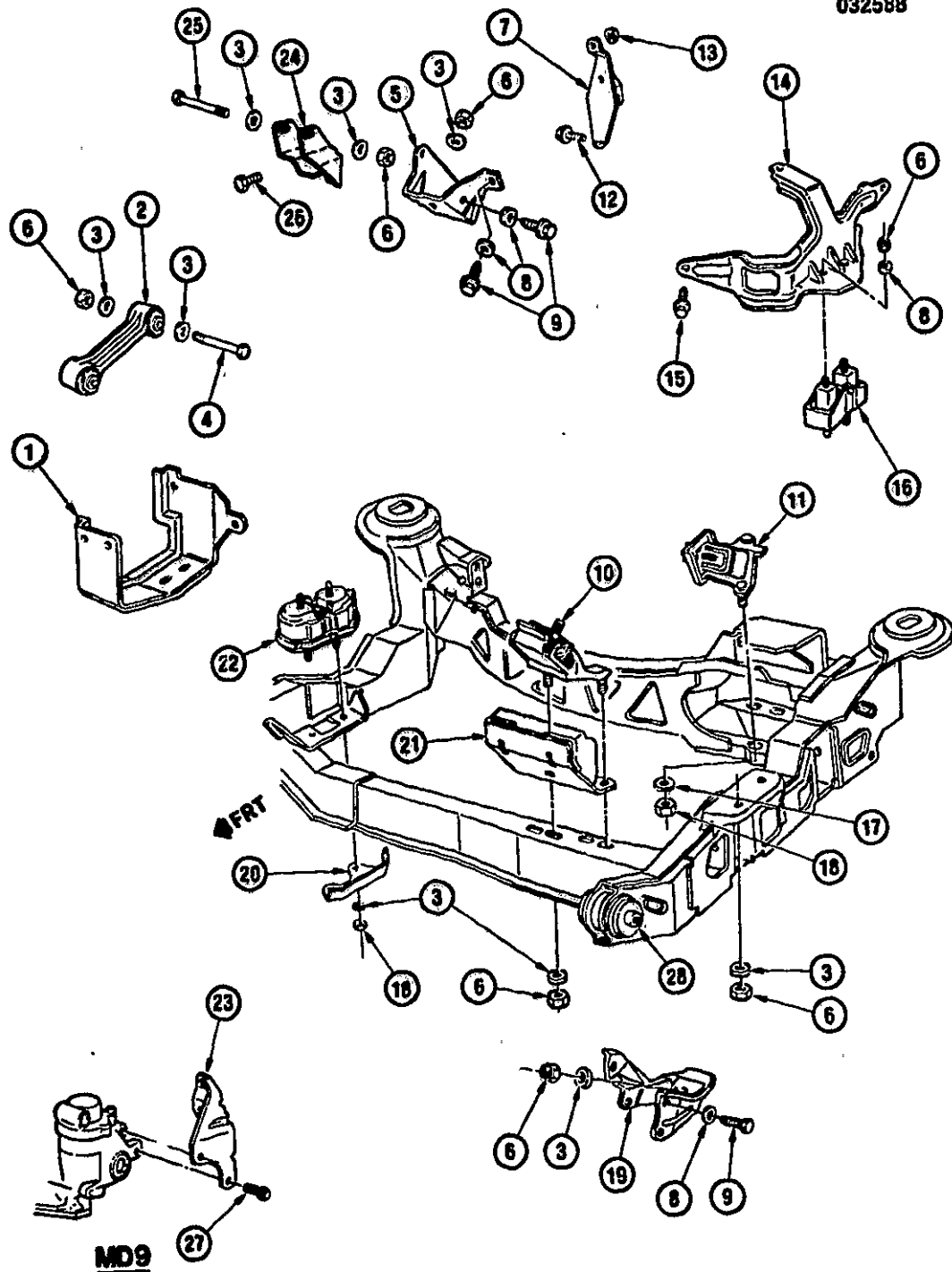

1986-1989 P ENGINE & TRANSMISSION MOUNTING-L4 (LR6/2.5R)

1.	D9	0.029	BRACKET, ENG MT-W/MT(MT2)(1986-87)	10023655
	D9	0.029	BRACKET, ENG MT-W/AT (MD9)(1986-87)	14106628
	D9	0.029	BRACKET, ENG MT (1988)	14094485
2.	D9	0.029	STRUT, ENG MT	10046616
3.		8.929	WASHER, SPL STL (15/32 IDX1 1/8 ODX1/8)	3790769
4.		8.900	BOLT, HEX (M10X1.5X85)10.9 POR	11504599
5.	N17	4.081	BRACKET, TRANS MT(FRT)(MT2)	10033682
6.		8.917	NUT, HEX PREV TO (M10X1.5) 10 CAD	11501033
7.	N17	4.081	BRACE, TRANSAXLE (MD9)(1987 1ST DES)(*1)	10005334
	N17	4.081	BRACE, TRANSAXLE (1988)	14087690
8.		8.929	WASHER, FL (M10X20X3 THK HARDENED STL C)	10000925
9.		8.900	BOLT, HEX (M10X1.5X25) 10.9 POR	11504598
10.	N17	4.081	MOUNT, TRANS FRT	10046504
	N17	4.081	MOUNT, TRANS FRT (1988)(2.8-9)	10053657
	N17	4.081	MOUNT, TRANS FRT (1988)(2.5R)	10084947
11.	N17	4.081	MOUNT, TRANS RR	10046508
	N17	4.081	MOUNT, TRANS RR (1988)	10093226
12.		8.900	BOLT, LRG HFH (M10X1.5X30 9.8 P)	11502689
13.		8.917	NUT, HFH (M10X1.5X10 POR 10)	11508101
14.	N17	4.081	BRACKET, TRANS MT RR (MD9)	10032922
15.		8.900	BOLT, HWH (M10-1.5X25)10.9 PH	11502788
16.	N17	4.081	MOUNT, TRANS	10084949
17.		8.929	WASHER, FL (M8X20X2.5 THK HARDENED STL)	11501623
18.		8.917	NUT, HEX TORQ PREV (M8X1.25) 10 CAD	11500760
19.	N17	4.081	BRACKET, TRANS MT (RR)(MT2)	10033681
20.	D9	0.029	SHIELD, ENG MT-W/AT (MD9)	10036929
21.	N17	4.083	SHIELD, TRANS MT (FRT HT)	10036586
22.	D9	0.027	MOUNT, ENG-W/AT (MD9)	17983984
23.	N17	4.081	BRACE, TRANSAXLE (2ND DES 1987)(1988)(*1)	14087690
24.	D9	0.029	BRACKET, ENG MT STRUT	10046480
25.		8.900	BOLT, HEX (M10X1.5X95) 10.9 POR	11505901
26.	F23	2.277	SCREW, HEX HD (M10X1.5-8G THD)	10008894
27.		8.900	BOLT, HFH (M10X1.5X20)9.8 PZOR	11508202
28.	N26	8.023	BUSHING, FRT FRAME MTG	10029677
		8.900	BOLT, HEX (M12X1.75X200)(10.9 PC)	11504439

NOTE 1: 1ST DES IDENT BY ALUMINUM CASING, 2ND DES IDENT BY STEEL STAMPING.

2P00-011
032588

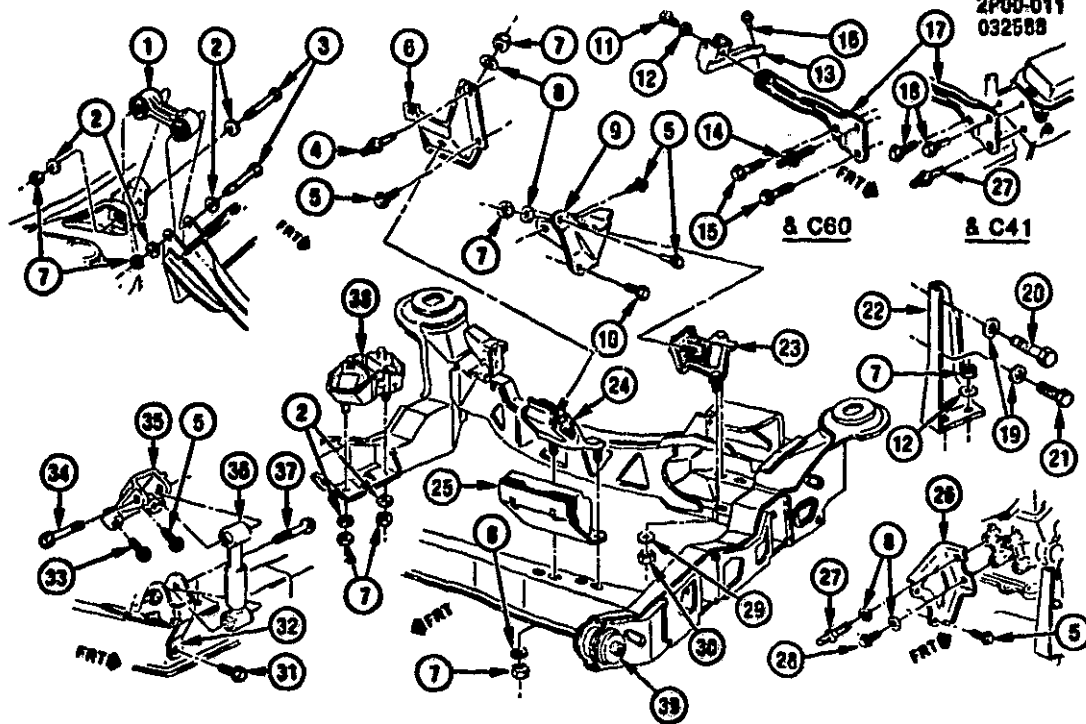

2P00-011

1986 P ENGINE & TRANSMISSION MOUNTING-V6 (L44/2.8-9)(MD9-A.T.)

1.	D9	0.027	STRUT, ENG MT (1986)	10046818
	D9	0.027	STRUT, ENG MT (1987)	10046818
2.		8.929	WASHER, SPL STL (15/32 IDX1 1/8 ODX1/8)	3790768
3.		8.900	BOLT, HEX (M10X1.5X85) 10 9 POR	11504599
4.	N17	4.081	STUD, TRANS MT BRKT	10036762
5.		8.900	BOLT, HWH (M10X1.5X25) 10 9 PH	11502788
6.	N17	4.081	BRACKET, TRANS MT (FRT)	14038338
7.		8.917	NUT, HEX PREV TQ (M10X1.5) 10 CAD	11501033
8.		8.929	WASHER, SPL STL (15/32 IDX1 1/8 ODX1/8)	3790768
9.	N17	4.081	BRACKET, TRANS MT RR	10093238
10.		8.900	BOLT, FLG HEX HD (M10-1.5 X 45)(10.9 POR)	11508331
11.		8.900	BOLT, HEX (M10X1.5X30) 10 9 PC	11500930
12.		8.929	WASHER, FL (M10X20X3)CP	10000825
13.	D9	0.029	BRACKET, ENG MT STRUT	10068737
14.	D9	0.002	STUD, ENG MT STRUT BRKT (1 073)	1819032
15.		8.900	BOLT, HEX (M10X1.5X60 35) 10 9 POR	11508285
16.		8.900	BOLT, HFH (M10X1.5X20) 9 8 PC	11502885
17.	D9	0.029	BRACKET, ENG MT STRUT REINF	10038289
18.		8.900	BOLT, HFH (M10X1.5X20) 9.8 PC	11502885
19.	N17	4.085	WASHER, TRANS MT BRKT (0 002)	473839
20.	D9	0.029	BOLT, ENG MT BRKT	10034857
21.		8.900	BOLT, HEX (M12X1.75X30) 10 9 PZOR	11508133
22.	D9	0.029	BRACKET, ENG MT	10033888
23.	N17	4.081	MOUNT, TRANS RR	10046808
24.	N17	4.081	MOUNT, TRANS FRT	10046804
25.	N17	4.083	SHIELD, TRANS MT(FRT MT)	10038898
26.	N17	4.081	BRACE, TRANSAXLE	14089785
27.	N17	4.081	STUD, TRANSAXLE BR (4 085)	14101259
28.		8.900	BOLT, HEX (M10X1.5X20) 10 9 POR	11504585
29.		8.929	WASHER, (M8.9X20 4X2 5) CAD/ZP (7347)	14038397
30.		8.917	NUT, HEX TORQ PREV (M8X1.25) 10 CAD	11500760
31.		8.900	BOLT, HFH (M8X1.25X16) 9.8 PC	11507022
32.	N17	4.081	BRACKET, DRIVE LINE VIB ABS LWR	10033887

33.		8.900	BOLT, HFH TORQ PR (M10X1.5X30)PC	1635490
34.		8.900	BOLT, HFH (M8X1.25X75) 9.8 POR	11508301
35.	N17	4.081	BRACKET, ABS UPR	10032594
36.	N17	4.081	ABSORBER, DRIVE LINE VIB	22048473
37.		8.900	BOLT, HEX (M8X1.25X45) CAD BR	11508088
38.	D9	0.027	MOUNT, ENG	14073097
39.	N26	9.023	BUSHING, FRT FRAME MTG	10029877
		8.900	BOLT, HEX (M1.2X1.75X200)(10.9 PC)	11504438

2P00-017
032588

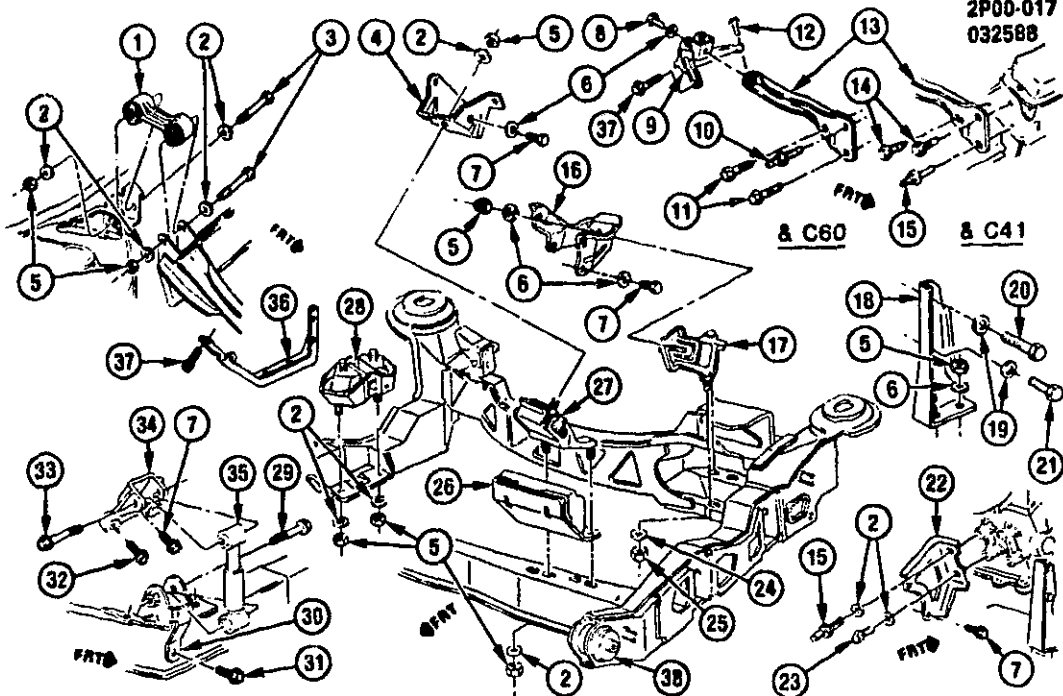

2P00-017

1986-1988 P ENGINE & TRANSMISSION MOUNTING-V6 (L44/2.9-9)(MT2-M.T.)

1.	D9	0.027	STRUT, ENG MT	10046818
2.		8.929	WASHER, SPL STL (16/32 IDX1 1/8 ODX1/8)	3790768
3.		8.900	BOLT, HEX (M10X1 5X85) 10 9 POR	11504698
4.	N17	4.081	BRACKET, TRANS MT (FRT)(MT2)	10033682
5.		8.917	NUT, HEX PREV TQ (M10X1 5) 10 CAD	11501033
6.		8.929	WASHER, FL (M10X20X3)CP	10000926
7.		8.900	BOLT, HWH (M10X1 5X25) 10 9 PH	11502788
8.		8.900	BOLT, HEX (M10X1 5X30) 10 9 PC	11500930
9.	D9	0.029	BRACKET, ENG MT STRUT	10088737
10.	D9	0.002	STUD, ENG MT STRUT BRKT (1 073)	1819032
11.		8.900	BOLT, HEX (M10X1 5X60 35) 10 9 POR	11509265
12.		8.900	BOLT, HFH (M10X1.5X20) 9 8 PC	11502685
13.	D9	0.029	BRACKET, ENG MT STRUT REINF	10038289
14.		8.900	BOLT, HFH (M10-1 5X20) 9 8 PC	11502685
15.	D9	0.029	STUD, ENG MT STRUT BRKT TO CYL HD LWR	14101259
16.	N17	4.081	BRACKET, TRANS MT (RR)(MT2)	10033681
17.	N17	4.081	MOUNT, TRANS RR	10046808
18.	D9	0.029	BRACKET, ENG MT (1986-87)	10033686
19.	D9	0.002	WASHER, ENG MT BRKT TO CYL BLK	473639
20.	D9	0.029	BOLT, ENG MT BRKT	10034667
21.		8.900	BOLT, HEX (M12X1 75X30) 10 9 PZOR	11508133
22.	N17	4.081	BRACE, TRANSAXLE	14089765
23.		8.900	BOLT, HEX (M10X1.5X20) 10 9 POR	11504695
24.		8.929	WASHER, (M8.9X20.4X2.5) CAD/ZP (7347)	14038397
25.		8.917	NUT, HEX TORQ PREV (M8X1 25) 10 CAD	11500760
26.	N17	4.083	SHIELD, TRANS MT (FRT HT)	10036596
27.	N17	4.081	MOUNT, TRANS FRT	10046804
28.	D9	0.027	MOUNT, ENG-RH (1986-87)	14073097
	D9	0.027	MOUNT, ENG-RH (1988)	17986951
29.		8.900	BOLT, HEX (M8X1.25X46) CAD BR	11505068
30.	N17	4.081	BRACKET, DRIVE LINE VIB ABS LWR (1986-87)	10033887
31.		8.900	BOLT, HFH (M8X1.25X16) 9 8 PC	11507022
32.		8.900	BOLT, HFH (M10X1 5X30) 9 8 PC	11502689
33.		8.900	BOLT, HFH (M8X1.25X75) 9 8 POR	11508301
34.	N17	4.081	BRACKET, DRIVE LINE VIB ABS UPR (1986-87)	10032594
35.	N17	4.081	ABSORBER, DRIVE LINE VIB (1986-87)	22046473

36.	D9	0.029	BRACKET, ENG MT	10113140
37.		8.900	BOLT, HFH (M10X1 5X40X36 THD)	11508844
38.	N26	9.023	BUSHING, FRT FRAME MTG	10029677
		8.900	BOLT, HEX (M12X1 75X200X10 9 PC)	11504439

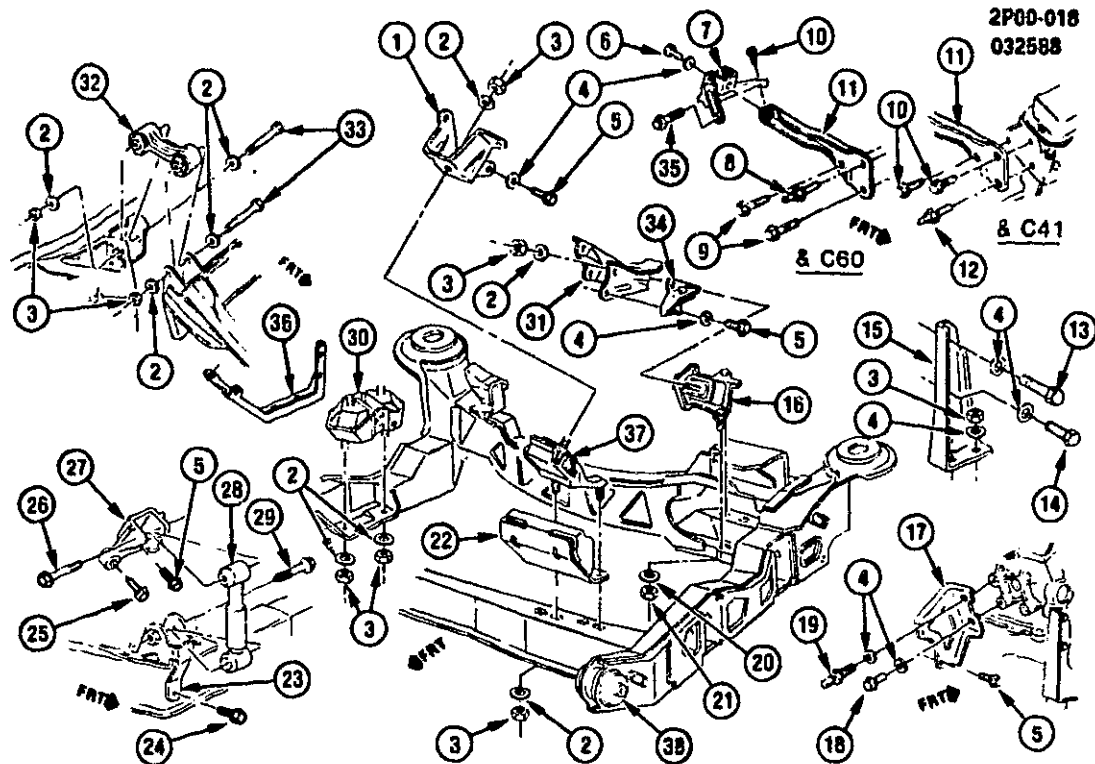

2P00-018

1987-1988 P ENGINE & TRANSMISSION MOUNTING-V6 (L44/2.8-9)(MG2-M.T.)

1.	N17	4.083	BRACKET, TRANS MT (FRT)	10040249
2.		8.929	WASHER, SPL STL (15/32 IDX1 1/8 ODX1/8)	3790768
3.		8.917	NUT, HEX PREV TORQ (M10X1 5) 10 CAD	11501033
4.		8.929	WASHER, FL (M10X20X3)CP	10000925
5.		8.900	BOLT, HWH (M10X1 5X25) 10 9 PH	11502788
6.		8.900	BOLT, HEX (M10X1 5X30) 10 9 PC	11500930
7.	D9	0.029	BRACKET, ENG MT STRUT (2 8-9)	10088737
8.	D9	0.002	STUD, ENG MT STRUT BRKT (1 073)	1619032
9.		8.900	BOLT, HEX (M10X1 5X60 35) 10 9 POR	11509265
10.		8.900	BOLT, HEX FLG (M10X1 5X20) 9 8 PC	11502685
11.	D9	0.029	BRACKET, ENG MT STRUT REINF (2 8-9)	10038289
12.	D9	0.029	STUD, ENG MT STRUT BRKT TO CYL HD LWR (2 8-9 W/C41)	14101259
		8.929	WASHER, FL (M10 8X18 54X1 95) PS	11509161
13.	D9	0.029	BOLT, ENG MT BRKT	10034657
14.		8.900	BOLT, HEX (M12X1 75X30) 10 9 PZOR	11508133
15.	D9	0.029	BRACKET, ENG MT	10033686
16.	N17	4.081	MOUNT, TRANS RR	10046808
17.	N17	4.081	BRACE, TRANSAXLE	14089765
18.		8.900	BOLT, HEX (M10X1 5X20) 10 9 POR	11504595
19.	N17	4.081	STUD, TRANSAXLE BR (4 085)	14101259
20.		8.929	WASHER, FL (M8X20X2 5)	11501623
21.		8.917	NUT, HEX TORQ PREV (M8X1 25) 10 CAD	11500780
		8.917	NUT, HEX TORQ PREV (M8X1 25) 10 CAD	11500760
22.	N17	4.083	SHIELD, TRANS MT (FRT HT)	10036698
23.	N17	4.081	BRACKET, DRIVE LINE VIB ABS LWR	10033687
24.		8.900	BOLT, HEX FLGD (M8X1 25X16) 9 8 PC	11507022
25.		8.900	BOLT, HFH (M10X1 5X30) 9 8 PC	11502689
26.		8.900	BOLT, HFH (M8X1 25X7.5) 9 8 POR	11508301
27.	N17	4.081	BRACKET, DRIVE LINE VIB ABS UPR	10032694
28.	N17	4.081	ABSORBER, DRIVE LINE VIB	22046473
29.		8.900	BOLT, HEX (M8X1 25X45) CAD BR	11508088
30.	D9	0.027	MOUNT, ENG (1987)	14073097
	D9	0.027	MOUNT, ENG (1988)	17988951

31.	N17	4.081	MOUNT, TRANS FRT (1987)	10048804
	N17	4.081	MOUNT, TRANS FRT (1988)	10053857
32.	D9	0.027	STRUT, ENG MT	10048818
33.		8.900	BOLT, HEX (M10X1 5X85) 10 9 POR	11504598
34.	D9	0.027	BRACKET, ENG & TRANS ROLL BPR	10053778
35.		8.900	BOLT, HFH (M10X1 5X4J)36 THD)10 9 PS	11508844
36.	D9	0.027	BRACKET, ENG MT (1988)	10113140
37.	N17	4.081	MOUNT, TRANS FRT	10053857
38.	N26	9.023	BUSHING, FRT FRAME MIG	10028577
		8.900	BOLT, HEX (M12X1 75X200)10 9 PC)	11504439

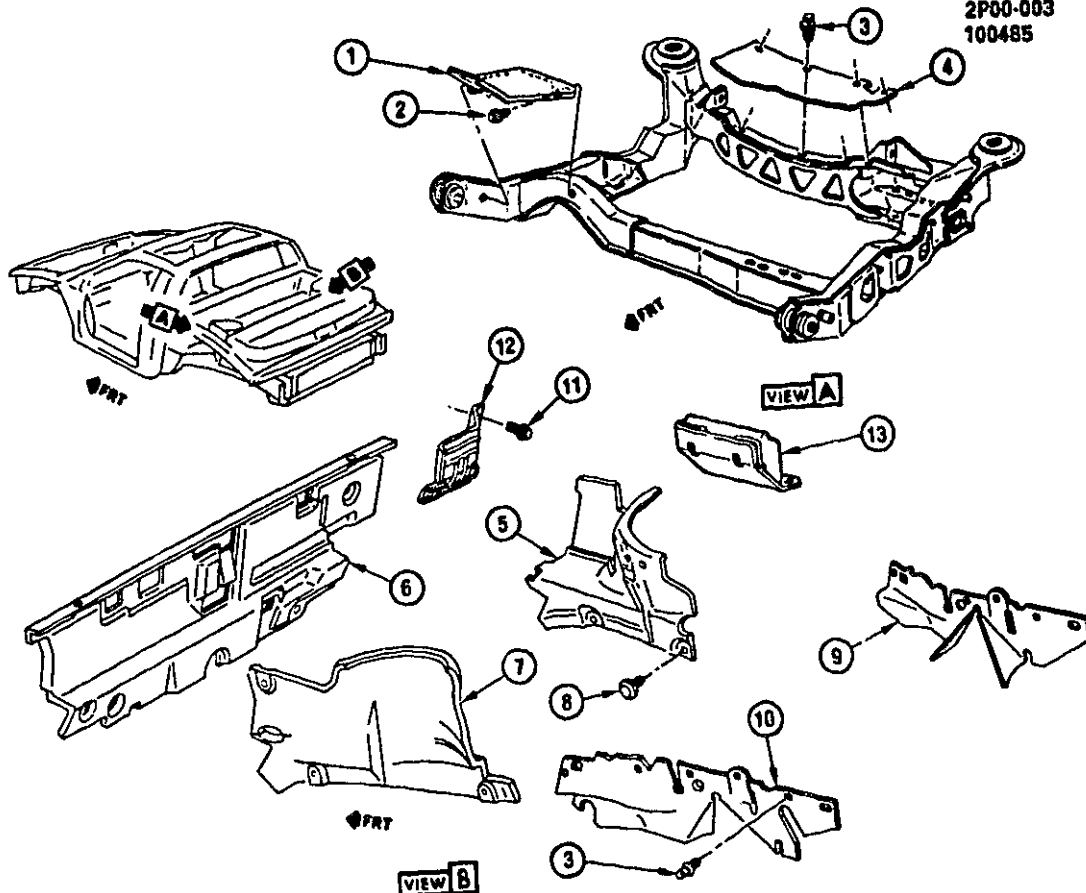

2P00-003

1984 P ENGINE INSULATORS & SPLASH SHIELDS

1.	N26	9.171	SHIELD, CMPR SPH	10038173
2.		8.977	SCREW, HWH TAP(M6 3 X 1 81 X 16)	
3.	N25	8.153	RETAINER, PUSH-IN (1 276)	20864092
4.	N27	12.982	SHIELD, ENG SPH RR	10028479
5.		N.S.	INSULATOR, ENG COMPT-RH	
6.	N27	12.982	INSULATOR, ENG COMPT-FRT	10031689
7.	N27	12.982	INSULATOR, ENG COMPT-LH	10040840
8.		8.934	RETAINER, INSULATOR	
9.	N27	12.982	SHIELD, ENG SPH-RH	10071602
10.	N27	12.982	SHIELD, ENG SPH-LH	10071601
11.		8.977	SCREW, HWH TAP (M6 3 X 1 81 X 16)	
12.	N27	13.090	SHIELD, BODY WRG HARN HEAT	10031923
13.	N17	4.083	SHIELD, TRANS MT (FRT HT)	10036596

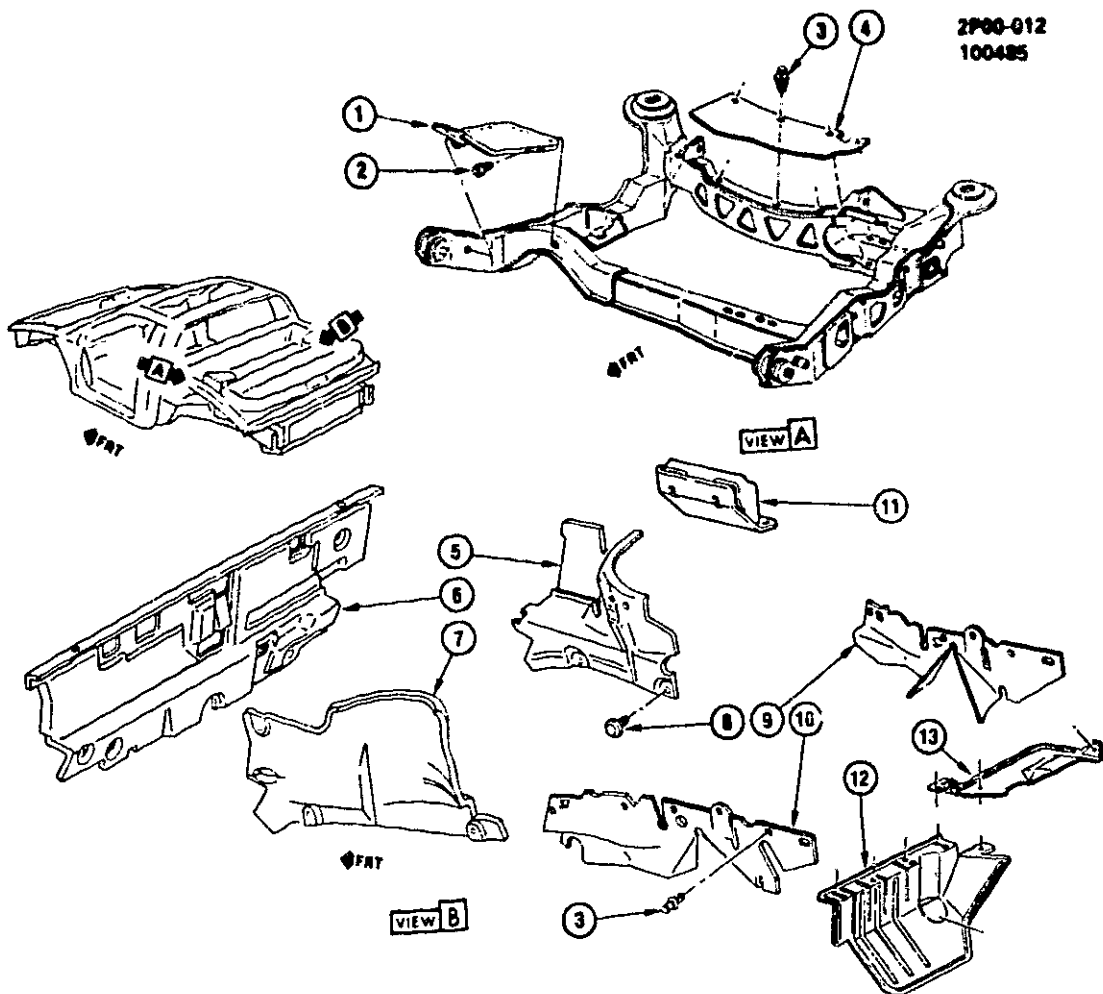

2P00-012

1985 P ENGINE INSULATORS & SPLASH SHIELDS

1.	N26	9.171	SHIELD, CMPR SPH-W/C60	10038173
2.		8.977	BOLT, HWH TAP (M6 3X1 81X16)	
3.	N25	8.163	RETAINER, ENG SPH SHLD (1 276)	20864092
4.	N27	12.982	SHIELD, ENG SPH RR (1985)	10028479
5.	N27	12.982	INSULATOR, ENG COMPT SI SOUND ABS-RH	10103744
6.	N27	12.982	INSULATOR, ENG COMPT FRT	10038017
7.	N27	12.982	INSULATOR, ENG COMPT SI SOUND ABS-LH	10040840
8.		8.950	RETAINER, PUSH-IN (1 1/32" LEN 1/4" HOLE)	
9.	N27	12.982	SHIELD, ENG SPH-RH	10071602
10.	N27	12.982	SHIELD, ENG SPH-LH	10071601
11.	N17	4.083	SHIELD, TRANS MT (FRT HT)	10036596
12.	N27	12.982	SHIELD, ENG COMPT RR DUST-RH	10040980
13.	N27	12.982	SHIELD, ENG COMPT RR DUST-LH	10042411

2P00-013
100485

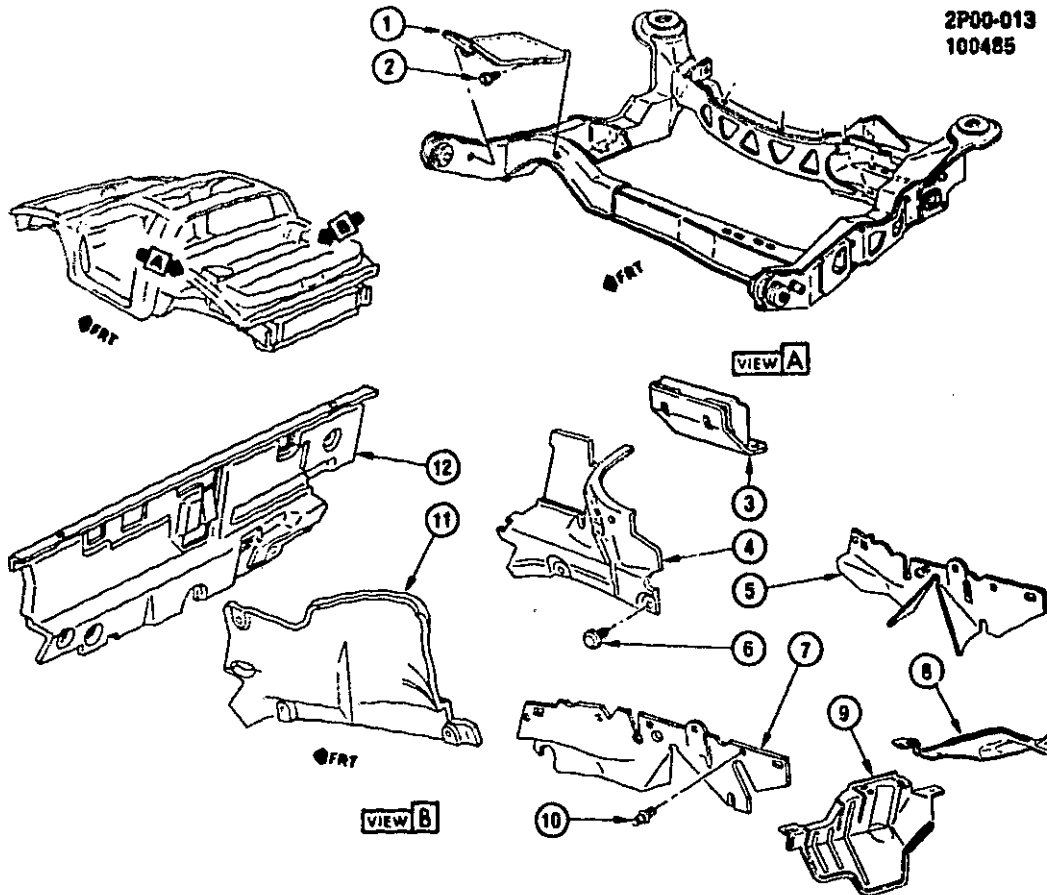

2P00-013

1986-1988 P ENGINE INSULATORS & SPLASH SHIELDS

1.	N26	9.171	SHIELD, CMPR SPH-W/A C	10038173
2.		8.977	BOLT, SEMS HWH (M6 3X1 81X20 AB)	12337828
3.	N17	4.093	SHIELD, TRANS MT(FRT HT)	10036596
4.	N27	12.982	INSULATOR, ENG COMPT SI (SOUND ABS)-RH	10103744
5.	N27	12.982	SHIELD, ENG SPH (1986)	10071602
	N27	12.982	SHIELD, ENG SPH-RH (1987)	10071602
	N27	12.982	SHIELD, ENG SPH (1988)	10092180
6.		8.950	RETAINER, PUSH-IN (Ø 35-LEN 1/4" HOLE)	3977776
7.	N27	12.982	SHIELD, ENG SPH-LH	10071601
8.	N27	12.982	SHIELD, ENG COMPT RR DUST-LH (1986)	10042411
9.	N27	12.982	SHIELD, ENG COMPT RR DUST-RH	10040980
10.	N25	8.163	RETAINER, ENG SPH SHLD (1 276)	20884092
11.	N27	12.982	INSULATOR, ENG COMPT SI(SOUND ABS)-LH	10040840
12.	N27	12.982	INSULATOR, ENG COMPT FRT (1986)	10039017

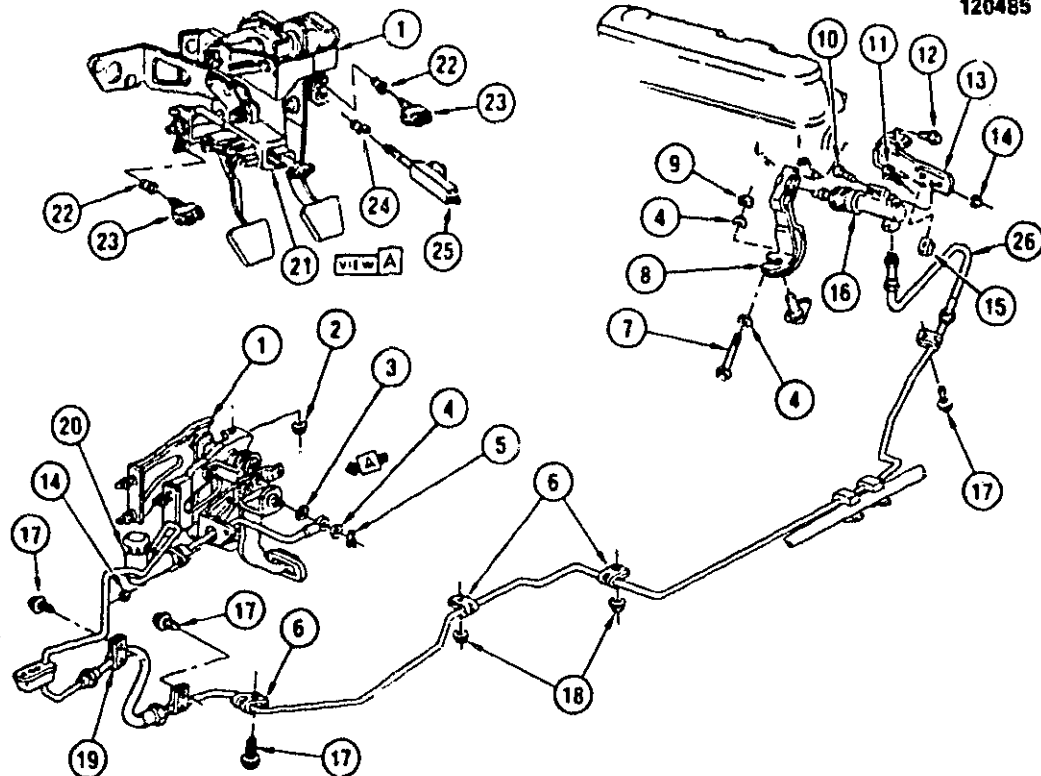

2P00-002

1984 P CLUTCH LINKAGE

1.	N.S.	PEDAL, BRK & CLU	
2.	8.917	NUT, HEX (M8 X 1 25)	
3.	8.928	WASHER (49/64" OD X 37/64" ID)	
4.	8.929	WASHER, FL (13/32" X 13/16" X 1/16" ZN)	
5.	8.934	RETAINER, TYPE B (062 SPR STL)	
6.	4.686	CLIP, RR BRK PIPE (CLSD TYPE)(3 162)(*1)	
7.	8.900	BOLT, HEX (M10 X 1 5 X 55)	22518924
	8.929	WASHER, FL (13/32" X 13/16" X 1/16" ZN)	
8.	D9	LEVER, CLU FORK	10054118
9.	8.915	NUT, HEX (M10 X 1 5)	
10.	8.900	BOLT, HEX (M8 X 1 25 X 40)	
11.	8.900	BOLT, HWD (M10 X 1 5 X 20)	
12.	8.900	BOLT, HWH (M10 X 1 5 X 25)	
13.	D9	0.782 BRACKET, CLU ACTR CYL	10028098
14.	8.917	NUT, HEX (M8 X 1 25 TORQUE PREV 10)	
15.	8.921	NUT, U-SHAPE (M10 X 1 5)	
16.	D9	0.780 CYLINDER, ACTUATOR	10026328
17.	8.977	SCREW, HWH TAP (M6 3 X 1 81 X 16)	
18.	8.915	NUT, HEX (STYLE 2)(M6 X 1)	
19.	8.950	CLIP, CLOSED STL (7/16" X 5/16" ZN)	
20.	D9	0.775 CYLINDER, CLU MASTER	10142033
21.	N17	4.054 SWITCH, CLU START	10045862
22.	N16	3.885 RETAINER, SWITCH	1612303
23.	N16	3.883 SWITCH, CRUISE CONT VAC REL (BRK & CLU)	10024217
24.	G2	2.447 RETAINER, STOP LP SW	22534165
25.	G2	2.447 SWITCH, STOP LP & CRUISE	25524845
26.	D9	0.785 PIPE, CLU ACTR CYL	14105603

NOTE 1 HOLE MUST BE ENLARGED TO 11/32"

2P00-005
072985

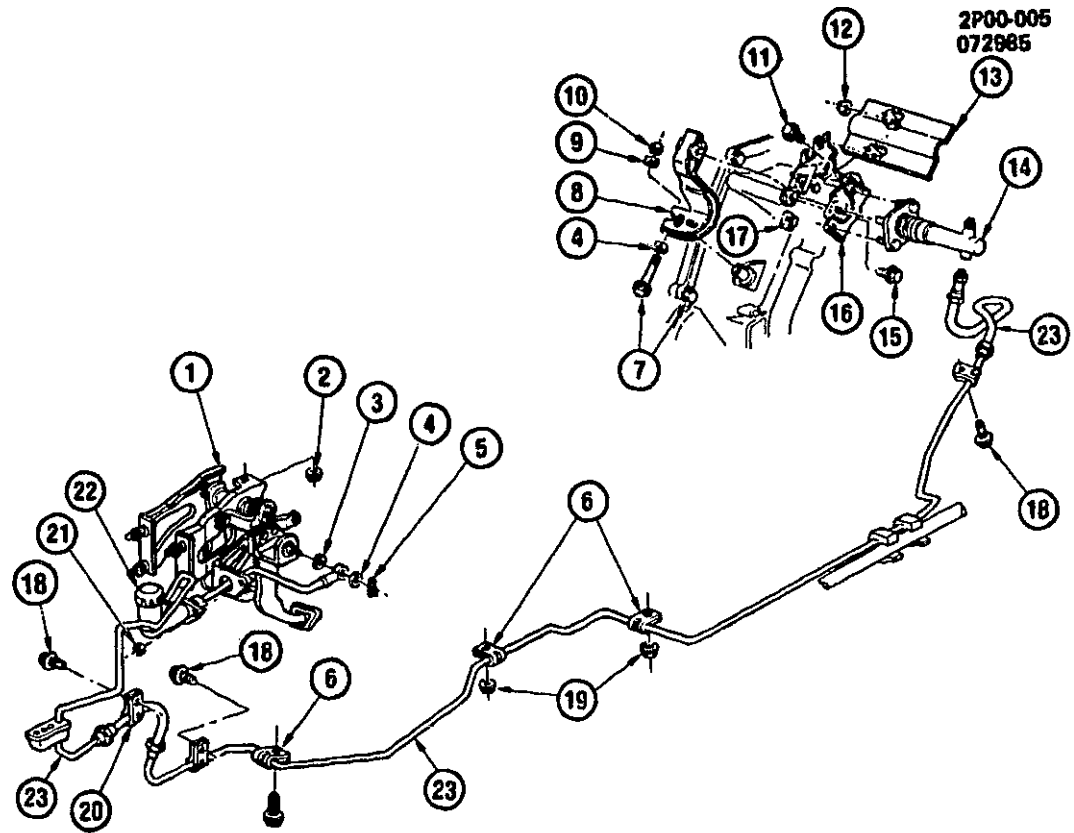

2P00-005

1985 P CLUTCH LINKAGE

1.	N.S.	PEDAL, BRK & CLU	
	N20	COVER, BRK PED (A/T)	1256203
	N20	COVER, BRK PED PAD (M/T)	14009148
2.	8.915	NUT, HEX (M8 X 1 25 X 7 8)(W/CAST IRON HD)	
3.	8.928	WASHER, SPRING (29/64"X1 1/16"X5/64")	
4.	8.929	WASHER, FL (7/16"X3/4"X1/16")	
5.	8.934	RETAINER, TYPE B (062)	
6.	8.950	CLIP, 1/4 OR 5/16 PIPE (17/32 X 1/2")	343464
7.	8.900	BOLT, HEX (M10-1 5X55)	
8.	D9	LEVER, CLU FORK	10054119
9.	8.929	WASHER, FL (9/64"X 13/16"X 1/16")	
10.	8.916	NUT, HEX (M10X1 5X9)	
11.	8.900	BOLT, HEX FLGD HD (M10X1 5X30 9 8)	
12.	8.917	NUT, HEX TORQ PREV (M8X1 25) 10 CAD	
13.	D9	SHIELD, CLU ACTR CYL HT	10039908
14.	D9	CYLINDER, CLU ACTR	10036044
15.	8.900	BOLT, HFH (M10X1 5X30)	
16.	D9	BRACKET, CLU ACTR CYL (2 5R)	10028098
17.	N9	NUT, U SHAPE (M10X1 5)	
18.	8.977	BOLT, HEX W/FL WA (M6 3 X 1 81 X 20)	
19.	8.916	NUT, HEX(STYLE 2) (M6X1)	
20.	8.950	CLIP, 1/4 OR 5/16 PIPE (17/32 X 1/2")	343464
21.	8.917	NUT, HEX TORQ PREV (M8X1 25) 10 CAD	
22.	D9	CYLINDER, CLU MASTER	10142033
23.	D9	PIPE, CLU ACTR CYL	14105603

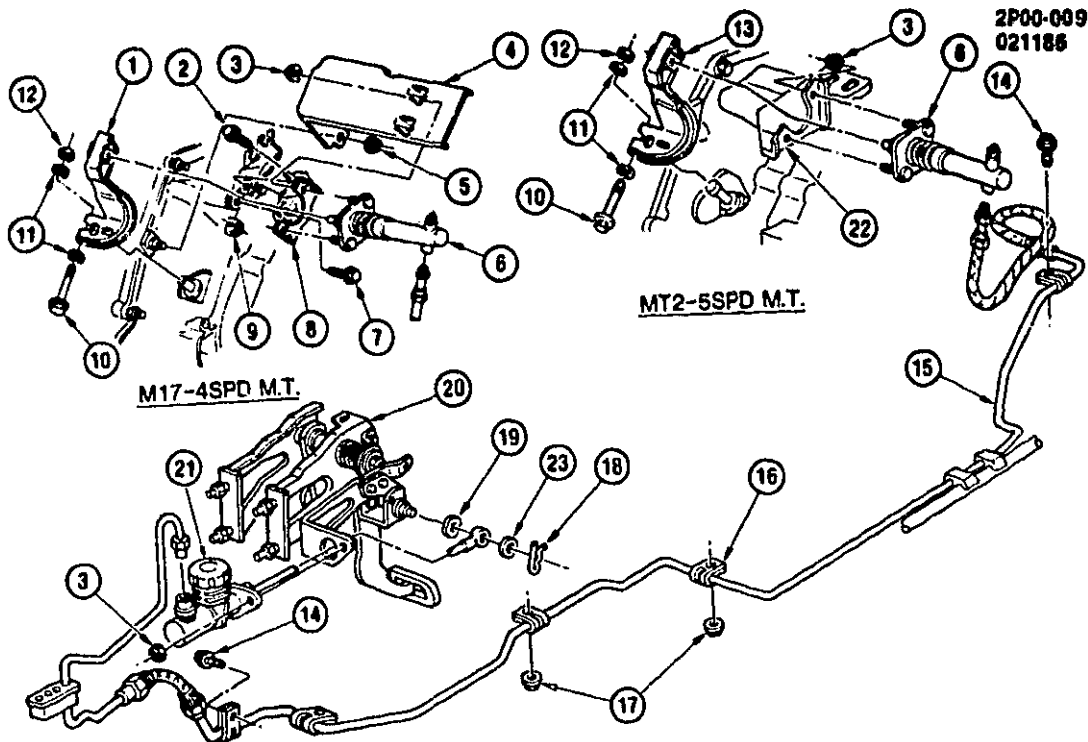

2P00-009

1986 P CLUTCH LINKAGE

1.	D9	0.805	LEVER, CLU FORK-W/M17	10054119
2.		8.900	BOLT, LRG HWH (M10X1 5X30 9 B)	1835490
3.		8.917	NUT, HEX TORQ PREV (M8X1 25) 10 CAD	11500760
4.	D9	0.777	SHIELD, CLU ACTR CYL-W/2 8-9, M17	10039908
5.		8.917	NUT, TORQ PREV HWH (M10X1 5 10 CAD)	11502812
6.	D9	0.780	CYLINDER, CLU ACTR	10035044
7.		8.900	BOLT, HEX (M12X1 75X45 9 8 PC)	11500844
8.	D9	0.782	BRACKET, CLU ACTR CYL-W/M17	10038180
9.		8.921	NUT, U-SHAPE (M10X1 5 THD POR 33 LONG)	22531616
10.		8.900	BOLT, HEX (M10-1 5X55 PHOS 10 9)	11502804
11.		8.929	WASHER, FL (15/32X15/16X1/16) ZC	120395
	D9	0.775	BUSHING, PUSH ROD(*4)	14094900
12.		8.915	NUT, HEX (M10X1 5X9 PC 10)	11500424
13.	D9	0.805	LEVER, CLU FORK-W/MT2	10054300
14.		8.977	BOLT, SEMS HWH (M6 3X1 81X20 AB)	12337828
15.		N.S.	PIPE, CLU ACTR CYL	
16.		N.S.	CLIP, PIPE	
17.		8.917	NUT, HFH (M6X1X6 5)	11603747
18.		8.934	RETAINER, TYPE B (062 SPRING STEEL)	10040797
19.		8.928	WASHER, SPRING (453X 688X 007)	410230
20.		N.S.	PEDAL ASM, CLU & BRK(*1)	
21.	D9	0.775	CYLINDER, CLU MASTER(*2)	10142033
	D9	0.775	CYLINDER, CLU MAS (2ND DES & 3RD DES)(*3)	10079730
	D9	0.775	BUSHING, PUSH ROD(*4)	14094900
22.	N17	4.047	BRACKET, TRANS SEL SHFT LVR CBL BRKT-W/2 5R	10037898
23.		8.929	WASHER, STEEL (441X 750X 060) PH. HARDEN	492346

NOTE 1 SEE GROUP 0 000 ART #2P00-010 FOR PEDAL DETAILS

NOTE 2 1ST DESIGN-IDENT BY CAST IRON BODY. PIPE ATTACHED BEHIND THERESEVOIR

NOTE 3 2ND DESIGN-IDENT BY TUBE BODY.PIP IN FRT OF RESEVOIR

NOTE 4 3RD DESIGN-IDENT BY PLASTIC BUSHING IN PEDAL ACTUATOR ROD

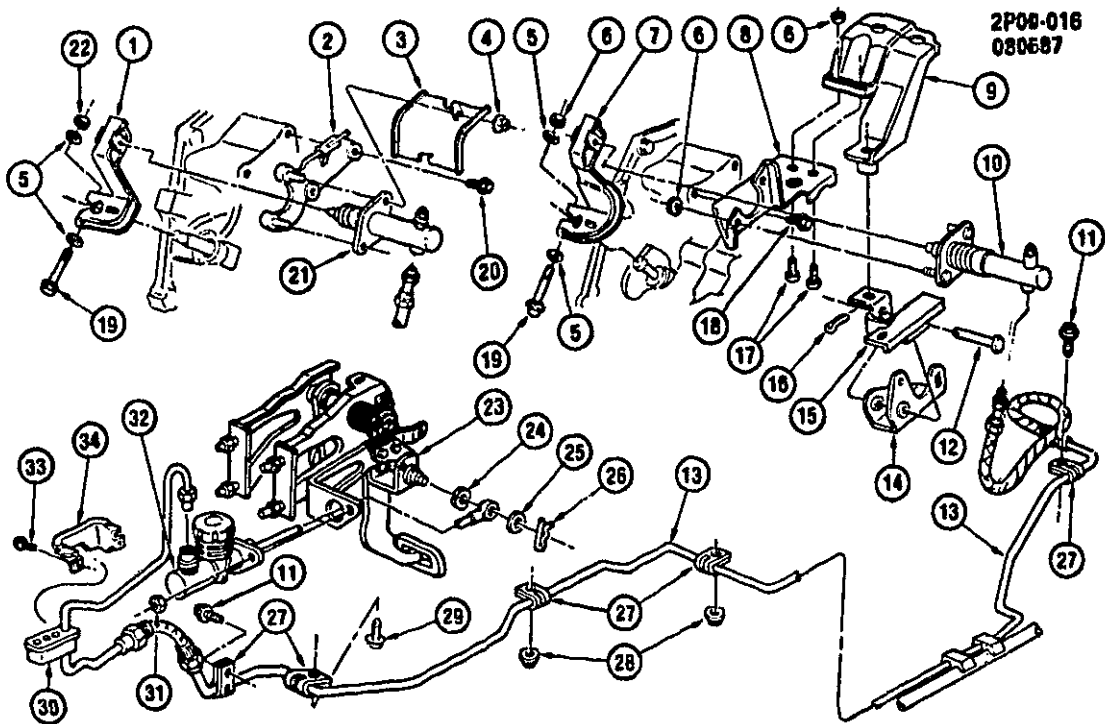

2P00-016

1987-1988 P CLUTCH LINKAGE

1.	D9	0.805	LEVER, CLU FORK (1986-87 MG2)	14105798
2.	N17	4.047	BRACKET, SHFT LVR CBL(*2)	10040978
3.	D9	0.777	SHIELD, CLU ACTR CYL HT (MG2)(1987)	10038879
4.	F17	2.251	NUT, HEX (M8 X 1 25 X 7 8)(W/CAST IRON HD)(0 334)	22521550
5.		8.929	WASHER, FL (406X 812X 065) FLUORO CARBON	120395
6.		8.917	NUT, HEX TORQ PREV (M8X1 25) 10 CAD	11500760
7.	D9	0.805	LEVER, CLU FORK (MT2)	10054300
8.	N17	4.047	BRACKET, TRANS SEL SHFT LVR CBL (2 5R)	10037898
9.	N17	4.047	BRACKET, TRANS SEL SHFT LVR CBL (MT2)	10038294
10.	D9	0.780	CYLINDER, CLU ACTR (MT2 M17)	10035044
11.		8.977	BOLT, HWH TAP (M6 3X1 81X16) POR	12337828
12.	N17	4.008	PIN, TRANS SEL LVR PIV (2 5R MT2)	477095
13.	D9	0.785	PIPE, CLU ACTR CYL (MG2.MT2)(1987)	14105670
	D9	0.785	PIPE, CLU ACTR CYL (MG2.MT2)(1988)	10054238
14.	N17	4.045	LEVER, TRANS SEL (2 5R W/MT2)	10086490
15.	N17	4.047	BRACKET, TRANS SEL LVR (2 5R)	10034203
16.		8.934	SPRING, TYPE B SPRING-STL (M1 12X 24X61) PEOR	10040797
17.		8.900	BOLT, HFH (M8X1 25X25) 10 9 PC	11509511
18.		8.900	BOLT, HWH (M10X1 5X25) 10 9 PH	11502788
19.		8.900	BOLT, HEX M10-1 5X55) 10 9 PHOS	11502804
20.		8.900	BOLT, LRG HFH (M10X1 5X30) 9 8 PC	11502689
21.	D9	0.780	CYLINDER, CLU ACTR (MG2)	10038878
22.		8.916	NUT, HEX (M10X1 5X9) 10 PC	11500424
23.		N.S.	PEDAL ASM, CLU(*1)	
24.		8.928	WASHER, SPRING (453X 688X 007)PL	410230
25.		8.929	WASHER (441X 750X 060) PH	492346
26.		8.934	SPRING, TYPE B SPRING-STL (1 12X 24)	10040797
27.		8.950	CLIP, 1/4 OR 5/16 PIPE (17/32 X 1/2")	343464
28.		8.917	NUT, HFH (M6X1X6 5) 9 ZOR	11503747
29.		8.977	SCREW, HWH TAP (M6 3X1 81X16) POR	22527475
30.	N20	4.665	INSULATOR, FRT BRK PIPE	10024395
31.		8.917	NUT, HEX TORQ PREV (M8X1 25) 10 CAD	11500760
32.	D9	0.775	CYLINDER, CLU MAS	10079730

2P00-010

33. **0.977** **SCREW, SEMS HEX W/FL WA (M6 3X1 81X20)8010M PZOR**
34. **N20** **4.681** **BRACKET, FRT BRK HOSE**

22527475
10024445

NOTE 1 SEE GROUP 0 000 ART #2P00 010 FOR PEDAL DETAILS
NOTE 2 COMPONENT PARTS SERVICED SEPARATELY

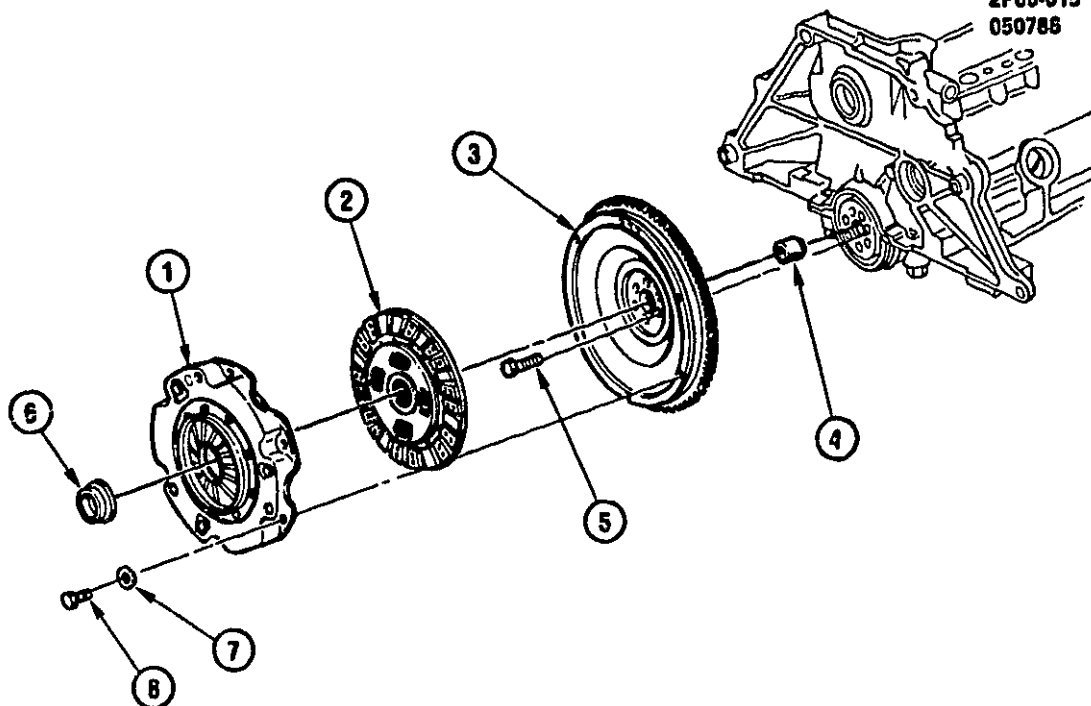

2P00-015

1984-1988 P CLUTCH COVER & PLATE

1.	D9	0.859	COVER, CLU-W/PLT (1984 2 5R)	14085590
	D9	0.859	COVER, CLU-W/PLT (1985-88 2 5R)	14091981
	D9	0.859	COVER, CLU-W/PLT (1985-86 2 8-9)	14087221
	D9	0.859	COVER, W/PLT CLU PRESS (1986-88 2 8-9 W/M T)	14105885
2.	D9	0.886	PLATE, CLU DRIVEN (1984 2 5R)	10117771
	D9	0.886	PLATE, CLU DRIVEN (14 SPLINES)(1985-88 2 5R)	14091982
	D9	0.886	PLATE, CLU DRIVEN (14 SPLINES)(1985-86 2 8-9)	10117771
	D9	0.886	PLATE, CLU DRIVEN (1986-88 2 8-9 W/M T)	14073784
3.	D9	0.666	FLYWHEEL, ENG (2 5R)	10044408
	D9	0.666	FLYWHEEL, ENG (2 8-9)(1984-87)	476575
	D9	0.666	FLYWHEEL (1988)(2 8-9)	14100554
4.	D9	0.649	INSERT, CR/SHF-W/2 5R	10009785
5.	D9	0.669	BOLT, FLYWHL-W/2 5R (M10X1 5X23)	10004357
	D9	0.669	BOLT, FLYWHL-W/2 8-9 (M10X1X23) 10 9 PC	476576
6.	D9	0.799	BEARING, CLU REL (M17 M19.MY8)	14091988
	D9	0.799	BEARING, CLU REL (1985-86 MT2)	94133417
	D9	0.799	BEARING, CLU REL (1986-88 MG2)	14080591
7.		8.931	WASHER, SPRG LK (5/16") PL	9439511
8.		8.900	BOLT, HEX (M8X1 25X20) 10 9 PZOR	11508607

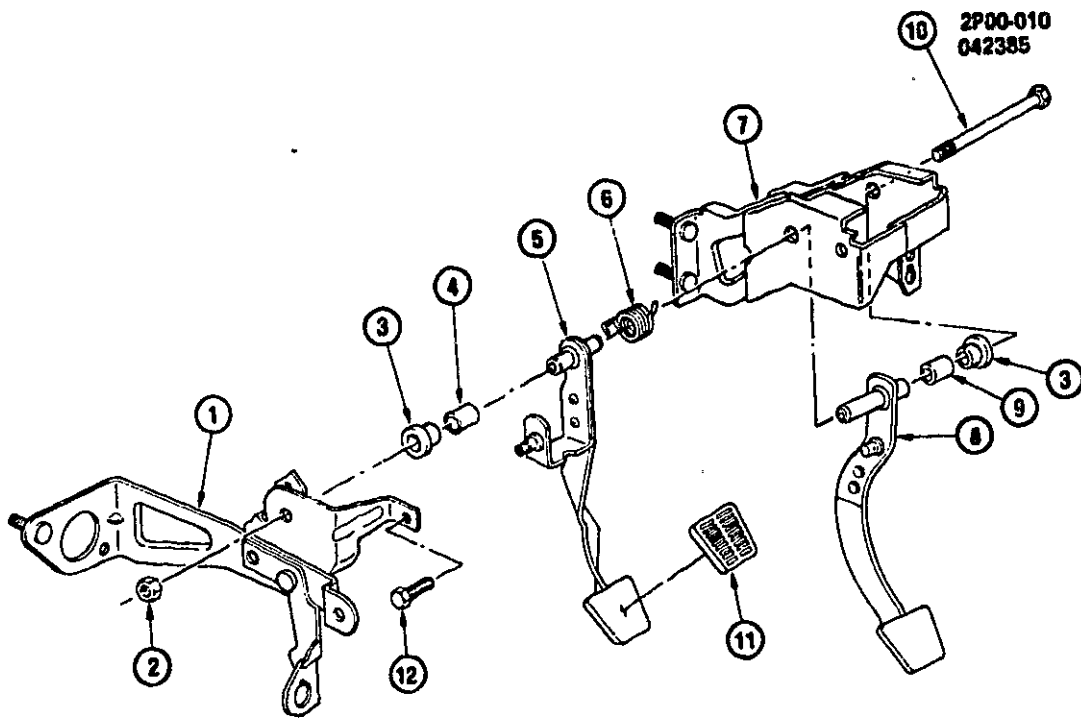

2P00-010

1984-1987 P CLUTCH & BRAKE PEDAL PARTS

1.	D9	0.829	SUPPORT, CLU PED (1984-85)	10036579
	D9	0.829	SUPPORT, CLU PED (1986 W/MT2.M17)(1ST DES)	10036579
	D9	0.829	SUPPORT, CLU PED (1986 W/MT2.M17)(2ND DES)	14105679
	D9	0.829	SUPPORT, CLU PED (1986 W/MG2)	14105679
	D9	0.829	SUPPORT, CLU PED (1987 W/MG2.MT2.M17)	14105679
2.		8.917	NUT, HEX PREV TO (M10X1.5) 10 CAD	11501033
3.	D9	0.844	SLEEVE, CLU PED RTN SPR	10036565
4.	D9	0.832	SPACER, CLU PED PIV	10036577
5.	D9	0.830	PEDAL, CLU (1984-85)	10066423
		N.S.	PEDAL, CLU (1986 W/MT2.M17)(1ST DES)	
	D9	0.830	PEDAL, CLU (1986 W/MT2.M17)(2ND DES)	10066423
	D9	0.830	PEDAL, CLU (1986 W/MT2.M17)(2ND DES)	10066423
	D9	0.830	PEDAL, CLU (1986 W/MT2.M17)(2ND DES)	10066423
6.	D9	0.844	SPRING, CLU PED RET	10036578
7.	N20	4.634	BRACKET, BRAKE PEDAL	10036554
8.	N20	4.625	PEDAL, BRK-W/M.T	10137317
9.	N20	4.626	SPACER, BRK PED PIV	10036567
10.		8.900	BOLT, HEX (M10X1.5X2)	
11.	N20	4.630	COVER, PED PAD	14009148
12.		8.900	BOLT, HFH (M8X1.25X20)	11502693

2P00-021
042387

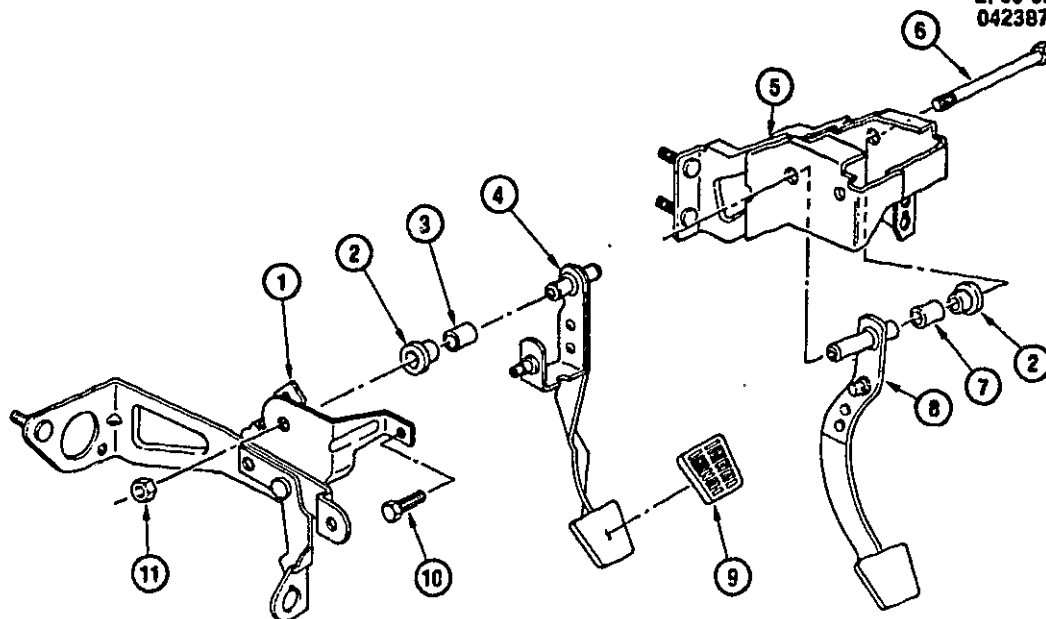

2P00-021

1988 P CLUTCH & BRAKE PEDAL PARTS

1.	D9	0.829	SUPPORT, CLU PED	14105679
2.	D9	0.831	BUSHING, CLU PED	15594358
3.	N20	4.626	SPACER, BRK PED PIV	10035667
4.	D9	0.830	PEDAL, CLU (1986 W/MT2.M17K2ND DES)	10066423
5.	N20	4.634	BRACKET, BRK PED SUPT	10035654
6.		8.900	BOLT, HEX (M10X1 5X7)	
7.	N20	4.626	SPACER, BRK PED PIV	10035667
8.	N20	4.625	PEDAL, BRK	10047605
9.	N20	4.630	COVER, BRK PED PAD (W/M T)	14009148
	N20	4.630	COVER, BRK PED (W/A T)	1258203
10.		8.900	BOLT, HFH (M8X1 25X20) 10 9 POR	11514343
11.		8.917	NUT, HEX PREV TQ (M10X1 5) 10 CAD	11501033

	PONTIAC CHASSIS GROUP 1.000	
--	--	--

ILLUSTRATION INDEX

TITLE	GRID
1984 P GRILLE/RADIATOR (EXC Y82)	J4
1985 P GRILLE/RADIATOR (EXC WU2)	J4
1988 P37 GRILLE/RADIATOR	J4
1985-1988 P ENGINE COOLING SYSTEM-2.8L V6 (2.8-9/L44)	J5
1984-1986 P ENGINE COOLANT FAN-2.5L L4 (LR8/2.5R)(W/C41)	J6
1984-1987 P ENGINE COOLANT FAN-2.5L L4 (LR8/2.5R)(W/C60)	J7
1988 P ENGINE COOLANT FAN-2.5L L4 (LR8/2.5R)(W/C60)	J8
1984-1987 P HOSES & PIPES/RADIATOR-2.5L L4 (LR8/2.5R)	J10
1985-1988 P HOSES & PIPES/RADIATOR-2.8L V6 (L44/2.8-9)	J12
1988 P HOSES & PIPES/RADIATOR-2.5L L4 (LR8/2.5R)	J14

DO NOT MAKE COPIES OF THIS CD

CREATED 04-24-2003

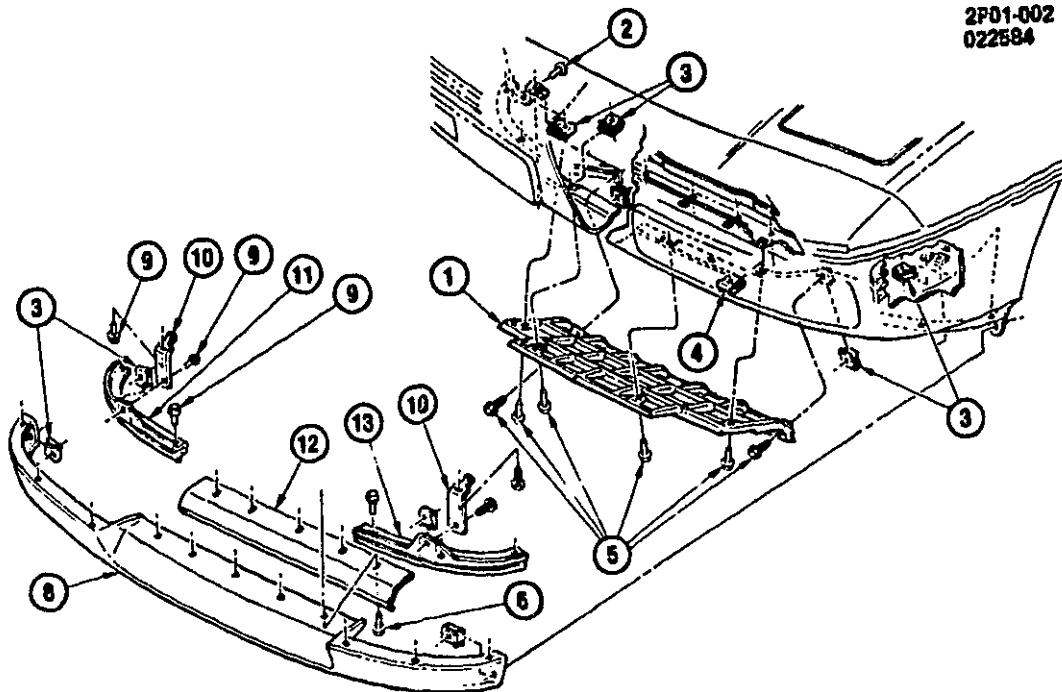

2P01-002

**1984 P GRILLE/RADIATOR (EXC Y82)
1985 P GRILLE/RADIATOR (EXC WU2)
1986 P37 GRILLE/RADIATOR**

1.	E12	1.266	GRILLE, RAD	10029970
2.		8.977	SCREW, HEX TAP W/WA (M4 2X1 41X16) POR	10021798
3.		8.921	NUT, U (#8-18)	
4.		8.921	NUT, SPR (M6X1)	
5.		8.977	SCREW, PAN HL TORX (M4 2X1 41X20)	
6.		8.900	SCREW, HWH (M6X1X20)	
8.	N24	7.833	DEFLECTOR, F/END PNL	10031517
9.		8.977	SCREW, HWH TAP (M4 2X1 41X20)	
10.	N24	7.833	BRACKET, F/END PNL	10021934
11.	E12	1.269	RETAINER, F/END PNL-RH	10021935
12.	E12	1.263	REINFORCEMENT, F/END PNL DFL UPR & LWR	10031518
13.	E12	1.269	RETAINER, F/END PNL-LH	10021936

2P01-006
052086

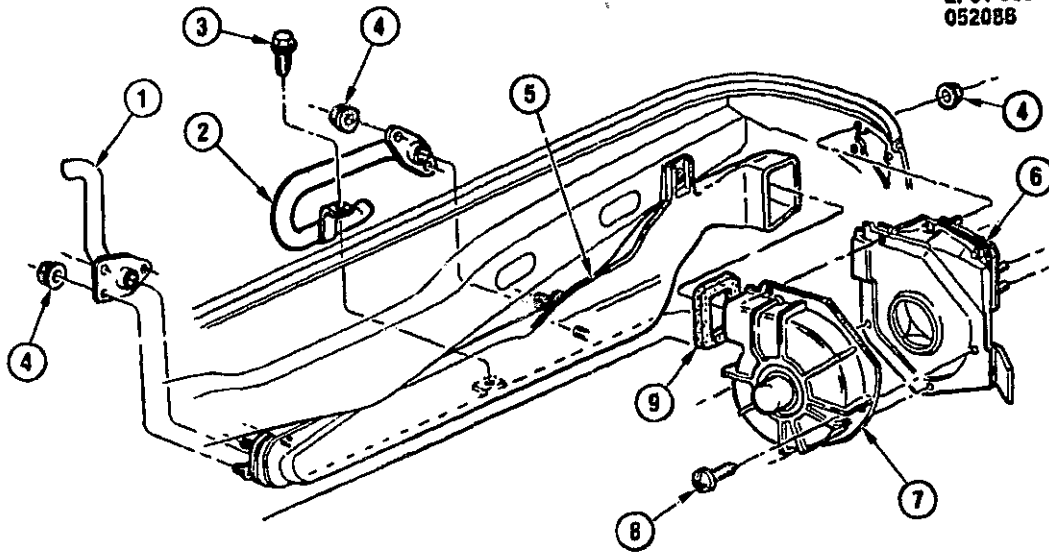

2P01-006

1985-1988 P ENGINE COOLING SYSTEM-2.8L V6 (2.8-9/L44)

1.	E6	1.020	PIPE, ENG CLG AIR (OTLT)-LH	10040831
2.	E6	1.020	PIPE, ENG CLG AIR (OTLT)-RH	10040830
3.		8.977	SCREW,	
4.		8.915	NUT, HFH-W/NYLON INSERT (M6X1) 9 PEO	11508382
5.	E6	1.020	DUCT, ENG COMPT AIR OTLT	20808001
6.	E6	1.020	DUCT, BLO AIR INLET	20808006
	N26	9.277	RELAY, HTR HI BLO (3 140)	10026663
7.		N.S.	BLOWER ASM, ELEC COOLING	
	F17	2.272	CASE, ELEC COOL BLOWER	3090328
	E6	1.015	MOTOR, ELEC COOL (1985)	22083239
	E6	1.015	MOTOR, ELEC COOL (1986-87)	22083239
	E6	1.015	FAN, MTR COOL	3090327
	E6	1.015	GASKET, MT MTR (1985-86)	3090326
	E6	1.015	NUT, BLO FAN(8 857)	3042351
8.		8.977	SCREW, HEX WA HD C/R TAP (M4 2X1.41X20) POR	22536997
9.		N.S.	GASKET, FAN TO DUCT	

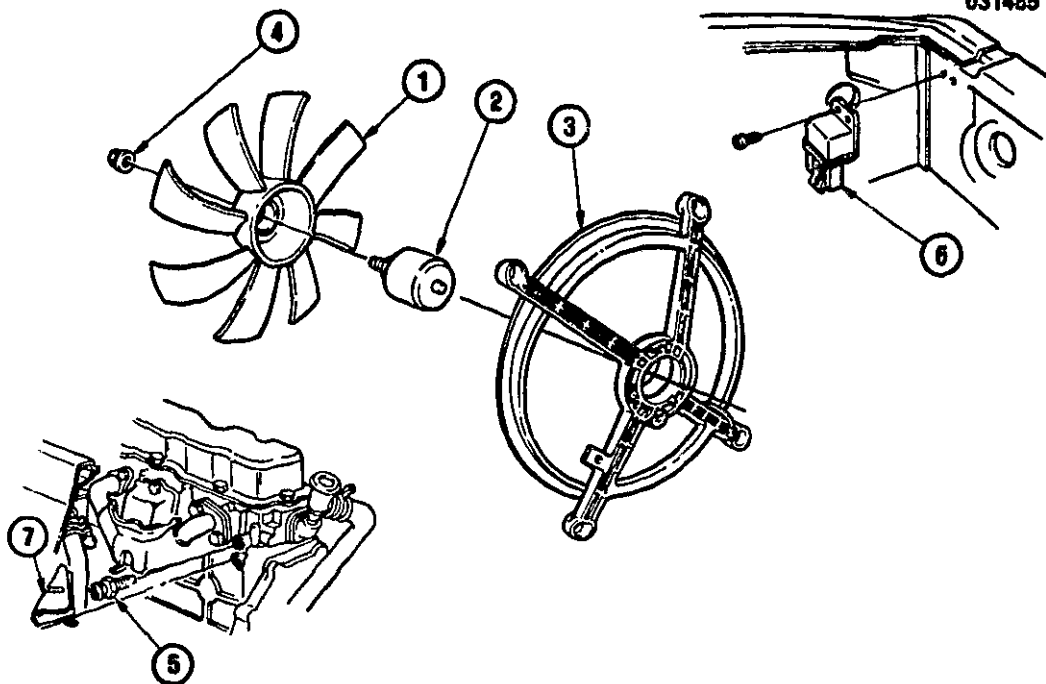

2P01-003

1984-1986 P ENGINE COOLANT FAN-2.5L L4 (LR8/2.5R)(W/C41)

1.	E6	1.055	FAN KIT, ENG CLG (1984-85)	22016879
2.	E6	1.055	MOTOR KIT, ELEC CLG (1984)	22035558
3.	E6	1.055	BRACKET KIT, MTR (1984)	22040853
4.	E6	1.055	NUT, CLG FAN	22049535
5.	E6	1.055	SWITCH, FAN CONT	3040874
6.	E6	1.055	RELAY, FAN (1984)	14078902
	E6	1.055	RELAY, FAN (1985-86)	10038311
7.	E7	1.080	SHIELD, ENG COOL TEMP FAN CONT SW	10032484

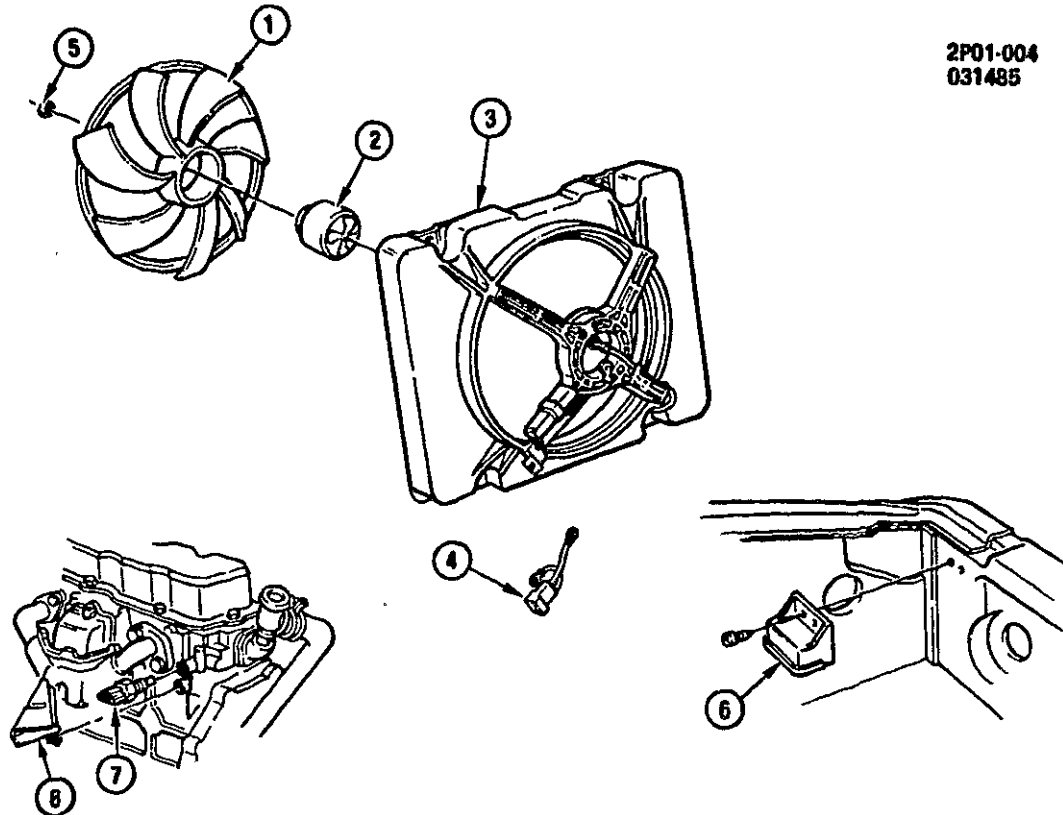

2P01-004

1984-1987 P ENGINE COOLANT FAN-2.5L L4 (LR8/2.5R)(W/C60)

1.	E6	1.055	FAN KIT, ELECT CLG (1984 C60)	22040856
	E6	1.055	FAN KIT, ELEC CLG (1985-87 C60 EXC V08)	22098793
	E6	1.055	FAN KIT, ELEC CLG (1985-87 C60.V08)	22040856
2.	E6	1.055	MOTOR KIT, FAN (1984 C60)	22082546
	E6	1.055	MOTOR KIT, FAN (1985-87 C60 EXC V08)	22074968
	E6	1.055	MOTOR KIT, FAN (1985 C60.V08)	22082546
3.	E6	1.055	SHROUD KIT, FAN (1984 C60)	22040854
	E6	1.055	SHROUD KIT, FAN (1985-87 C60.V08)	22049524
	E6	1.055	SHROUD KIT, FAN (1985-87 C60 EXC V08)	22049521
4.	E6	1.055	RESISTOR KIT, FAN MTR (1984 C60)	22040855
	E6	1.055	RESISTOR KIT, ELEC CLG (1985-87 C60.V08)	22049799
5.	E6	1.055	NUT, ELEC CLG FAN	22049536
6.	E6	1.055	RELAY, FAN MTR (W/C60.V08)(1984-87)	10040131
	E6	1.055	RELAY, ENG COOL FAN (W/C60.EXC V08)(1985-87)	10038311
7.	E6	1.055	SWITCH, COOLANT TEMP	3050223
8.	E7	1.060	SHIELD, ENG COOL TEMP FAN CONT SW	10032484

2P01-007
050787

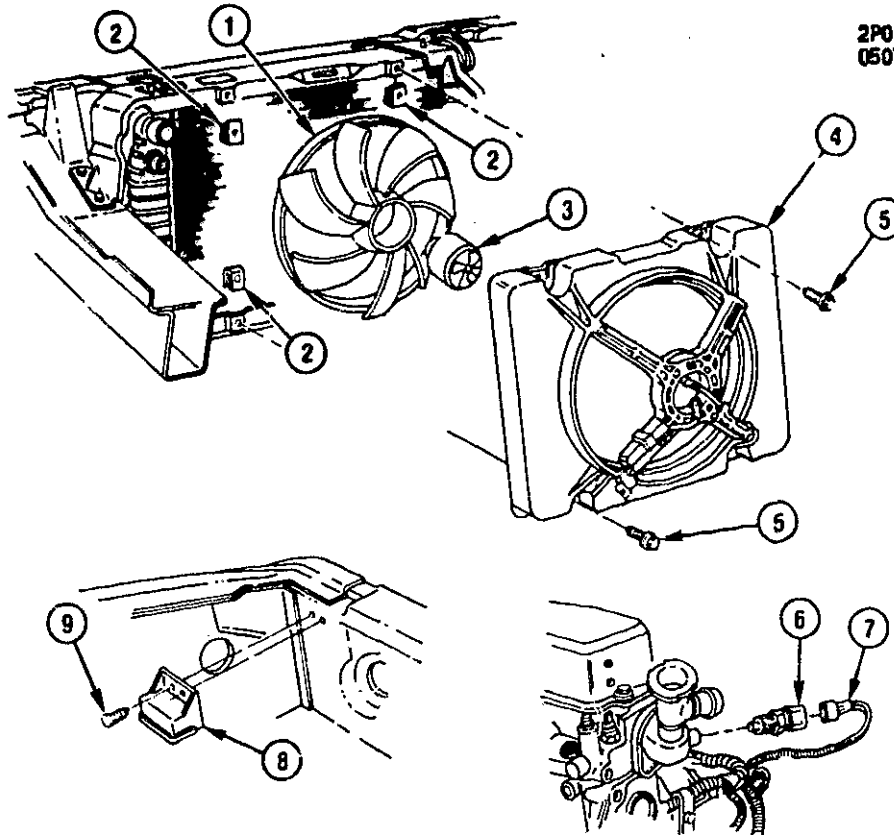

2P01-007

1988 P ENGINE COOLANT FAN-2.5L L4 (LR8/2.5R)(W/C60)

1.	E6	1.055	FAN KIT, ELEC CLG
2.	E6	8.921	NUT, U-SHAPE MULTI THRD SPG (M6X1X6 3)
3.	E6	1.055	MOTOR KIT, ELEC CLG FAN
4.	E13	1.277	SHROUD KIT, ELEC CLG FAN
5.		8.900	SCREW, HEX W/CON WA (M6X1X20)
6.	N15	3.882	SENSOR, CLNT TEMP (ECM) (1 150)
7.	G4	2.525	HARNESS, ENG WRG
8.	E6	1.055	RELAY, ENG COOL FAN (2 STAGE FAN)(V08)
9.		8.977	SCREW, HWH (M4 2X1 41X13ZPHTAPTIZE THD)

22098793
11513918
22074988
22049521
11514383
25036979
12078788
10040131
22508732

2P01-001
052786

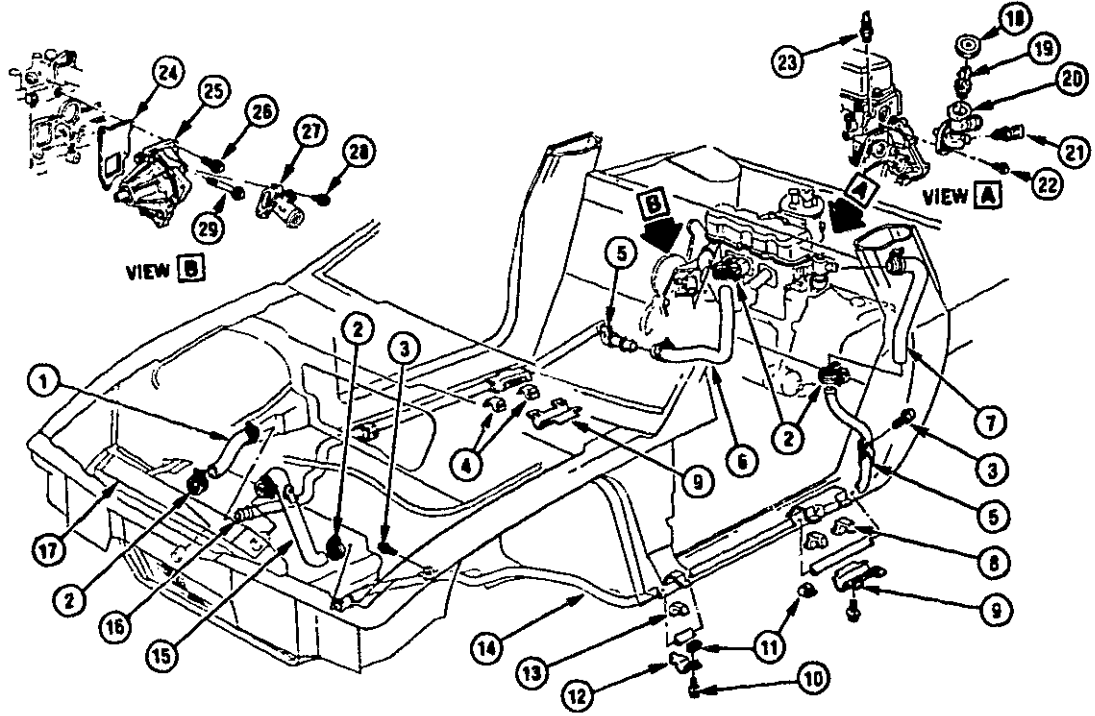

2P01-001

1984-1987 P HOSES & PIPES/RADIATOR-2.5L L4 (LR8/2.5R)

1.	E10	1.173	HOSE, RAD OTLT-FRT (1984-87)	10024909
2.	E10	1.166	CLAMP, HOSE (33 3 TO 57 2MM)	22518866
3.		8.977	BOLT, HWH TAP (M6 3X1 81X16)	12337828
4.	E9	1.159	INSULATOR, RAD OTLT RR TO RH BRAKE PIPE (1 159)	10029873
5.	E10	1.166	CLIP, RAD INL & OTLT PIPE-RR	427047
6.	E10	1.173	HOSE, RAD OTLT-RR (1984)	10026986
	E10	1.173	HOSE, RAD OTLT RR (1985-87)	10040838
7.	E9	1.159	HOSE, RAD INL-RR (1984)	10027046
	E9	1.159	HOSE, RAD INL-RR (1985-87)	10042610
8.	E9	1.159	INSULATOR, RAD INL PIPE-RR	10029873
9.	E10	1.166	CLAMP, RAD INL & OTLT PIPE INSUL-RR	10029872
10.		8.977	BOLT, HEX WA HD TAP (M6 3X1 81X20)	12337828
11.		8.921	NUT, TYPE P-WU SPR (M6 3X1 81)	11514290
12.	E10	1.166	CLAMP, RAD INL & OTLT PIPE INSUL-FRT (1984)	10023347
	E10	1.166	CLAMP, RAD INL & OTLT PIPE INSUL-FRT (1985-87)	10023347
13.	E10	1.166	INSULATOR, RAD INL & OTLT PIPE-FRT	10023372
14.	E9	1.159	PIPE, RAD INL (1984)	10034666
	E9	1.159	PIPE, RAD INL FRT-LH (1985-87)	10033668
	E9	1.159	PIPE, RAD INL-LH (1984)	10034666
	E9	1.159	PIPE, RAD INL-FRT (1985-87)	10033668
15.	E9	1.159	HOSE, RAD INL-FRT	10024723
16.	E10	1.173	PIPE, RAD OTLT-RH (1984)	10034667
	E10	1.173	PIPE, RAD OTLT-RH (1985-86)	10039767
	E10	1.173	PIPE, RAD OTLT-RH (1987)	14101682
17.	E10	1.219	RADIATOR, ENG (1984)	3057621
	E10	1.219	RADIATOR, ENG (1985 EXC V08.WS9)	3057621
	E10	1.219	RADIATOR, ENG (1985-86 W/MD9.C60.V08)	3057621
	E10	1.219	RADIATOR, ENG (1986 W/MD9 EXC C60.V08)	3057621
	E10	1.219	RADIATOR, ENG (1986 W/MT2)	3057621
	E10	1.203	CAP, RAD FIL	10036879
18.	E12	1.251	CAP, THERM HSG (TYPE #RC40)	6410941
19.	E12	1.246	THERMOSTAT, (195 DEG)(1984EXC WS9)	3059793
	E12	1.246	THERMOSTAT, (180 DEG)(1984 WS9)	3059909
	E12	1.246	THERMOSTAT, (195 DEG)(1985-87)	3059793
20.	E12	1.251	HOUSING, THERM	10038440
21.	N15	3.682	SENSOR, CLNT TEMP (1984)	10045847
	N15	3.682	SENSOR, CLNT TEMP (ECM) (1 150)	25036979
22.		8.900	BOLT, HFH (M8X1 25X16) 9 8 PC	11507022
23.	E9	1.150	SENSOR, CLNT TEMP GA (1984)	25036828
	E9	1.150	SENSOR, CLNT TEMP GA/HOT LT	25036809
24.	E9	1.079	GASKET, CLNT PUMP	10124640
25.	E9	1.069	PUMP, CLNT	10169526
26.		8.900	BOLT, HWH (M10X1 5X25) 10 9 PH	11502788
27.	E9	1.073	INLET, CLNT PUMP (1984-86)	10037949
	E9	1.073	INLET, CLNT PUMP (1987)	10042097
28.		8.900	BOLT,HWH (M8X1 25X25) 9 8 PC	11502687
29.		8.900	BOLT, HEX (M10X1 5X110) 10 9 PC	11504309

2P01-005
052987

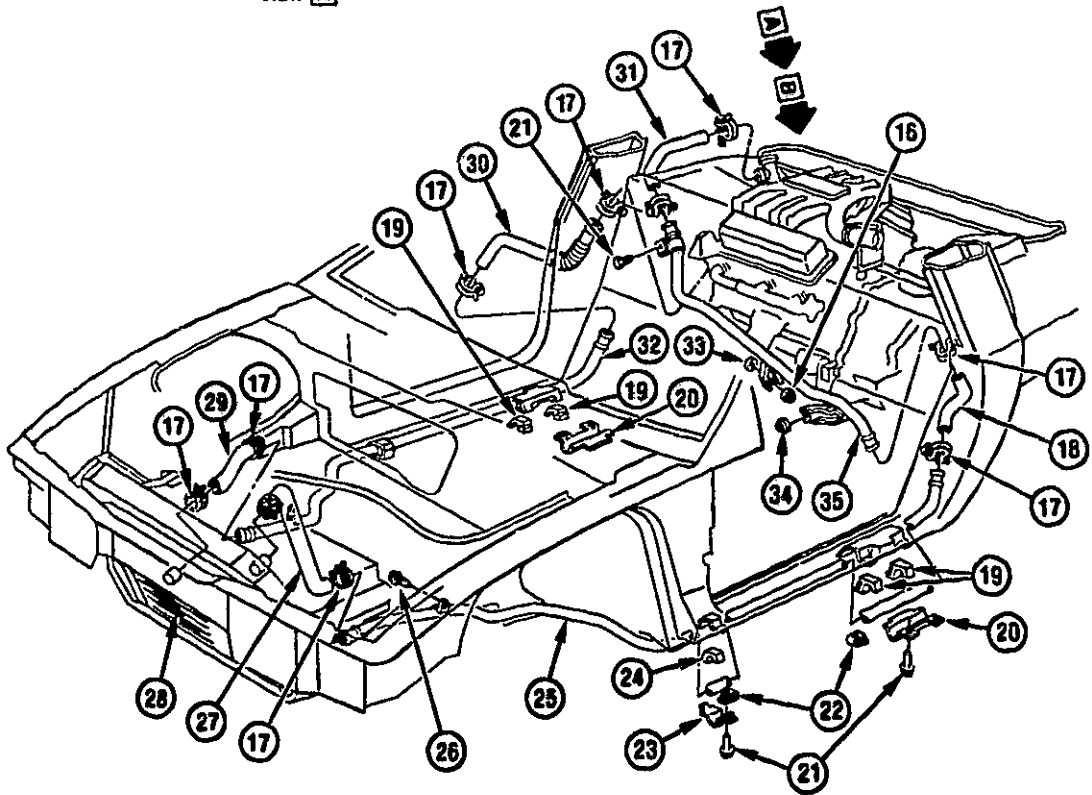
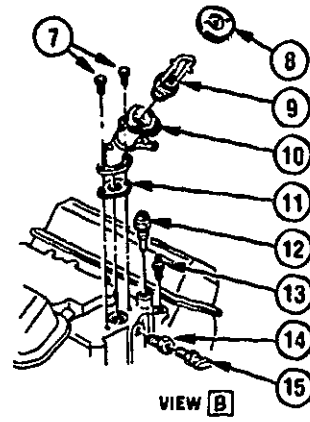
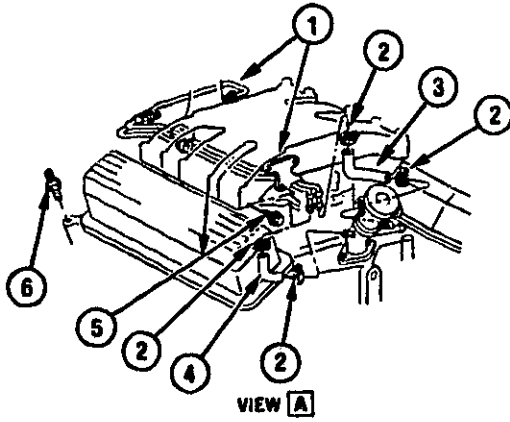

2P01-005

1985-1988 P HOSES & PIPES/RADIATOR-2.8L V6 (L44/2.8 9)

1.	N11	3.337	PIPE, THROT BODY CLNT SUPPLY & RTN	10040107
2.		8.948	CLAMP, WORM GEAR HEX SLOT SCREW (250 X 625) SS	25518880
3.	N11	3.337	HOSE, THROT BODY HTR OTLT PIPE CLNT	10030781
4.	N11	3.337	HOSE, THROT BODY HTR INL PIPE CLNT	10030780
5.		8.900	BOLT, HFH (M6X1X20) 9 8 PZOR	11508800
6.	E9	1.150	SENSOR, CLNT TEMP	25038809
7.		8.900	BOLT, HEX (M8X1 25X20) 10 9 PZOR	11508887
8.	E12	1.251	CAP, THERM HSG (TYPE #RC40)	6410941
9.	E12	1.248	THERMOSTAT, CLNT OTLT (195 DEG)	3059793
10.	E12	1.251	HOUSING, THERMO	10040122
11.	E9	1.154	GASKET, THERM HSG	14079715
12.	N11	3.329	SWITCH, COLD START F/INJ	14084318
13.	E8	1.055	SWITCH, FAN CONT	3040874
14.	E9	1.150	BUSHING, CLNT TEMP GA SENSOR	10037037
15.	N15	3.682	SENSOR, CLNT TEMP (ECM) (1 150)	25038979
16.		8.917	NUT, HFH (M10X1 5X10) POR 10	11508101
17.	E10	1.166	CLAMP, HOSE (33 3 TO 57 2MM)	22518888
18.	E9	1.159	HOSE, RAD INL INTER (1985-87)	10041086
		N.S.	HOSE, RAD INL INTER (1988)	
19.	E9	1.159	INSULATOR, RAD INL PIPE RR	10029873
20.	E10	1.166	CLAMP, RAD PIPE INL RR	10029872
21.		8.977	BOLT, SEMS HWH (M6 3X1 81X20)PZOR	22527475
22.		8.921	NUT, U-TYPE (M6 3X1 81)PZOR	11509582
23.	E10	1.166	CLAMP, RAD PIPE FRT	10023347
24.	E10	1.166	INSULATOR, RAD PIPE FRT	10023372
25.	E9	1.159	PIPE, RAD INL FRT-LH	10035581
26.		8.977	BOLT, HWH TAP (M6 3X1 81X16) POR	22527475
27.	E9	1.159	HOSE, RAD INL FRT (1985-87)	10024723
	E9	1.159	HOSE, RAD INL FRT (1988)	10080278
28.	E10	1.219	RADIATOR, ENG(*1)	3057621
	E10	1.203	CAP, RAD FIL	10038879
29.	E10	1.173	HOSE, RAD OTLT FRT (1985-87)	10024909
	E10	1.173	HOSE, RAD OTLT FRT (1988)	10052300
30.	E10	1.173	HOSE, RAD OTLT RR (1985-87)	10038860
	E10	1.173	HOSE, RAD OTLT RR (1988)	10120079
31.	E9	1.159	HOSE, RAD INL RR	10032771
32.	E10	1.173	PIPE, RAD OTLT (1985-86)	10039787
	E10	1.173	PIPE, RAD OTLT (1988)	10052298
	E10	1.173	PIPE, RAD OTLT (1987)	14101682
33.		8.929	WASHER, FL (15/32X15/16X1/16) ZC	120395
34.		8.917	NUT, HEX TORQ PREV (M8X1 25) 10 CAD	11500780
35.	E9	1.159	PIPE, RAD INL RR (W/M T)(1985-87)	10041735
	E9	1.159	PIPE, RAD INL RR (W/A T)(1985-87)	10041189
	E9	1.159	PIPE, RAD INL RR (W/M T)(1988)	10110419
	E9	1.159	PIPE, RAD INL RR (W/A T)(1988)	10110418

NOTE 1 SEE CHART IN GROUP FOR USAGE

2P01-008
022688

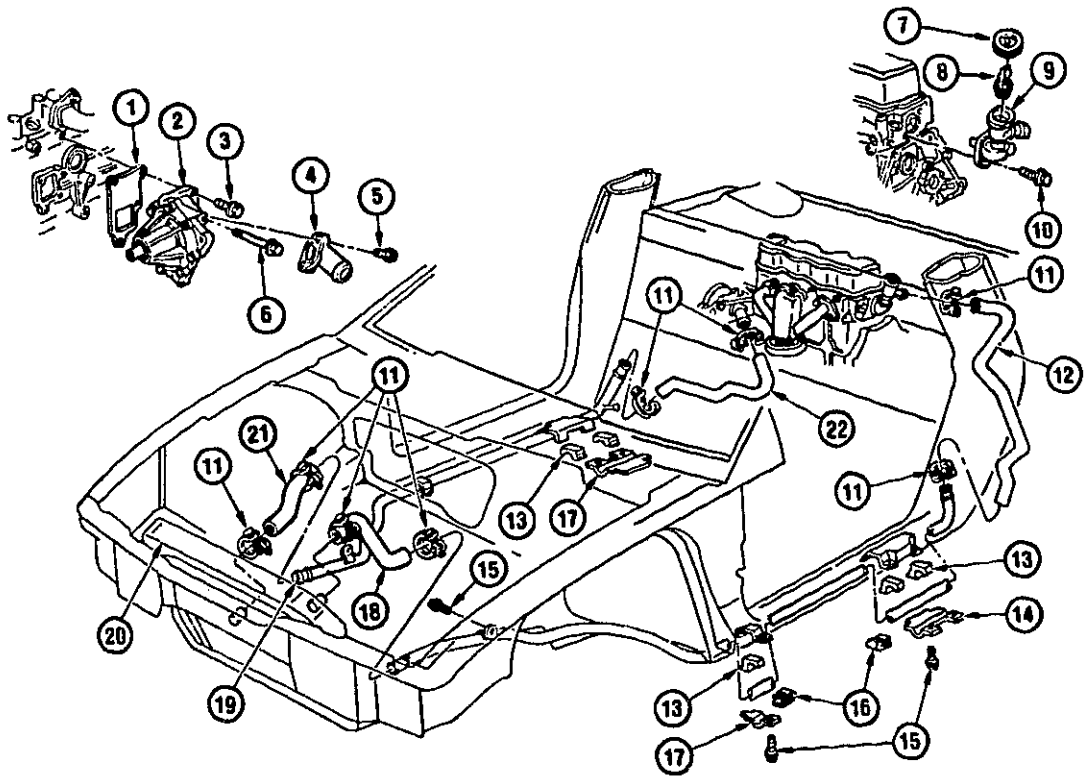

2P01-008

1988 P HOSES & PIPES/RADIATOR-2.5L L4 (LR8/2.5R)

1.	E9	1.079	GASKET, CLNT PLMP	10124640
2.	E9	1.069	PUMP, W/SHF. BRG. SEAL & TURBINE WTR PMP	10159528
3.		8.900	BOLT, HWH (M10-1 5X25)10 9 PH	11502788
4.	E9	1.073	INLET, CLNT PUMP	10042097
5.		8.900	BOLT, HEX W/CON WA (M8X1 25X25)9 8 POR	11508764
6.		8.900	BOLT, HEX (M10X1 5X110)10 9 PC	11504309
7.	E12	1.251	CAP, THERM HSG (TYPE #RC40)	8410941
8.	E12	1.246	THERMOSTAT, ENG CLNT OTLT (195 DEGREE)	3059793
9.	E12	1.251	HOUSING, THERM	10038440
10		8.900	BOLT, HEX FLGD (M8X1 25X16)9 8 PC	11507022
1	E10	1.166	CLAMP, HEX HD WORM (33 3 TO 57 2M)	22518666
1.	E9	1.159	HOSE, RAD INL	
13.	E9	1.159	INSULATOR, RAD INL PIPE (RR)	10029873
14.	E10	1.166	CLAMP, RAD PIPE (OTLT)(RR)	10029872
15.		8.977	BOLT, SEMS HEX W/FL WA (M6 3X1 81X20)6010M PZOR	12337828
16.		8.921	NUT, TYPE P-WU SPR (M6 3X1 81)PHOS ORG	11514290
17.	E10	1.166	CLAMP, RAD PIPE INSL (INL/OTLT)(FRT)	10023347
18.	E9	1.159	HOSE, RAD INL (FRT)	10080278
19.	E10	1.173	PIPE, RAD (OTLT)	10052298
20.	E10	1.219	RADIATOR (CODES MB,MX,MC,MY)	3057621
21.	E10	1.173	HOSE, RAD OTLT (FRT)	10052300
22.	E10	1.173	HOSE, RAD OTLT	10080290

PONTIAC CHASSIS GROUP 2.000

ILLUSTRATION INDEX

TITLE	GRID
1984-1988 P STARTER MOTOR (DELCO REMY)	K5
1984-1987 P GENERATOR ASM	K6
1984-1988 P GENERATOR MOUNTING-2.5L L4 (LR8/2.5R)	K8
1985-1987 P GENERATOR MOUNTING-2.8L V6 (L44/2.8-9)	K9
1987-1989 P GENERATOR MOUNTING-2.5L L4 (LR8/2.5R)	K10
1988 P GENERATOR MOUNTING-2.8L V6 (L44/2.8-9)	K11
1984-1988 P DISTRIBUTOR/IGNITION-L4	K12
1985-1988 P DISTRIBUTOR/IGNITION-2.8L V6 (L44/2.8-9)	K13
1987-1989 P COIL & MODULE/IGNITION (LR8/2.5R)(DELCO)	K14
1984-1987 P BATTERY MOUNTING & CABLES	K15
1988 P BATTERY MOUNTING & CABLES	K16
1984-1988 P LAMPS/FRONT	K18
1984-1988 P TURN SIGNAL LEVER & RELAYS	K20
1984-1985 P LAMPS/REAR	K21
1986-1988 PG97 LAMPS/REAR	K22
1986-1988 PM37 LAMPS/REAR	K23

GM02-066
032989

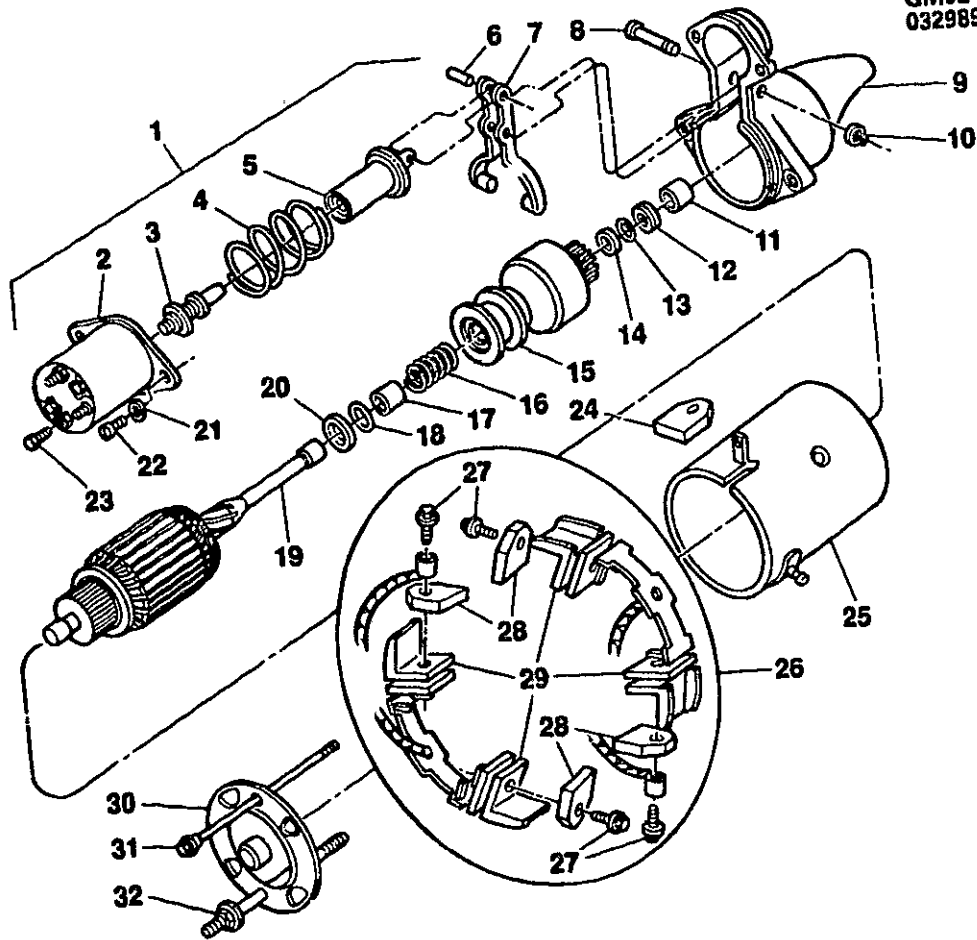

GM02-0865

1984-1988 P STARTER MOTOR (DELCO REMY)

1.	F7	2.041	MOTOR, (1984-85 2.5R)(1985 2.8-9)(1987)(1ST DES 1988)	10455023
	F7	2.041	MOTOR, (1988 2ND DESIGN)	10455023
2.	F13	2.100	SWITCH, SOL(*1)	1114531
	F13	2.100	SWITCH, SOL(*2,3,4,5)	1114566
3.	F13	2.102	CONTACT, W/PUSH ROD.SOL	1978337
4.	F13	2.108	SPRING, PLUNGER RETURN	1958879
5.	F14	2.113	PLUNGER,	1987391
6.	F13	2.108	PIN, PLUNGER ATCH TO SHIFT LVR	1987049
7.	F13	2.108	LEVER, SHIFT	1984501
8.	F13	2.108	SHAFT, SHIFT LEVER	1985804
9.	F13	2.085	HOUSING, DRIVE	1984734
10.		8.934	RING, SNAP (ID7 2-7 0,THK.66-.54)(3AM1)(ZN CHRO)	11505767
11.		N.S.	BUSHING, DRIVE END (NOT REQUIRED)	
12.	F13	2.063	COLLAR, THRUST DRIVE END	1927850
13.	F13	2.063	RING, PINION STOP RET. DRIVE END	1927848
14.	F13	2.063	COLLAR, PINION STOP DRIVE END	1927849
15.	F13	2.088	DRIVE, (INCLUDES 16,17,18)	1984511
16.	F13	2.087	SPRING, MOTOR DRIVE (PART OF 15)	10456420
17.	F13	2.083	BUSHING, DRIVE END (PART OF 15)	1932190
18.	F13	2.108	LOCKWIRE, MOTOR DRIVE (PART OF 15)	1904436
19.	F13	2.043	ARMATURE>(*1)	10498097
	F13	2.043	ARMATURE>(*2,3,4,5)	10495931
20.		N.S.	WASHER, BRAKE C.E(*1)	
21.		8.931	WASHER, SPR LK (26X.489) ZOR	9439510
22.		8.907	SCREW, FILLISTER HD MA (1/4-20X1/2") CAD OR ZN	132255
23.		8.977	SCREW, HEX TAPPING (10-32X.500) TYPE S. CAD	9427815
24.	F13	2.102	GROMMET, FLD FRM (PART OF 25)	1984527
25.	F13	2.049	FRAME, W/FIELD (INCLUDES 24,26)(*1)	10499208
	F13	2.049	FRAME, W/FIELD (INCLUDES 24,26)(*2,3,4,5)	1985143
26.	F13	2.052	HOLDER KIT, BRUSH (INCLUDES 27,28,29)(*1)	10456402
	F13	2.052	HOLDER KIT, BRUSH (INCLUDES 27,28,29)(*2,3,4,5)	10497180
27.		8.977	SCREW, BRUSH ATTACH (PART OF 26)	25023918
28.	F13	2.051	BRUSH, (PART OF 26)	1893296
29.	F13	2.052	HOLDER, BRUSH INSUL (PART OF 26)	1893293
30.	F13	2.067	FRAME, COMMUTATOR END	1978292
31.	F13	2.077	BOLT, THRU(*1)	1985150
32.	F13	2.077	BOLT, W/EXT.THRU	1985622

NOTE 1 SERVICES MOTOR STAMPED 10455023

NOTE 2 SERVICES MOTOR STAMPED 1998533

NOTE 3 SERVICES MOTOR STAMPED 1998503

NOTE 4 SERVICES MOTOR STAMPED 1998504

NOTE 5 SERVICES MOTOR STAMPED 1998429

GM02-030
072382

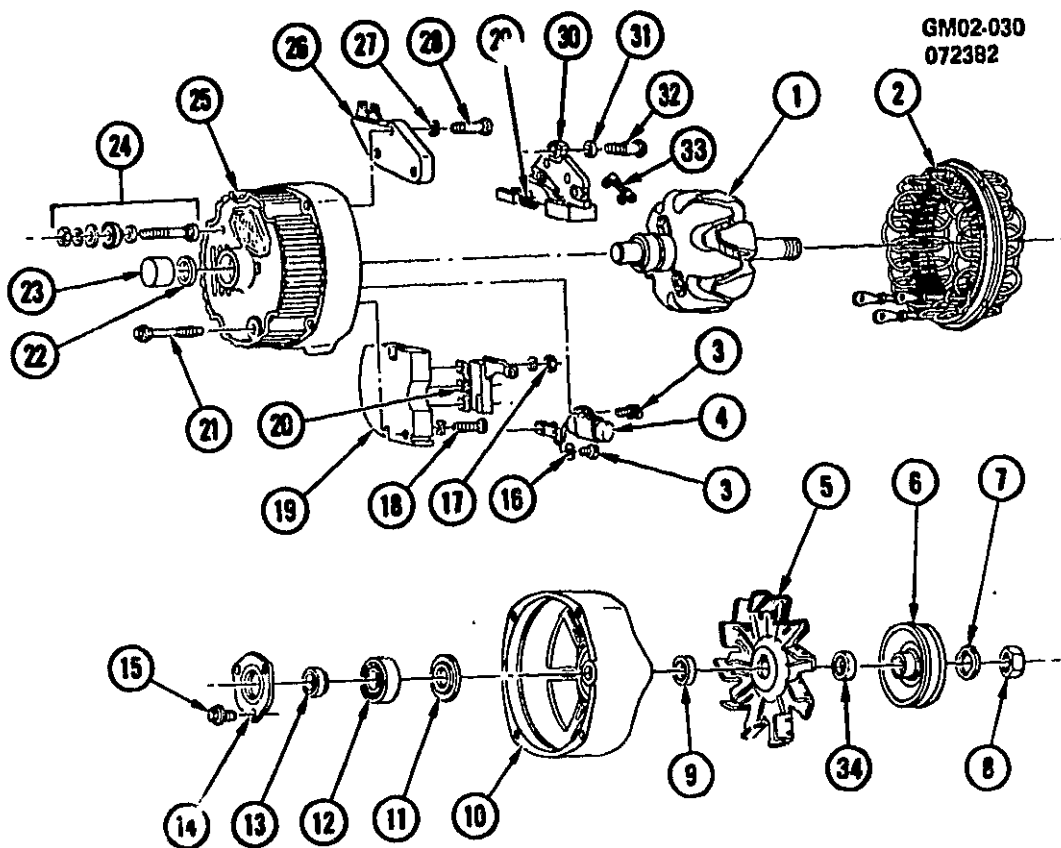

GM02-030

1984-1987 P GENERATOR ASM

1.	F23	2.279	ROTOR, GENERATOR
2.	F23	2.310	STATOR, GENERATOR
3.		8.977	SCREW, (8/32X1/2)
4.	F23	2.319	CAPACITOR,
5.	F17	2.274	FAN, GENERATOR
6.	F17	2.274	PULLEY, GENERATOR
7.	F23	2.280	WASHER, ARM SPRING
8.	F23	2.280	NUT, SHAFT DRIVE END
9.	F23	2.307	COLLAR, SHAFT DRIVE END OUTSIDE
10.	F23	2.305	FRAME, DRIVE END
11.		N.S.	SLINGER, GREASE
12.	F23	2.306	BEARING, DRIVE END
13.	F23	2.307	COLLAR, SHAFT DRIVE END INSIDE
14.	F23	2.307	PLATE, BEARING RETAINER DRIVE END
15.	F23	2.307	SCREW, BEARING RETAINER PLATE
16.		8.929	WASHER,
17.		8.915	NUT, HEX (#8 -32)
		8.915	NUT, RECTIFIER BRIDGE, HEX (8-32Z 284M)
18.	F23	2.319	SCREW, RECTIFIER BRIDGE ATTACHING
19.	F23	2.319	RECTIFIER, BRIDGE
20.	F23	2.319	DIODE, TRIC
21.	F23	2.316	BOLT, THROUGH
22.		N.S.	SEAL, BEARING
23.	F23	2.298	BEARING, SLIP RING END
24.	F23	2.313	TERMINAL, BATTERY
25.	F23	2.297	FRAME, SLIP RING END
26.	G4	2.500	REGULATOR,
27.		8.929	WASHER,
28.	F23	2.291	SCREW, BRUSH HOLDER ATTACHING
29.	F23	2.286	SPRING, BRUSH

30.	F23	2.291	BRUSH, W/HOLDER
31.		8.929	WASHER,
32.	F23	2.291	SCREW, BRUSH HOLDER ATTACHING
33.	F23	2.319	RESISTOR, (REGULATOR TO BRUSH GROUND)
34.	F23	2.307	COLLAR, SHAFT (BETWEEN PULLEY AND FAN)

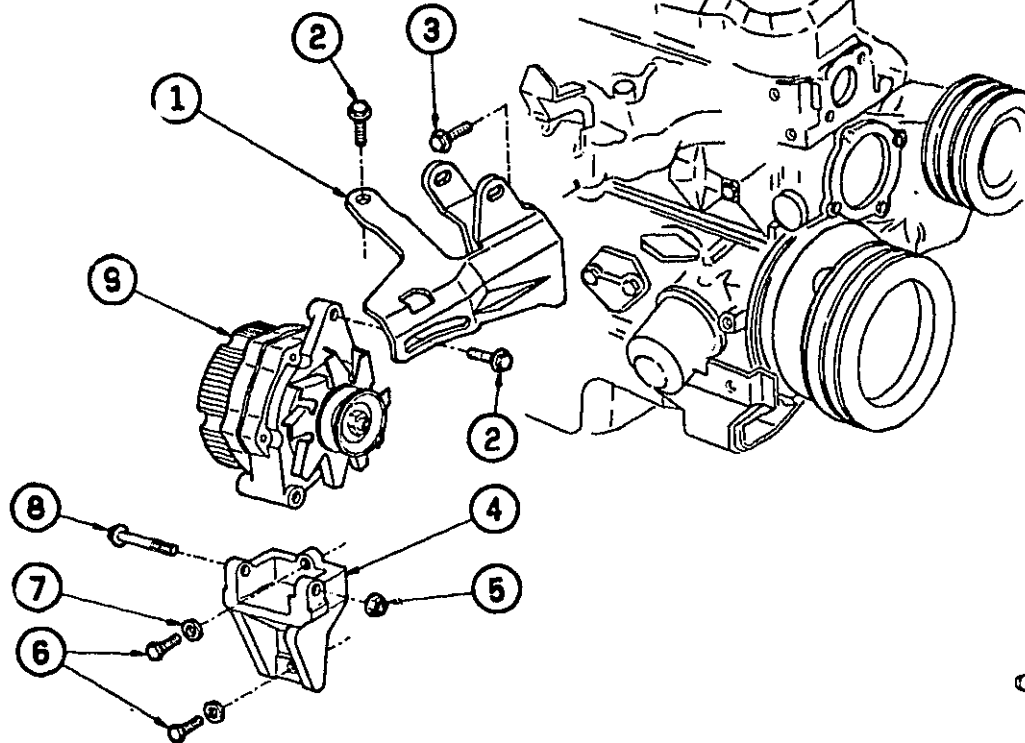

2P02-003

1984-1986 P GENERATOR MOUNTING-2.5L L4 (LR8/2.5R)

1.	F23	2.317	BRACKET, GEN ADJ (1984)	10035803
	F23	2.317	BRACKET, GEN ADJ (1985-86)	10035803
2.	F23	2.277	SCREW, SPL WA HEX HD (M8 X 1 25-6G THD)	
3.	F23	2.277	SCREW, SPL WA HEX HD (M10 X 1 5-6G THD)	
4.	F23	2.277	SUPPORT, GEN	10019484
5.		8.917	NUT, HEX FLG (M10 X 1 5)	11506101
6.		8.900	BOLT, HEX (M10 X 1 5 X 35)	11500931
7.		8.929	WASHER, SPL STL (15/32 IDX1 1/8 ODX1/8)	3790788
8.		8.900	BOLT, FLGD HEX HD (M10X1 5X105)(9 8 PZOR)	11508142
9.	F17	2.275	GENERATOR, (94 AMP)	1101308
	F17	2.275	GENERATOR, (7R AMP)	1101307

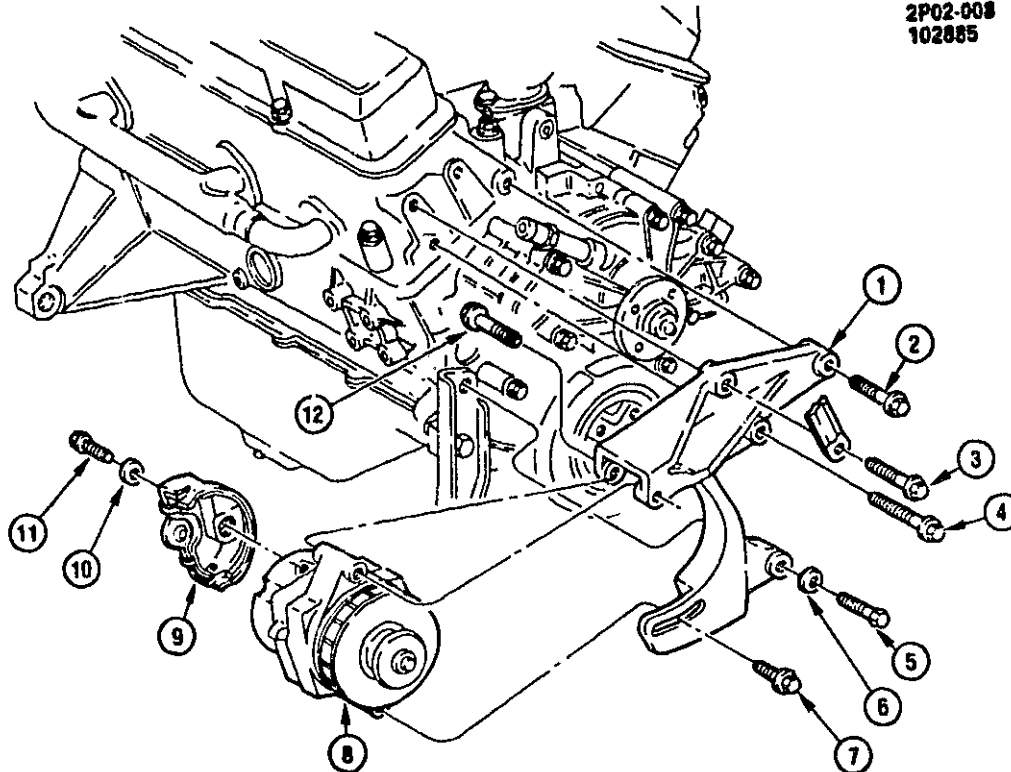

2P02-008

1985-1987 P GENERATOR MOUNTING-2.8L V6 (L44/2.8-9)

1.	F23	2.277	BRACKET, GEN	10044919
2.		8.900	BOLT, HWH (M10X1 5X35 10 9 POR)	14056165
3.		8.900	BOLT, (M10X1 5X40X0 002)	11509844
4.		8.900	BOLT, HFH (M8X1 25X75 9 8 POR)	11508301
5.	D9	0.029	BOLT, ENG MT BRKT	10034667
6.	D9	0.002	WASHER, ENG MT BRKT(TO CYL BLK)	473539
7.		8.977	BOLT, HEX CON TOO FH (M8X1 25X32 9 8 PH)	11501843
8.	F17	2.275	GENERATOR, 94 AMP	1101308
	F17	2.275	GENERATOR, 66 AMP	1101307
9.	F23	2.277	SHIELD, GEN HT	10036230
10.		8.931	WASHER, MET REG HELICAL LK (M8)	9439511
11.		8.900	BOLT, HEX (M8X1 25X16 FULL 9 8,PS)	11509589
12.		8.900	BOLT, HEX FLG HD (M10X1 5X90)(9 8 POR)	11509202

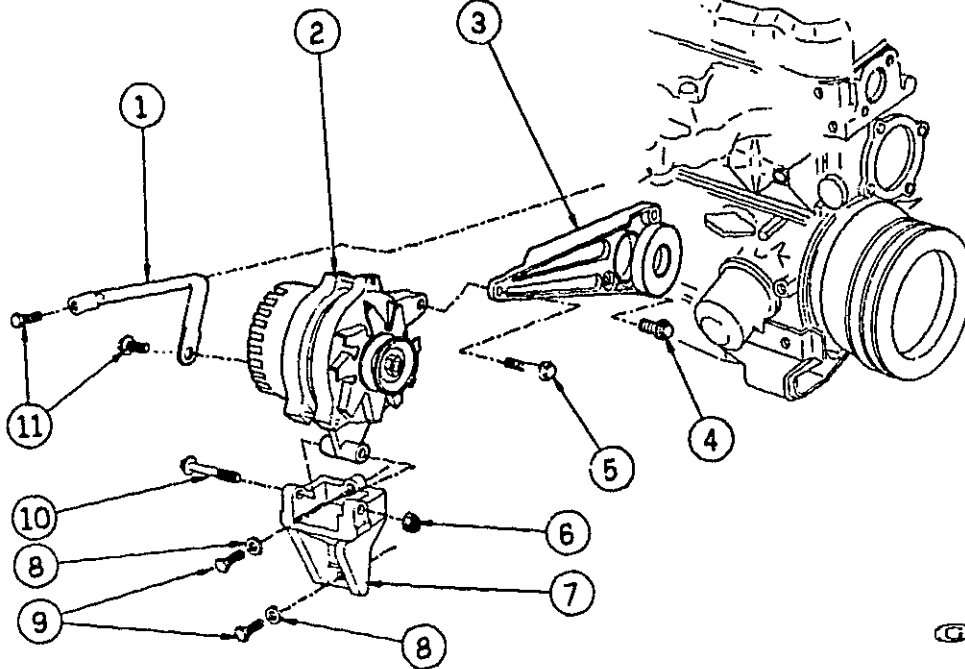

2P02-010

1987-1988 P GENERATOR MOUNTING-2.5L L4 (LR8/2.5R)

1.	F23	2.277	BRACE, GEN RR	10041242
2.	F17	2.275	GENERATOR, (REMAN)(W/85 AMP K99)(1987-88)	10483020
3.	E7	1.080	TENSIONER, DR BELT	10041248
4.		8.900	BOLT, HWH (M10X1 5X35) 10 9 POR	14058165
5.		8.900	BOLT, HEX (M8X1 25X30) 9 8 ZC	11508353
6.		8.917	NUT, HFH (M10X1 5X10) POR 10	11508101
7.	F23	2.277	SUPPORT, GEN	10041241
8.		8.929	WASHER, FL (M10X20X3) CP	10000925
9.		8.900	BOLT, HEX (M10X1 5X35) 10 9 PC	11500931
10.		8.900	BOLT, HEX FLG HD (M10X1 5X90)(9 8 POR)	11509202
11.	F23	2.277	SCREW, SPL WA HEX HD (M8X1 25) 6G THD	10008893

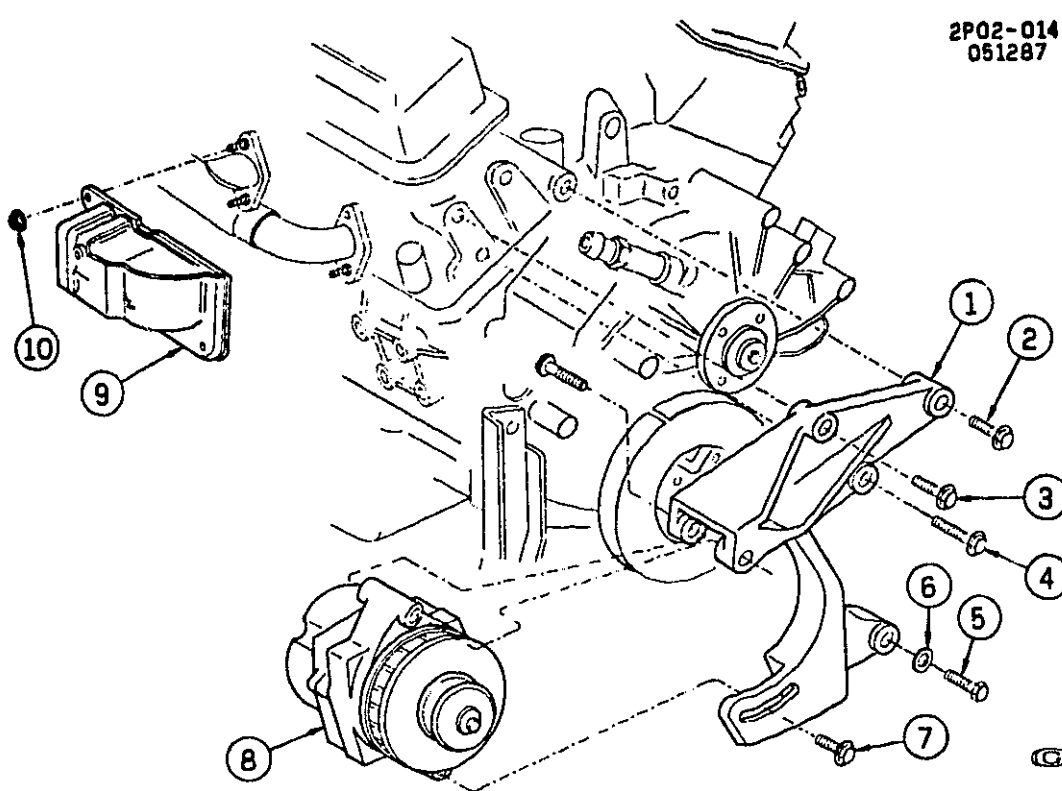

2P02-014

1988 P GENERATOR MOUNTING-2.8L V6 (L44/2.8-9)

1.	F23	2.277	BRACKET, GEN	10044919
2.		8.900	BOLT, HWH (M10X1 5X35 10 9)POR	14058185
3.		8.900	BOLT, HFH (M10X1 5X40)(36 THD)10 9 PS	11509844
4.		8.900	BOLT, HFH (M8X1 25X75)9 8 POR	11508301
5.	D9	0.029	BOLT, ENG MT BRKT	10034857
6.	D9	0.002	WASHER, ENG MT BRKT (TO CYL BLK)	473539
7.		8.900	BOLT, HEX & CON TOOTH WA (M8-1 25X32)9 8 PH	11501843
8.	F17	2.275	GENERATOR, REMANUFACTURED	10463089
9.	F23	2.277	SHIELD, GEN HEAT	10085518
10.		8.917	NUT, HFH (M8X1 25X7 5)10 PEOR	11507036

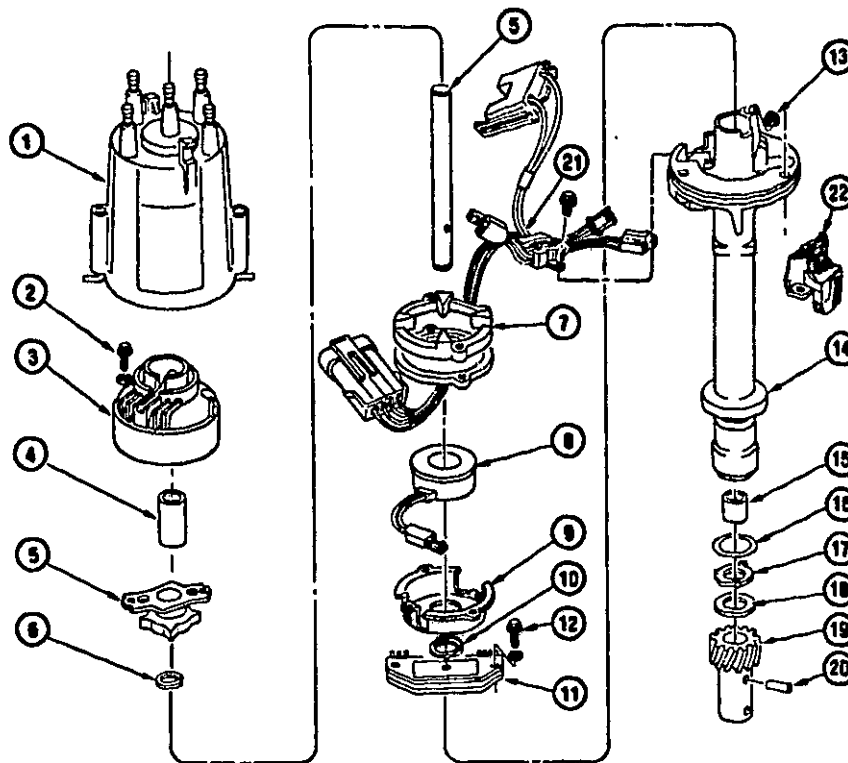

1984-1986 P DISTRIBUTOR/IGNITION-L4

NOTE: PART NUMBERS ARE CHARTED FOR YEARS 1985 AND LATER IN GROUP 2.000 SEE SPECIFIC GROUP FOR YEARS 1984 AND PRIOR.

1.	G2	2.367	CAP, DISTR
2.	G2	2.383	SCREW, W/WA. ROTOR
3.	G2	2.382	ROTOR, DISTR
4.		N.S.	BUSHING,(PART OF ITEM #14)
5.	G2	2.372	MAIN SHAFT, COMPLETE
6.	G2	2.372	RETAINER, POLE PIECE & PLATE
7.	G2	2.372	POLE PIECE AND PLATE,
8.		N.S.	COIL, PICK-UP (PART OF ITEM #7)
9.		N.S.	PLATE, ADVANCE (PART OF ITEM #7)
10.	G2	2.363	SEAL, HOUSING
11.	G2	2.383	MODULE, DISTR
12.	G2	2.383	SCREW, W/LW MODULE
13.	G2	2.372	PLUG, POLE PIECE & PLATE
14.	G2	2.362	HOUSING, DISTR
15.		N.S.	BUSHING,(PART OF ITEM #14)
16.	G2	2.383	SEAL, ON SHAFT
17.	G2	2.379	WASHER, TANG UNDER GEAR
18.	G2	2.379	WASHER, UNDER GEAR
19.	G2	2.374	GEAR, DISTR
20.		8.939	PIN, (3/16X11/16)(HEAVY SERIES TYPE C)
21.	G2	2.383	BLOCK, TERMINAL
22.	G2	2.383	SWITCH, HALL EFFECT

GM02-056
093086

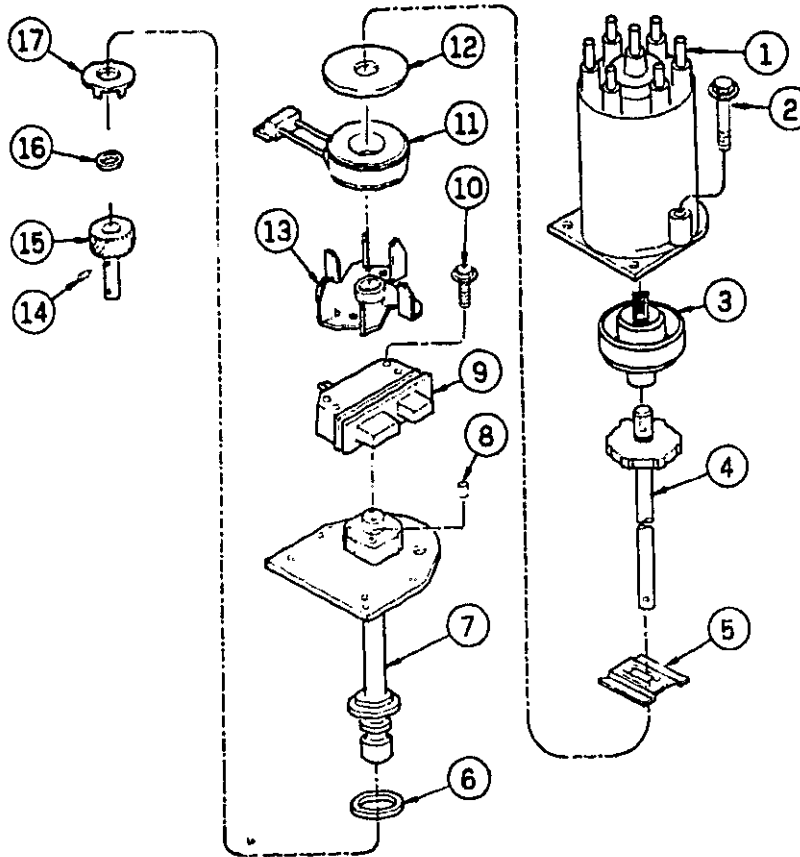

GM02-0583

1985-1988 P DISTRIBUTOR/IGNITION-2.8L V6 (L44/2.8-9)

1.	G2	2.367	CAP. DISTR	1989797
2.	G2	2.368	SCREW, W/LW. CAP ATTACH	10495298
3.	G2	2.382	ROTOR, DISTR	10497452
4.	G2	2.372	MAIN SHAFT, (1985)	1988005
	G2	2.372	MAIN SHAFT, (1986-88)	10497450
5.	G2	2.372	SHIELD, PICKUP COIL	1989792
6.	G2	2.363	SEAL, ON HSG	1977935
7.	G2	2.362	HOUSING, DISTR	10496785
8.		8.939	PIN, SLOTTED SPR (1/8X1/2)PL	455532
9.	G2	2.383	MODULE, DISTR (1985 OEM #1103633)	1987466
	G2	2.383	MODULE, DISTR (1985 OEM #1103694)(1986-88)	10496269
10.	G2	2.383	SCREW, W/LW. MODULE ATTACH	1987972
11.	G2	2.372	COIL, PICKUP	10495089
12.	G2	2.372	RETAINER, PICKUP COIL	1989282
13.	G2	2.372	POLE PIECE (STATIONARY)	1988010
14.		8.939	PIN, SPR COILED (3/16X3/4) PL	9422127
15.	G2	2.374	GEAR, DISTR	1986769
16.	G2	2.379	WASHER, UNDER GEAR	1977937
17.	G2	2.379	WASHER, TANG UNDER GEAR (1985 OEM #1103633)	1965864
	G2	2.379	WASHER, TANG UNDER GEAR (1985 OEM #1103694)(1986-88)	1965864

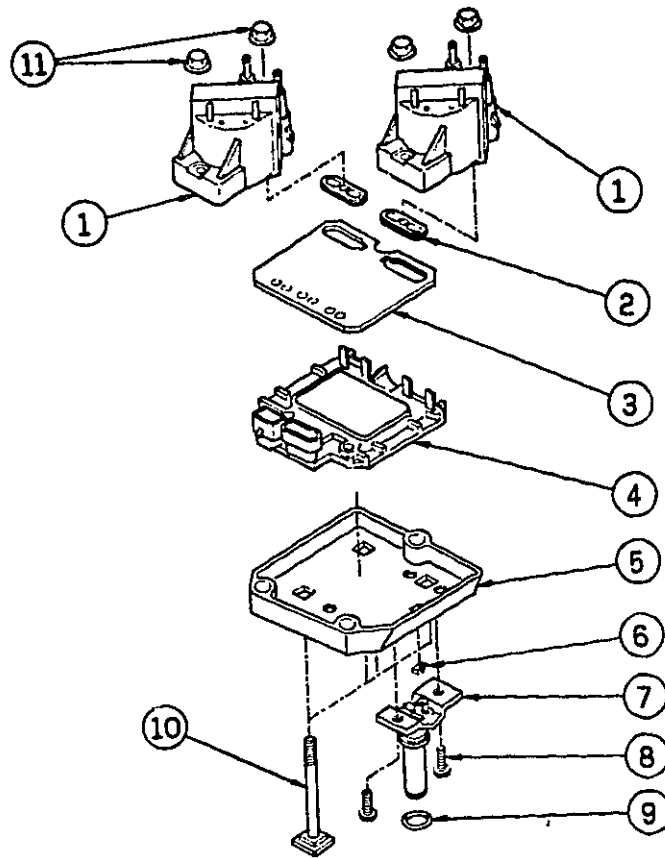

GM02-058

1987-1988 P COIL & MODULE/IGNITION (LR8/2.5R)(DELCO)

1.	F14	2.170	COIL, IGN	10497771
2.	F14	2.170	SEAL, ELEC IGN MOD & COIL(FOR 2 TERMS)	1989579
3.	F14	2.170	SHIELD, MTG	1989812
4.	G2	2.383	MODULE, IGN	10467208
5.	F14	2.183	BRACKET, MTG (1987-88)	10498100
	F14	2.183	BRACKET, MTG (1989-91)	10467995
6.	F14	2.170	SEAL, SENSOR & MODULE	1989823
7.	G2	2.383	SENSOR, IGN (CR/SHAFT POSTION)	10496122
8.	F14	2.170	SCREW, SENSOR ATTACH	10498732
9.	F14	2.170	SEAL, IGN (O-RING)(ON-SENSOR)	1989866
10.	F14	2.170	STUD, MOUNTING BRACKET ATTACH (2 183)	10498207
11.	G2	2.383	NUT, W/COIL ELEK IGN	1989530

2P02-005
020284

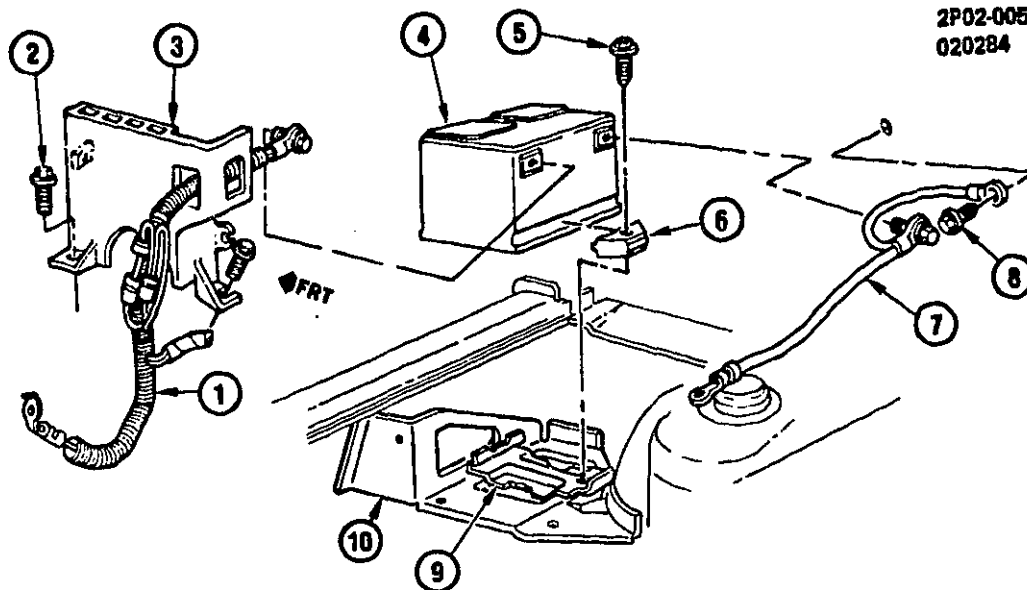

2P02-005

1984-1987 P BATTERY MOUNTING & CABLES

1.	F25	2.342	CABLE, BAT POS (32")X(1984)	12042424
	F25	2.342	CABLE, BAT POS (30")X(1985-87 W/LR8)	12011371
	F25	2.342	CABLE, BAT POS (35")X(1985-87 W/L44)	12026581
2.		8.977	SCREW, HWH TAP (M4 2X1 41X16)	11509374
3.	F25	2.343	SHIELD, BAT HEAT	10045872
4.		N.S.	BATTERY,	
5.		8.900	BOLT, HWH (M8X1.25X65)	11505840
6.	F23	2.335	RETAINER, BAT HOLDN	14005081
7.	F23	2.341	CABLE, BAT NEG (15")X(LR8)	8907024
	F23	2.341	CABLE, BAT NEG (25")X(1985-87 W/L44)X(2 342)	12003648
8.		8.977	BOLT, HWH TAP (M6 3X1 81X20)	12337828
9.	F23	2.333	SUPPORT, BAT HOLD DOWN	20489129
10.	F23	2.333	TRAY, BAT	10071787

2P02-012
052887

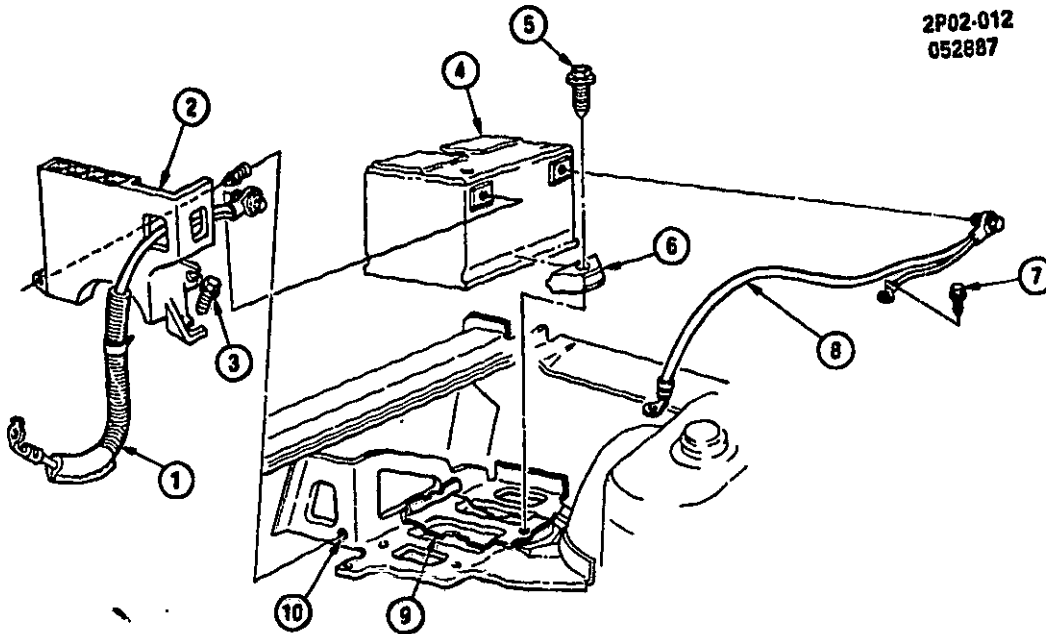

2P02-012

1988 P BATTERY MOUNTING & CABLES

1.	F25	2.342	CABLE, BAT POS (30"XW/LR8)	12011371
	F25	2.342	CABLE, BAT POS (35"X1988)	12028581
	F25	2.343	SLEEVE INSULATOR, BAT CBL POS (W/LR8)	10042766
2.	F25	2.343	SHIELD, BAT HT (1988)	10045872
3.		8.977	SCREW, HEX W/FL WA TAP (M4.2X1.41X16)600M NIC ORG	11509374
4.		N.S.	BATTERY	
5.		8.900	BOLT, HEX W/CON SPG LK WA (M8X1.25X65)POR	11605846
6.	F23	2.335	RETAINER, BAT HOLDN	14005081
7.		8.977	BOLT, SEMS HEX W/FL WA (M6.3X1.81X20)6010M PZOR	12397528
8.	F23	2.341	CABLE, BAT NEG (15"XLR8)	8907024
	F23	2.341	CABLE, BAT NEG (25"X1988 L44X2.342)	12003848
9.	F23	2.333	SUPPORT, BAT HOLD DOWN	20489129
10.	F23	2.333	TRAY, BAT TRAY (1988)	10071787

2P02-001
032489

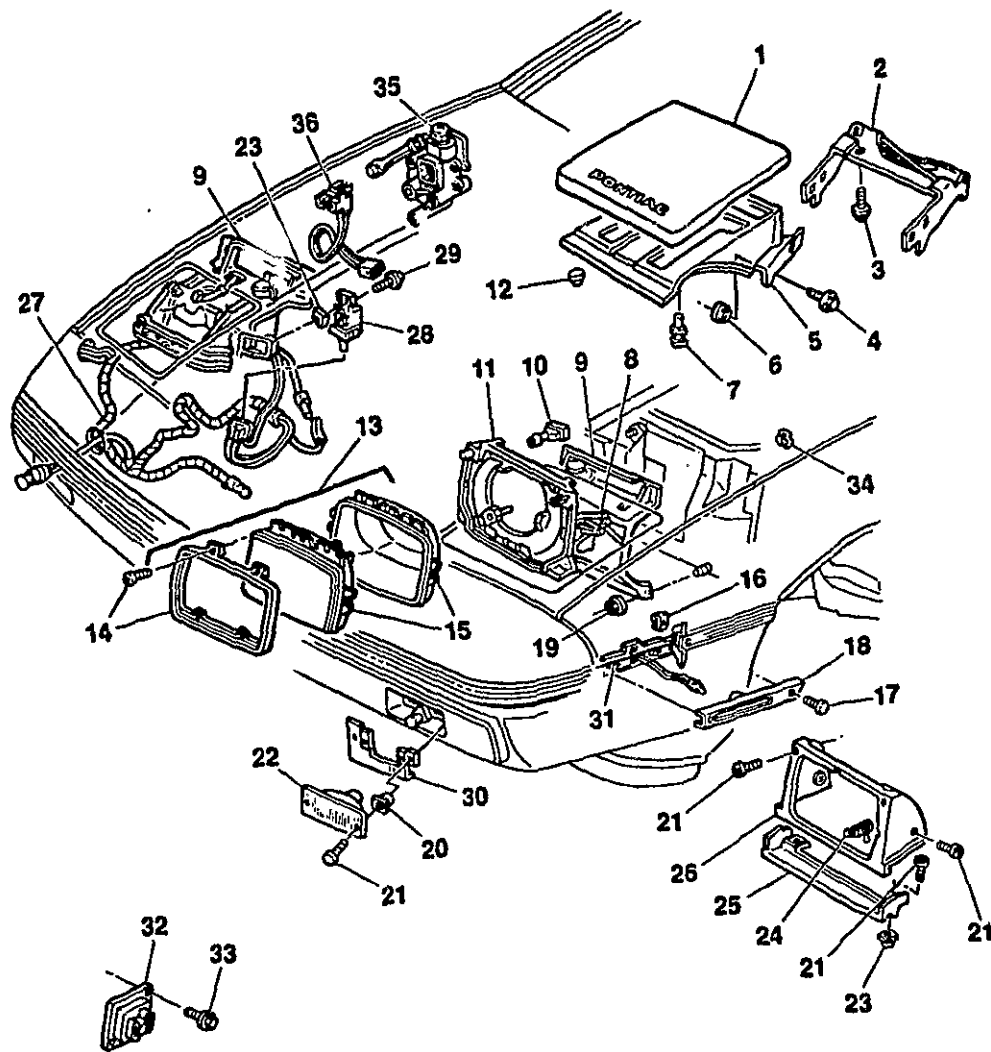

2P02-001

1984-1988 P LAMPS/FRONT

1.	G9	2.770	PANEL, HDLP CVR-RH	20302392
	G9	2.770	PANEL, HDLP CVR-LH	20302393
2.	G9	2.765	HINGE, CVR HDLP-RH	20318490
	G9	2.765	HINGE, CVR HDLP-LH	20318491
3.		8.977	SCREW, HWH-TYPE C (M6 X 1 X 20)	11508023
4.	G9	2.765	SCREW, HDLP CVR HGE	20459069
		8.977	SCREW, HEX W/TT CON WA TYPE C (M6X1X20)(1987)	11508023
5.	G8	2.726	FILLER, HDLP CVR PNL-RH (INC'LS #6)	20423522
	G8	2.726	FILLER, HDLP CVR PNL-LH (INC'LS #6)	20423523
6.		N.S.	SPACER, (PART OF #5)	
7.	N24	8.133	RIVET, PUSH-IN	20433026
8.	G9	2.765	CRANK KIT, HDLP MTR ARM-W/LINK-RH (1984-88)(* 1)	16510928
	G9	2.765	CRANK KIT, HDLP MTR ARM-W/LINK-LH (1984-88)(* 1)	16510927
9.	G8	2.760	BRACKET KIT, MTR MTG-LH(* 2)	16502817
	G8	2.760	BRACKET KIT, MTR MRG-RH(* 2)	16502818
10.	G8	2.737	SCREW, HDLP ADJ-W/NUT	557057
	G8	2.729	NUT, SPL ANC (NYLON)(SQUARE HOLE)	347347
11.	G8	2.726	BODY KIT, HDLP-RH	16502820
	G8	2.726	BODY KIT, HDLP-LH	16502819
	G8	2.760	BOLT, HDLP DR MTR-W/SCREW	10021637
	G9	2.765	WASHER, PIVOT BOLT	10018028
	G9	2.765	BOLT, HDLP BODY PIVOT	10020785
12.	G8	2.765	BUMPER, FILLER (12 050)	20201325
13.	G8	2.725	CAPSULE, HDLP	5972860
14.	G8	2.731	RING, HDLP RET	5989466
	G8	2.736	SCREW, HDLP RET RING	5986249
15.	G8	2.727	SEALBEAM, HDLP	5972698
	G8	2.726	RING, HDLP MTG	5988095
16.		8.921	NUT, U-SHAPE (#8-18)	1635216
17.		8.977	SCREW, PAN HD TORX TAP (M4 2X1 41X30)	11505835
18.	G6	2.576	LAMP, FRT SI MKR-RH (1984-85)(1986 PM)	920058
	G6	2.576	LAMP, FRT SI MKR-LH (1984-85)(1986 PM)	920057
	G6	2.576	LAMP, FRT SI MKR-RH (1986 PG)	5974302
	G6	2.576	LAMP, FRT SI MKR-LH (1986 PG)	5974301
	G6	2.576	LAMP, FRT SI MKR-RH (1987-89 PM)	5974302
	G6	2.576	LAMP, FRT SI MKR-LH (1987-89 PM)	5974301
	G6	2.575	SOCKET, SI MKR LP (1984-86)(1987-89 PG)	12083480
19.		8.917	NUT, W/CON WA (M6X1X5.5)	11508388
20.	G8	2.729	NUT, SPL ANC (NYLON)(SQUARE HOLE)	347347
21.		8.977	SCREW, PAN HD TORX TAP (M4 2X1 41X20)	11504655
22.	G6	2.585	LAMP, PK & T/SIG-RH	917328
	G6	2.585	LAMP, PK & T/SIG-LH	917327
	G10	2.892	FLASHER, T/SIG LP	10041073
23.	G8	2.729	NUT, SPL ANC (NYLON)(SQUARE HOLE)	347347
24.	G8	2.737	SPRING, HDLP ADJ	549398
25.	G8	2.728	BEZEL, HDLP LWR-RH	10019917
	G8	2.728	BEZEL, HDLP LWR-LH	10019918
26.	G8	2.728	BEZEL, HDLP UPR-RH	10019919
	G8	2.728	BEZEL, HDLP UPR-LH	10019920
27.	G3	2.480	HARNESS, FWD LP (1984 EXC C60)	12027624
	G3	2.480	HARNESS, FWD LP (1984 W/C60)	12039080
	G3	2.480	HARNESS, FWD LP (1985-86 C60,V08)	12039080
	G3	2.480	HARNESS, FWD LP (1985-86 EXC C60,V08)	12039079
	G3	2.480	HARNESS, FWD LP (1985-86 C60,V08)	12039079
	G3	2.480	HARNESS, FWD LP (1987 EXC V08)	12046567
	G3	N.S.	HARNESS, FWD LP (1987 W/V08)	
	G3	2.480	HARNESS, FWD LP (1988-89)	12080965
28.	G8	2.755	RELAY, HDLP ACTR	10031018
	G8	2.755	RELAY, HDLP ACTR (AT RAD BFL)	10022620
	G8	2.755	BRACKET, HDLP ACTR RELAY (3 900)	10022615
29.		8.977	SCREW, HWH (M4.2X1 41X16)	22508732
30.	G6	2.587	BRACKET, P/LP-RH	10036891
	G6	2.587	BRACKET, P/LP-LH	10036892
31.	N24	8.141	REINFORCEMENT, F/FDR AT SI MKR	20568810
32.	G8	2.755	MODULE, HDLP OPG DR ACTR CONT	16505400
33.		8.977	SCREW, HEX W/FL WA TAP (M4 2X1 41X16)NIC ORG	11509374
34.	G8	2.760	CLIP, HDLP MTR CRANK (PART OF ITEM 8)	10020724
35.	G8	2.760	ACTUATOR, HDLP-RH (1984-86)	22039673
	G8	2.760	ACTUATOR, HDLP-LH (1984-86)	22039672
	G8	2.760	MOTOR, W/ACTUATOR,HDLP DR-RH (1987-88)	16507926
	G8	2.760	MOTOR, W/ACTUATOR,HDLP DR-LH (1987-88)	16507925
36.	G8	2.755	SWITCH, W/BRUSH,HDLP (1984-86)	22038870

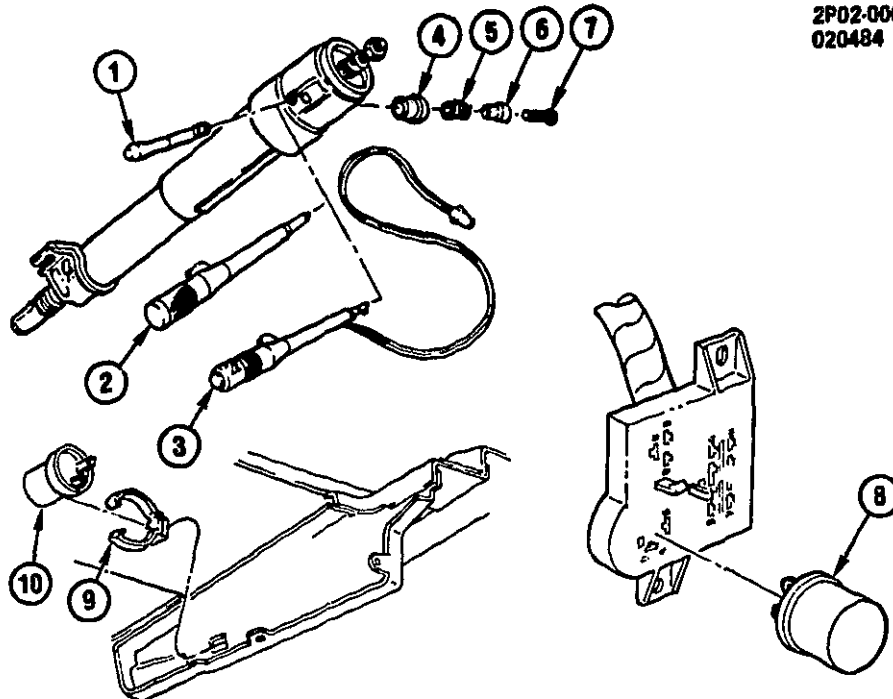

2P02-006

1984-1988 P TURN SIGNAL LEVER & RELAYS

1.	N21	6.514	LEVER, TILT COL REL	10024521
2.	G10	2.897	LEVER, T/SIG-WSW-WSWA-D/SW (EXC PULSE.K34)(1984-87)	22510143
	G10	2.897	LEVER, T/SIG-WSW-WSWA-D/SW (1984-86 PULSE)	22510144
	G10	2.897	LEVER, T/SIG-WSW-WSWA-D/SW (EXC PULSE.K34)(1988-89)	22510733
	G10	2.897	LEVER, T/SIG-WSW-WSWA-D/SW (1987-89 PULSE)	22510732
3.	G10	2.897	LEVER, T/SIG-WSW-WSWA-D/SW (K34 EXC PULSE)	25111263
	G10	2.897	LEVER, T/SIG-WSW-WSWA-D/SW (PULSE.K34)	25111262
4.	G6	2.575	KNOB, HAZARD WRNG SW	22507977
5.	G6	2.575	SPRING, HAZARD WRNG SW KNOB	556743
6.	G6	2.575	BUTTON, HAZARD WRNG SW	556742
7.		8.977	SCREW, OV HD C/R TAP (M3.5 X 1.27 X 22)	
8.	G6	2.575	FLASHER, HAZARD WRNG	8450089
9.	G10	2.892	CLIP, T/SIG LP FLSHR	25534019
10.	G10	2.892	FLASHER, T/SIG LP	10041073

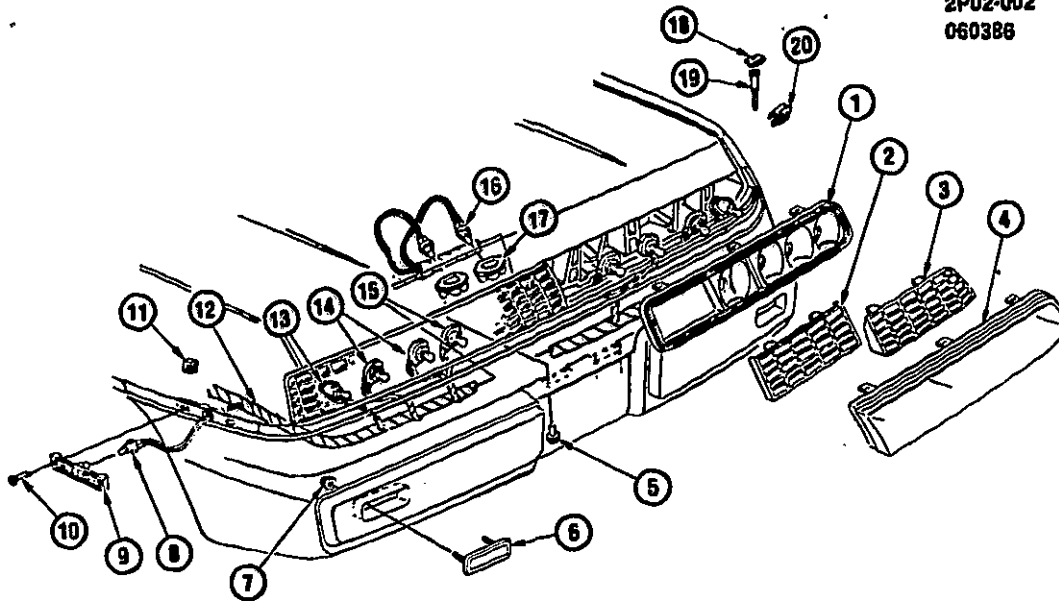

2P02-002

1984-1985 P LAMPS/REAR

1.	G7	2.680	HOUSING, RR COMP LP-RH	16500454
	G7	2.680	HOUSING, RR COMP LP-LH	16500453
2.	G7	2.682	LENS, B/U LP INR	16500460
3.	G7	2.682	LENS, RR COMP LP INR-RH	16500458
	G7	2.682	LENS, RR COMP LP INR-LH	16500457
4.	G7	2.682	LENS, RR COMP LP OTR-RH	16500462
	G7	2.682	LENS, RR COMP LP OTR-LH	16500461
5.		8.977	SCREW, LG RD HD (M4.2X1.41X20)	
6.	G7	2.689	REFLECTOR, RR BPR	919838
7.		8.921	NUT, FLG STMPD (SEALER)(M6.3X24)	
8.	G6	2.575	SOCKET, SI MKR LP	12083460
		8.991	BULB, RR SI MKR (#194)	
9.	G6	2.575	LAMP, RR SI MKR-RH	920080
	G6	2.575	LAMP, RR SI MKR-LH	920059
10.		8.913	SCREW, PAN HD TORX TAP (M4.2X1.41X30)	
11.		8.921	NUT, U-SHAPE (#8-18)	
12.	N27	13.090	HARNES, RR COMPT(*1)	20480232
13.	G6	2.598	SOCKET, TAIL LP-W/CBL	12030055
		8.991	BULB, TAIL-STOP-DIR (#2057)	
14.	G7	2.594	SOCKET, T/SIG-TAIL-STOP LP-W/CBL	12003757
		8.991	BULB, TAIL-STOP-DIR (#2057)	
15.	G6	2.598	SOCKET, B/U LP-W/CBL	12003758
		8.991	BULB, B/U LP (1D1156-32CP)	
16.	G8	2.714	SOCKET, LIC PLT LP	12001470
		8.991	BULB, 194	
17.	G8	2.700	LAMP, LIC PLT	912116
18.	G7	2.664	PLUG, TAIL LP ACCESS HOLE (BLACK)	20387360
19.	G7	2.689	SCREW, RR LP TO PNL (P37)	20455727
20.	G7	2.664	CLIP, TAIL LP RET	20380246

NOTE 1: SEE GROUP FOR ADDITIONAL USAGE.

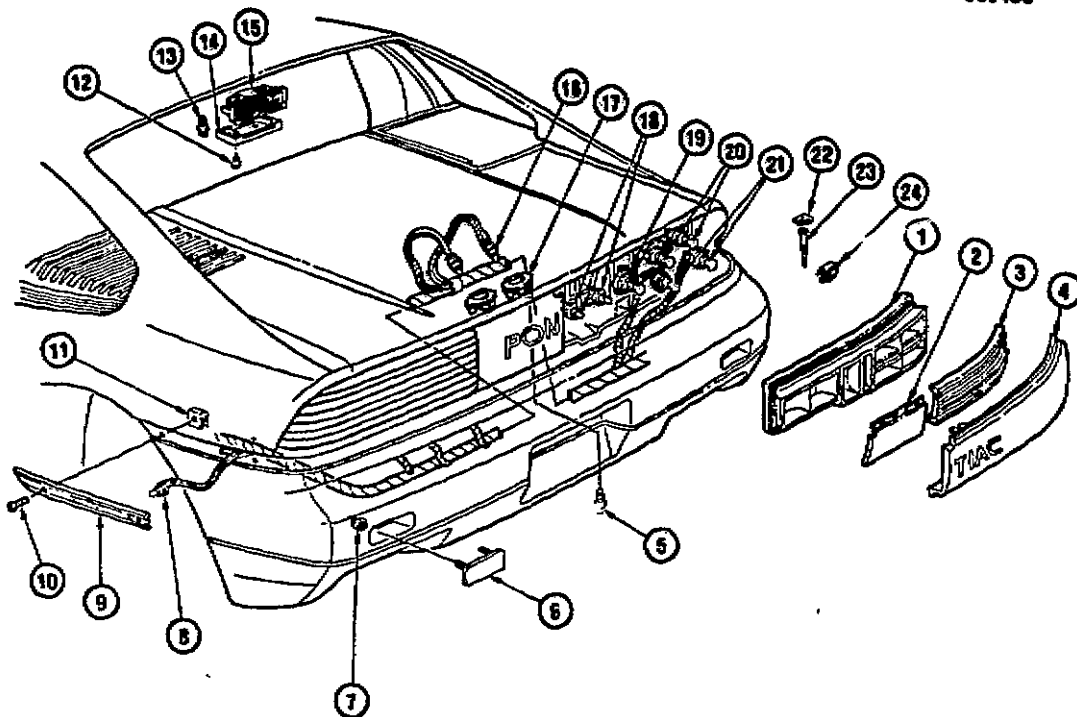

2P02-007

1986-1988 PG97 LAMPS/REAR

1.	G7	2.680	HOUSING, RR COMB LP-RH	16504924
	G7	2.650	HOUSING, RR COMB LP-LH	16504923
2.	G7	2.689	LENS, RR COMB INR LENS INR-RH	16504936
	G7	2.689	LENS, RR COMB INR LENS INR-LH	16504935
3.	G7	2.689	LENS, RR COMB INR-RH	16504928
	G7	2.689	LENS, RR COMB INR-LH	16504927
4.	G7	2.682	LENS, RR COMB OVERLAY MLD-RH	16504930
	G7	2.682	LENS, RR COMB OVERLAY MLD-LH	16504929
5.	G7	8.977	SCREW, LG RD HD TORX (M4.2X1.41X20)	
6.	G7	2.689	REFLECTOR, RR BPR (1986-87)	919638
	G7	2.689	REFLECTOR, RR BPR (1988)	5974633
7.	N22	7.831	NUT, RR BPR REFL TO FASCIA	10042621
8.	G8	2.576	SOCKET, SI MKR LP	12093460
	G8	8.991	BULB, SI MKR LP (2CP-#194)	9421330
9.	G8	2.576	LAMP, RR SI MKR-RH	5975140
	G8	2.576	LAMP, RR SI MKR-LH (1986-88)	5975139
10.		8.977	SCREW, PAN HD TORX (M4.2X1.41X30)	11505835
11.		8.921	NUT, U SHAPE (M4.2 X 1.41 X .065)ZOR	52351724
12.		8.977	SCREW, PN HD (M4.2X1.41X16)	11501012
13.		8.977	SCREW, HWH (1/4"X1 3/8")	
14.	G7	2.679	COVER, HIGH MTD STOP LP	16505094
15.	G7	2.679	LAMP, HIGH MTD STOP (1986)	918421
16.	G8	2.714	SOCKET, LIC PLT LP-W/CBL	12001470
	G8	8.991	BULB, LIC LP (2CP-#194)	9421330
17.	G8	2.700	LAMP, LIC PLT	912116
18.	G8	2.714	SOCKET, B/U LP W/CBL	12001470
	G8	8.991	BULB, (2CP-#194)	9421330
19.	G8	2.596	SOCKET, B/U LP-W/CBL	12003768
	G8	8.991	BULB, B/U LP (32CP-#1156)	9417866
20.	G7	2.694	SOCKET, T/SIG LP-W/CBL	12003757
	G7	8.991	BULB, TAIL-STOP-DIR SIG (#2057)	9438648
21.	G7	2.694	SOCKET, TAIL-STOP LP-W/CBL	12003757
	G7	8.991	BULB, (#2057)	9438648
22.	G7	2.664	PLUG, TAIL LP ACCESS HOLE (BLACK)	20367360
23.	G7	2.660	SCREW, RR LP TO PNL	20596339
24.	G7	2.664	CLIP, TAIL LP RET	20360246

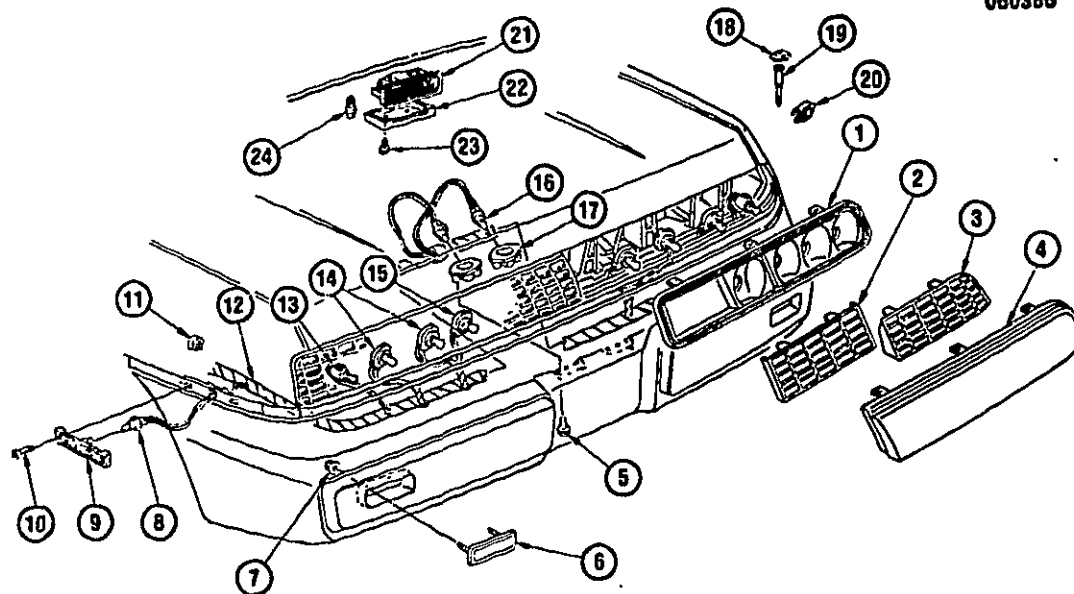

2P02-009

1986-1988 PM37 LAMPS/REAR

1.	G7	2.680	HOUSING, RR COMP LP-RH	16500454
	G7	2.680	HOUSING, RR COMP LP-LH	16500453
2.	G7	2.682	LENS, B/U LP INR	16500460
3.	G7	2.682	LENS, RR COMP LP INR-RH	16500458
	G7	2.682	LENS, RR COMP LP INR-LH	16500457
4.	G7	2.682	LENS, RR COMP LP OTR-RH	16500462
	G7	2.682	LENS, RR COMP LP OTR-LH	16500461
5.		8.977	SCREW, LG RD HD (M4.2X1.41X20)	
6.	G7	2.689	REFLECTOR, RR BPR (1986)	919638
7.		8.921	NUT, FLG STMPD (SEALER)(M6.3X24)	
8.	G6	2.575	SOCKET, SI MKR LP	12083460
		8.991	BULB, RR SI MKR (#194)	
9.	G6	2.575	LAMP, RR SI MKR-RH (1986-87 PM)	920060
	G6	2.575	LAMP, RR SI MKR-LH (1986-87 PM)	920059
	G6	2.575	LAMP, RR SI MKR-RH (1987 EXC SPCL EDITION W69)(1988)	5975140
	G6	2.575	LAMP, RR SI MKR-LH (1987 EXC SPCL EDITION W69)(1988)	5975139
10.		8.913	SCREW, PAN HD TORX TAP (M4.2X1.41X30)	
11.		8.921	NUT, U-SHAPE (#8-18)	
12.	N27	13.080	HARNES, RR COMPT(*1)	20624388
13.	G6	2.596	SOCKET, TAIL LP-W/CBL	12030055
		8.991	BULB, TAIL-STOP-DIR (#2057)	9438848
14.	G7	2.684	SOCKET, T/SIG-TAIL-STOP LP-W/CBL	12003757
		8.991	BULB, TAIL-STOP-DIR (#2057)	9438848
15.	G6	2.596	SOCKET, B/U LP-W/CBL	12003758
		8.991	BULB, B/U LP (1D1156-32CP)	9417866
16.	G8	2.714	SOCKET, LIC PLT LP	12001470
		8.991	BULB, (#194)	9421330
17.	G8	2.700	LAMP, LIC PLT	912116
18.	G7	2.684	PLUG, TAIL LP ACCESS HOLE (BLACK)	20367360
19.	G7	2.689	SCREW, RR LP TO PNL (P37)	20455727
20.	G7	2.684	CLIP, TAIL LP RET	20360246
21.	G7	2.679	LAMP, HIGH MTD STOP	918421
		8.991	BULB, W/SOCKET (43CP-#889)	9441722
		8.921	NUT, U SHAPE (M4.2X1.41)ZOR	52351724
22.	G7	2.679	COVER, HIGH MTD STOP LP	16505094
23.		N.S.	SCREW	
24.		N.S.	STUD, LP MTG	

NOTE 1: SEE GROUP FOR ADDITIONAL USAGE.

PONTIAC CHASSIS GROUP 3.000

ILLUSTRATION INDEX

TITLE	GRID
1984	P FUEL SUPPLY SYSTEM F4
1985-1986	P FUEL SUPPLY SYSTEM-2.5L L4 (LR8/2.5R) F5
1985-1986	P FUEL SUPPLY SYSTEM-2.8L V6 (L44/2.8R) F8
1987-1988	P FUEL SUPPLY SYSTEM F10
1985-1988	P FUEL INJECTOR RAIL MPFI (MODELS F6A,R610) (L44/2.8-9) F11
1984-1986	P THROTTLE BODY/TBI (MODEL 300) F13
1985-1988	P THROTTLE BODY/MPFI L44/2.8-9 F14
1987-1988	P THROTTLE BODY/TBI (MODEL 700)(LR8/2.5R) F15
1987-1988	P AIR INTAKE SYSTEM-L4 (LR8/2.5R) F17
1985	P AIR INTAKE SYSTEM-V6 (L44/2.8-9) F18
1986-1988	P AIR INTAKE SYSTEM-V6 (L44/2.8-9) F19
1984-1985	P ACCELERATOR CONTROL-L4 (LR8/2.5R) F20
1986	P ACCELERATOR CONTROL-L4 (LR8/2.5R) F21
1987-1988	P ACCELERATOR CONTROL-L4 (LR8/2.5R) F22
1985-1988	P ACCELERATOR CONTROL-V6 (L44/2.8-9) F23
1984	P CRUISE CONTROL-L4 (LR8/2.5R)(K34) F25
1985	P CRUISE CONTROL-L4 (LR8/2.5R)(K34) F27
1986	P CRUISE CONTROL-L4 (LR8/2.5R)(K34) G3
1987-1988	P CRUISE CONTROL-L4 (LR8/2.5R)(K34) G5
1985-1988	P CRUISE CONTROL-V6 (L44/2.8-9)(K34) G7
1984	P EMISSION CONTROLS-L4 (LR8/2.5R) G9
1985-1986	P EMISSION CONTROLS-L4 (LR8/2.5R) G12
1987-1988	P EMISSION CONTROLS-L4 (LR8/2.5R) G15
1985-1988	P EMISSION CONTROLS-V6 (L44/2.8-9) G18
1984	P EXHAUST SYSTEM-L4 (LR8/2.5R EXC Y82) G20
1984	P EXHAUST SYSTEM-L4 (LR8/2.5R W/Y82) G21
1985-1987	P EXHAUST SYSTEM-L4 (LR8/2.5R) G22
1988	P EXHAUST SYSTEM-L4 (LR8/2.5R) G23
1985-1988	P EXHAUST SYSTEM-V6 (L44/2.8-9) G24

2P03-002
102887

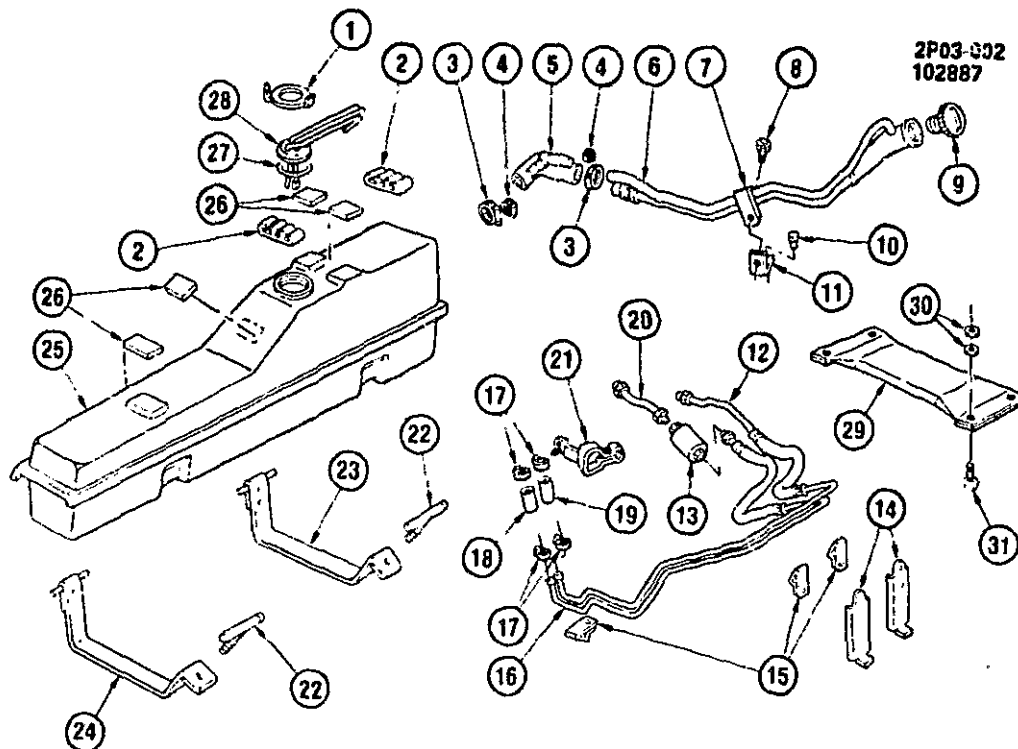

2P03-002

1984 P FUEL SUPPLY SYSTEM

1.	A7	3.107	CAM, FUEL SENDER	22518548
2.	A7	3.107	INSULATOR, FUEL SENDER PIPE	10026387
3.	N18	1.166	CLAMP, HOSE (33 3 TO 57 2MM)	22518666
4.	N18	1.166	CLAMP, WORM TYPE (56"TC 1 06"DIA)	22518665
5.	A7	3.003	HOSE, FUEL TANK FIL	10026636
6.		N.S.	PIPE, FUEL TANK FIL	
7.		N.S.	CLAMP, FUEL TNK FIL PIPE	
8.		8.977	SCREW, HWH (1/4" - 14 X 3/4")	
9.	A7	3.026	CAP, W/HANDLE, FUEL TANK (GAS)	22525302
10.		N.S.	RIVET, FUEL TNK FIL PIPE BRKT	
11.	A7	3.003	BRACKET, F/TNK FIL PIPE	10026509
12.	A10	3.163	PIPE, FUEL RETURN	10035094
13.	B9	3.890	FILTER, FUEL (TYPE GF481)	25055052
14.	A9	3.162	BRACKET, FUEL FEED FRT PIPE CLIP	10026211
15.		8.950	CLIP, CLSD (1/4"-5/16" PIPE X 17/32" X 1/2")	
16.	A10	3.163	PIPE, FUEL FEED	10026222
17.	N18	1.166	CLAMP, WORM TYPE (56"TO 1 06"DIA)	22518665
18.		8.962	HOSE, FUEL & OIL (3/8" X 25"X1")	
19.		8.982	HOSE, BULK (5/16" X 25"X1")	
20.	A10	3.163	PIPE, FUEL FEED TBI TO FLTR	10026358
21.	B9	3.890	CLAMP, FUEL FILTER	10039217
22.	A7	3.023	BOLT, FUEL TANK STRAP	10040191
23.	A7	3.022	STRAP, FUEL TANK (RR)	10021735
24.	A7	3.022	STRAP, FUEL TANK (FRT)	10033889
25.	A7	3.001	TANK, FUEL	10037262
26.		N.S.	ANTI-SQUEAK, FUEL TANK	
27.	A9	3.112	GASKET, FUEL METER (TANK UNIT)	3893116
28.	A7	3.107	SENDER, FUEL (IN TANK)	25003251
	B9	3.900	PUMP, FUEL (IN TANK)	6471959
	A9	3.110	FILTER, FUEL (IN TANK)	25055455
29.	N28	12.981	REINFORCEMENT, FLR PAN AT F/TNK	20462096
30.		8.927	WASHER, SL (4 ID.25 OD)X4 THK)RUB	20733729
31.		8.900	BOLT, HEX FLGD (M8X1 25X16)9 8 PC	11507022

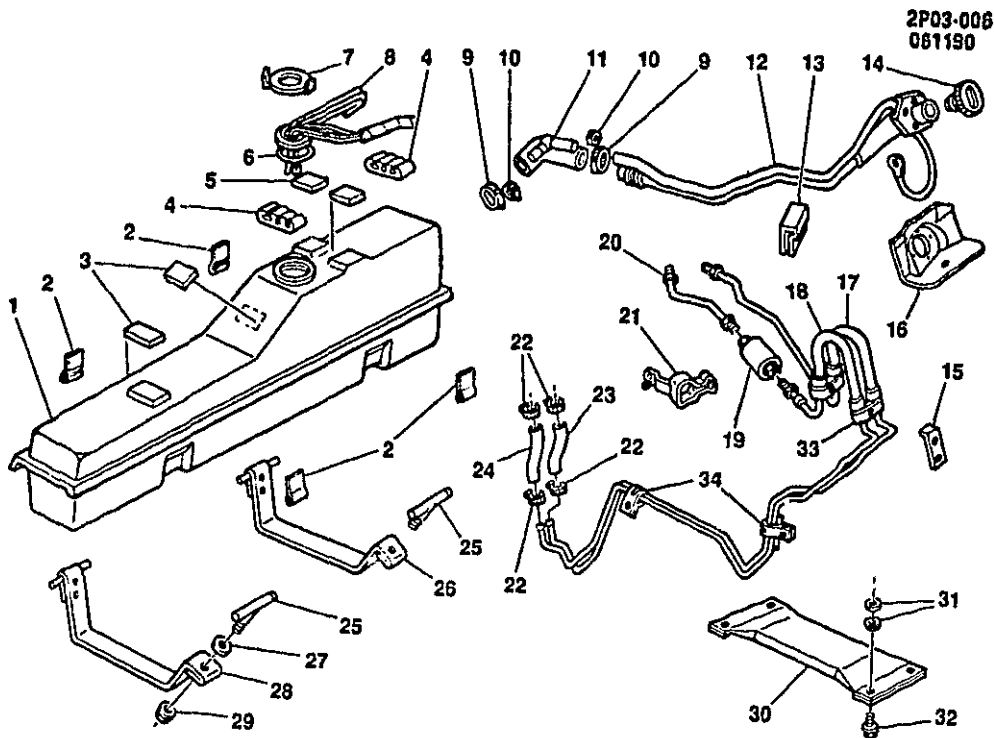

2P03-006
061150

2P03-006

1985-1986 P FUEL SUPPLY SYSTEM-2.5L L4 (LR8/2.5R)

1.	A7	3.001	TANK, FUEL	10037262
2.		N.S.	ANTI-SQUEAK, F/TK	
3.		N.S.	MAT, RR FLR AUX	
4.	A7	3.107	INSULATOR, FUEL SDR PIPE	10026387
5.		N.S.	ANTI-SQUEAK, F/TK RR	
6.	A9	3.112	GASKET, F/TK METER	3893116
7.	A7	3.107	CAM, FUEL SDR	22516548
8.	A7	3.107	SENDER, FUEL (1985)	25090578
	A7	3.107	SENDER, FUEL (1986)	25090910
	B9	3.900	PUMP, FUEL (IN TK)(1986)	6472421
	B9	3.900	PUMP, FUEL (IN TK)(EP125X1986)	6472526
	A9	3.110	FILTER, FUEL (IN TK)	25055455
9.	N18	1.168	CLAMP, WORM GR (28.6 TO 76.2MM)	12338017
10.	N18	1.166	CLAMP, WORM GR (56 TO 1.06)	22516665
11.	A7	3.003	HOSE, F/TK FIL & VENT	10026636
12.	A7	3.003	PIPE, F/TK FIL (W/GRD STRP)	10037635
13.	A7	3.008	INSULATOR, F/TK FIL PIPE	10034610
14.	A7	3.026	CAP, W/HDL F/TK (GAS)	22525302
15.	A9	3.162	BRACKET, F/FEED & RTN HOSE (POS 12)	10039215
16.	A7	3.003	PLATE, F/TK FIL PIPE	20534622
17.	A10	3.163	PIPE, F/FEED (SDR TO TBI)	10037188
	A10	3.163	HOSE, F/FEED RETURN (2 B-9)	10039222
18.	A10	3.163	PIPE, F/FEED (SDR TO FLTR)	10041102
19.	B9	3.890	FILTER, FUEL (TYPE GF481)	25055052
20.	A10	3.163	PIPE, F/FEED (TBI TO FLTR)	10037187
21.	B9	3.890	CLAMP, FUEL FLTR	10037190
22.		8.948	CLAMP, WORM GR HEX SL SCR (250X625) SST BLA	1648216
23.		8.962	HOSE, FUEL & OIL 3/8"X25' GM-6163MIAR(1)	
24.		8.962	HOSE, BULK 5/16X25' GM6163M FUEL & OIL RESISTANT(ARI(1)	
25.	A7	3.023	BOLT, F/TK STRP TO U/BODY (T BOLT)	10040191
26.	A7	3.022	STRAP, F/TK RR	10021735
27.	N24	7.831	NUT, RR BPR REFL	10039515
28.	A7	3.022	STRAP, F/TK FRT	10033889
29.		8.917	NUT, HEX M8-1.25 TORQUE PREV 10(ARI)	11500760

NOTE 1 CUT AS REQUIRED

30.	N28	12.981	REINFORCEMENT, FLR PAN AT F/TK (1985)
	N28	12.981	REINFORCEMENT, FLR PAN AT F/TK (1986)
31.		8.927	WASHER, SEALING, 4 ID. 25 OD. M4 THK. RUB (AR)
32.		8.900	BOLT, HFH MBX1 25X16 17 6-OD 9 8 PZOR (AR)

20482098
20819749
20733729
11507022

NOTE 1 CUT AS REQUIRED

2P03-027
040290

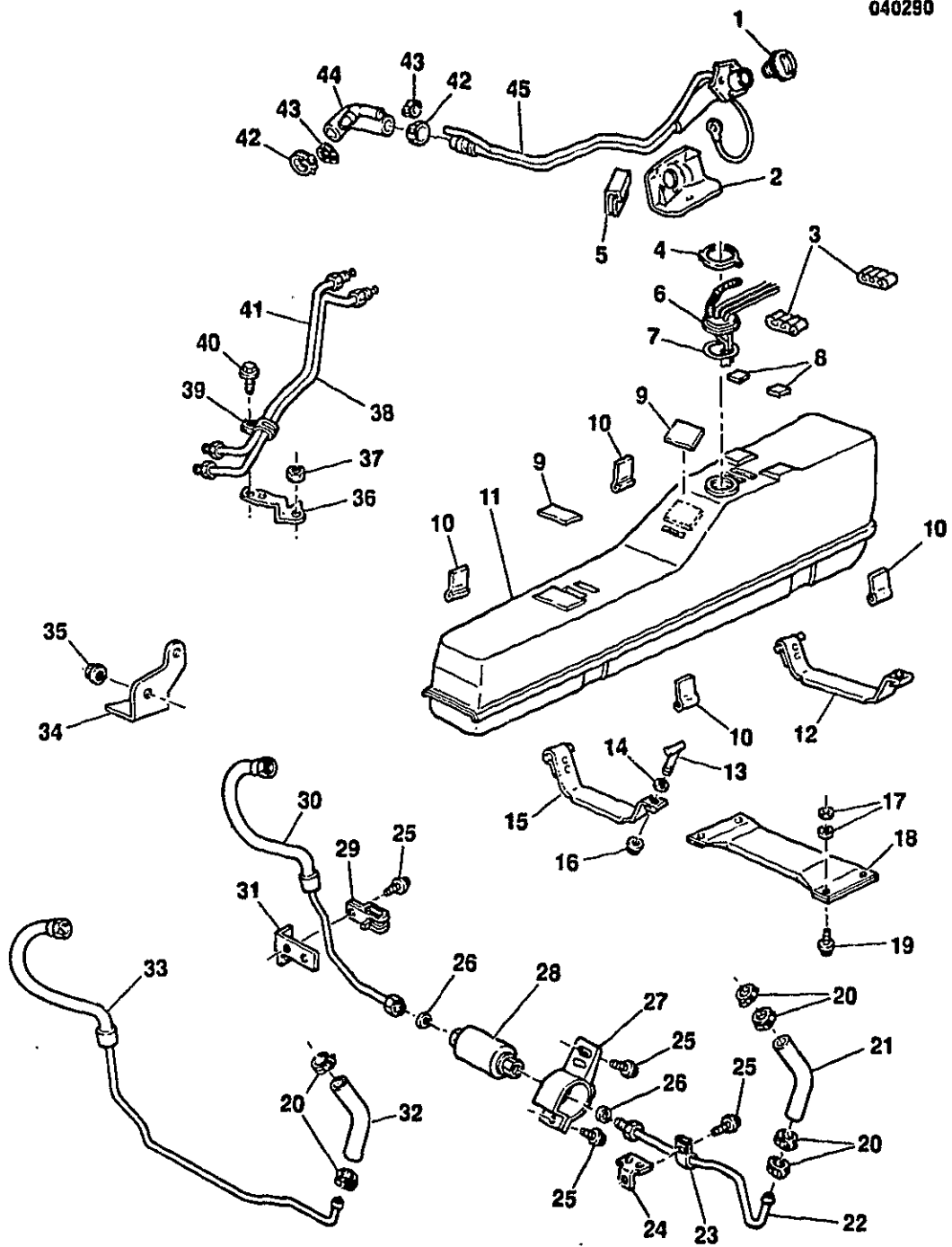

2P03-027

1985-1986 P FUEL SUPPLY SYSTEM-2.8L V6 (L44/2.8R)

1.	A7	3.028	CAP, W/HDL F/TK (GASOLINE)	10052116
2.	A7	3.003	PLATE, TK FIL, PIPE ATCH	20534622
3.	A7	3.107	INSULATOR, SENDER PIPE	10026387
4.	A7	3.107	CAM, SENDER	22516548
5.	A7	3.008	INSULATOR, TK FIL PIPE	10034810
6.	A7	3.107	SENDER (1985)	25004826
	A7	3.107	SENDER (1986)	25090912
7.	A9	3.112	GASKET, TK METER	3893116
8.		N.S.	ANTI-SQUEAK, TK RR	
9.		N.S.	MAT, RR FLR AUX	
10.		N.S.	ANTI-SQUEAK, TK	
11.	A7	3.001	TANK	10037262
12.	A7	3.022	STRAP, TK (RR)	10021735
13.	A7	3.023	BOLT, TK STRAP (T BOLT)	10040191
14.		8.921	NUT, PUSH ON (M8X1 25) ZOR	10009923
15.	A7	3.022	STRAP, TK (FRT)	10033889
16.	D28	4.898	NUT, HEX LK (M8X1 25) 10 CAD	11500760
17.		8.927	WASHER, FL 4 OMM RUB PL	20733729
18.	N28	12.981	REINFORCEMENT, FLR PAN AT F/TK	20819749
19.		8.900	BOLT, W/FL WA (M8X1 25X16) 9 8 ZOR	11507022
20.		8.948	CLAMP, WORM GR (250 TO 650) SST BLA	1648216
21.		8.982	HOSE (3/8)"(1)	9439238
22.	A10	3.163	PIPE, FEED	10039223
23.	C11	4.128	CLIP, FEED PIPE	22518924
24.	A9	3.162	BRACKET, FEED FRT PIPE (POS 8)	10034781
25.		8.977	SCREW, HEX HD W/FL WA (M6 3X1 81X20) PZOR	12337828
26.	A10	3.163	SEAL, O RING	22514722
27.	B9	3.890	CLAMP, TBI FUEL FLTR	10039217
28.	B9	3.890	FILTER (AC GF481)	25055052
29.	A9	3.162	CLIP, FEED & RTN PIPE	10042838
30.	A10	3.163	HOSE, FEED	10041404
31.	A9	3.162	BRACKET, FEED & RTN HOSE (POS 10) LWR	10036173
32.		8.982	HOSE (5/16)XGM6163M("1)	9439550
33.	A10	3.163	HOSE, RTN	10039222
34.	A10	3.163	SHIELD, PIPE	10036499
35.	A9	3.162	NUT, FEED & RTN PIPE BRKT (0 0334)	12337995
36.	A9	3.162	BRACKET, FEED & RTN HOSE	10034785
37.		8.915	NUT, HEX M8X1 25X13) PHOS	11500749
38.	A10	3.163	PIPE, RTN	10048644
39.	A9	3.162	CLIP, FEED & RTN PIPE	10042838
40.		8.977	SCREW, HWH (M6 3X1 81X13) PZOR	12338139
41.	A10	3.163	PIPE, FEED	10048643
42.	A24	3.675	CLAMP, WORM GR (28 6MM TO 76 2MM) SST BLA	12338017
43.	N18	1.168	CLAMP, WORM GR (9/16 TO 1 1/16)	22518685
44.	A7	3.003	HOSE, TK FIL & VENT	10028636
45.	A7	3.003	PIPE, TK FIL (W/GRD STRAP)	10037635

NOTE 1 CUT AS REQUIRED

2P03-021
050288

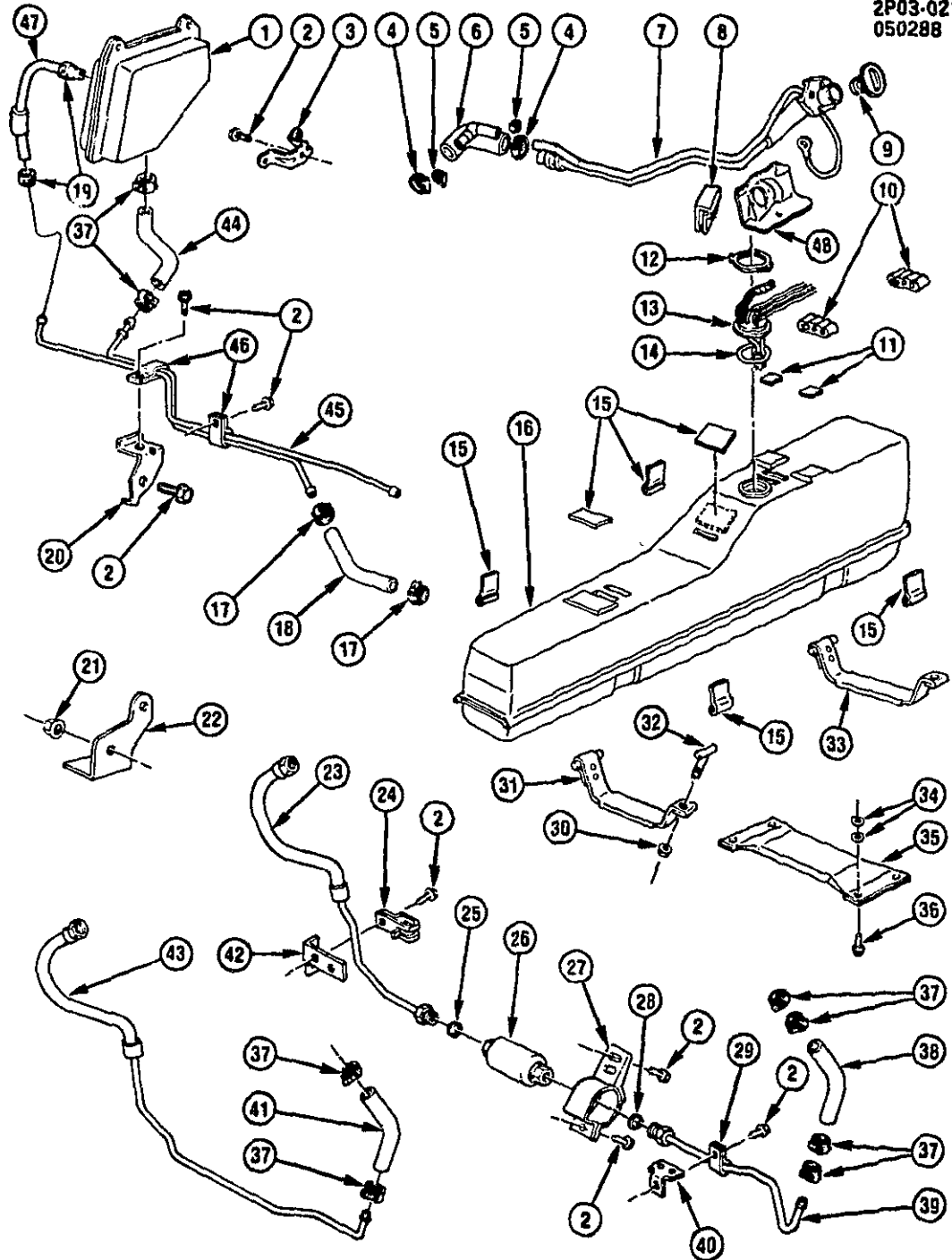

2P03-021

1987-1988 P FUEL SUPPLY SYSTEM

1.	A9	3.118	TANK, FUEL VAPOR	10041455
2.		8.977	BOLT, HWH TAP (M6 3X1 81X20)PZOR	12337628
3.	A9	3.118	BRACKET, FUEL VAPOR TANK	10041460
4.	N18	1.166	CLAMP, HEX HD WORM(33 3 TO 57 2M)(1987)	22518666
	N18	1.166	CLAMP, HEX HD WORM(33 3 TO 57 2M)(1988)	10056745
5.	N18	1.166	CLAMP, WORM TYPE (56"TO 1 06"DIA)	22518665
6.	A7	3.003	HOSE, FUEL TANK FIL & VENT	10026636
7.	A7	3.003	PIPE, FUEL TNK FIL (W/GRD STRAP)	10037635
8.	A7	3.008	INSULATOR, F/TNK FIL PIPE	10034610
9.	A7	3.028	CAP, W/HANDLE. FUEL TANK (GAS)	22525302
10.	A7	3.107	INSULATOR, FUEL SENDER PIPE	10026387
11.		N.S.	ANTI SQUEAK, F/TNK RR	
12.	A7	3.107	CAM, FUEL SENDER	22516548
13.	A7	3.107	SENDER, FUEL (IN TANK)(2 5R)	25093531
	B9	3.900	PUMP, FUEL (IN TANK)(EP1 25)(2 5R)	25115462
	A9	3.110	FILTER, FUEL (IN TANK)	25056455
	A7	3.107	METER, FUEL (2 8-9. 1988)	25093526
14.	A9	3.112	GASKET, FUEL METER (TANK UNIT)	3893118
15.		N.S.	INSULATOR, FUEL TANK	
16.	A7	3.001	TANK, FUEL	10041442
17.		8.948	CLAMP, WORM GEAR HEX SLOT SCREW (250 X 625) SS	25518880
18.	A9	3.145	HOSE, FUEL VAPOR TK FRT	10068766
19.		8.948	CLAMP, WORM GEAR HEX SLOT SCREW (250 X 625) SS	25518880
20.	A9	3.145	BRACKET, FUEL VPR PIPE CLIP (POS # 13)	10041688
21.	N20	2.251	NUT, HEX (M8 X 1 25 X 7 8)(W/CAST IRON HD)(0 334)	22521550
22.	A10	3.163	SHIELD, FUEL PIPE (2 8-9 W/C60. 1988)	10036499
23.	A10	3.163	HOSE, FUEL FEED	10068754
24.	A9	3.162	CLIP, FUEL FEED & RTN PIPE (2 5R)	10042838
25.		N.S.	SEAL, FUEL FILTER O RING	
26.	B9	3.890	FILTER, FUEL (TYPE GF481)	25055052
27.	B9	3.890	CLAMP, TBI FUEL FILTER	10039217
28.		N.S.	SEAL, FUEL FLITER O RING	
29.	C11	4.128	CLIP, FUEL PIPE	22518924
30.		8.917	NUT, HEX TORQ PREV (M8X1 25) 10 CAD	11500780
31.	A7	3.022	STRAP, F/TK FRT	
32.	A7	3.023	BOLT, F/TNK STRP TO UNDER BODY T-BOLT)	10040191
33.	A7	3.022	STRAP, F/TK RR	10064931
34.		8.929	WASHER, FL SEALING (16X 75X 12) RUB PL	7583551
35.	N28	12.981	REINFORCEMENT, FLR PAN AT F/TNK	20619749
36.		8.900	BOLT, HEX FLGD (M8X1 25X16) 9 8 PC	11507022
37.		8.948	CLAMP, WORM GEAR HEX SLOT SCREW (250 X 625) SS	25518880
38.		8.962	HOSE, FUEL (3/8"X24")(*1)	9438373
39.	A10	3.163	PIPE, FUEL FEED	10039223
40.	A9	3.162	BRACKET, FUEL FEED FRT PIPE (POS #8)	10034781
41.		8.962	HOSE, FUEL (5/16X25 FT)(*1)	9439550
42.	A9	3.162	BRACKET, FUEL FEED & RTN HOSE LWR (POS#10)	10036173
43.	A10	3.163	HOSE, FUEL RTN (ENG PIPE TO SENDER)O/RG (2 8-9)	10039222
44.	A9	3.145	HOSE, FUEL VAPOR TK RR	10041463
45.		N.S.	PIPE, FUEL EXPANSION TANK	
		8.984	TUBING, BULK (5/16"OD X25')	1324714
46.	A9	3.162	CLIP, FUEL VAPOR PIPE	14020587
47.	A9	3.145	HOSE, FUEL VAPOR INTER	10041464
48.	A7	3.003	PLATE, F/TNK FIL PIPE ATCH-LH (W/GASKET)	20534622

NOTE 1 CUT TO SIZE FROM BULK HOSE

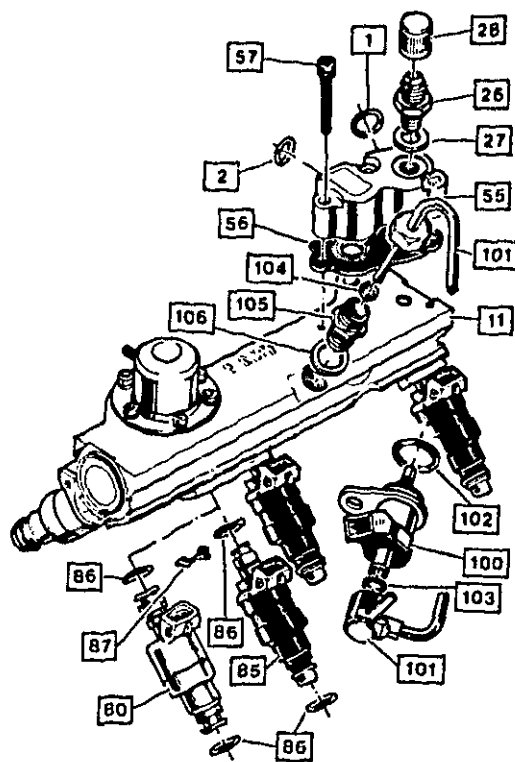

XV 144

GM03-142

1985-1988 P FUEL INJECTOR RAIL MPFI (MODELS F6A,R610) (L44/2.8-9)

1.	A10	3.163	SEAL, FUEL FEED PIPE O-RING
2.	A10	3.163	SEAL, FUEL RTN PIPE O-RING
11.		N.S.	FUEL RAIL & PRESS REGULATOR ASM(*1)
26.		N.S.	FUEL PRESSURE CONNECTION ASM(*2)
27.		N.S.	SEAL, FUEL PRESSURE CONN ASM(*2)
28.		N.S.	CAP, FUEL PRESSURE CONN ASM(*2)
55.		N.S.	FUEL BLOCK(*3)
56.		N.S.	SEAL, FUEL BLOCK(*3)
57.		N.S.	SCREW ASM, FUEL BLOCK ATCH
80.		N.S.	MULTEC FUEL INJECTOR ASM(*4)
85.		N.S.	BOSCH FUEL INJECTOR ASM(*5)
86.	A12	3.331	O RING, FUEL INJECTOR(*2,3)
87.	A11	3.302	CLIP, INJECTOR RETAINER(*4,5,7)
100.		N.S.	VALVE, COLD START(*8)
101.		N.S.	TUBE & BODY ASM, COLD START VLV(*9)
102.		N.S.	O-RING SEAL, VALVE(*8,9,10)
103.		N.S.	O-RING SEAL, BODY(*8,9,10)
104.		N.S.	O-RING SEAL, TUBE(*1,8,9,10)
105.	A11	3.329	FITTING KIT, COLD START VLV (INCL 106)
106.		N.S.	SEAL, COLD START FITTING (PART OF 105)(*9)

- NOTE 1 GROUP 3 330 RAIL KIT. W/PRESS REG FUEL (INCLS #11 104)
 NOTE 2 GROUP 3 330 CONNECTION KIT. FUEL PRESS (INCLS #26 27 28)
 NOTE 3 GROUP 3 330 BLOCK KIT FUEL INL/OTLT (INCLS #55,56 57)
 NOTE 4 GROUP 3 300 INJECTOR KIT FUEL (MULTEC)(INCLS #80 86 87)
 NOTE 5 GROUP 3 300 INJECTOR KIT FUEL (BOSCH)(INCLS #85 86,87)
 NOTE 7 GROUP 3 302 CLIP KIT INJ RET (INCLS #87 QTY 5)
 NOTE 8 GROUP 3 329 VALVE KIT COLD START (INCLS #100 102 103 104)
 NOTE 9 GROUP 3 329 TUBE KIT COLD START (INCLS #101 102 103 104 106)
 NOTE 10 GROUP 3 329 O-RING KIT COLD START VLV (INCLS #102 103 104)

GM03-111
040286

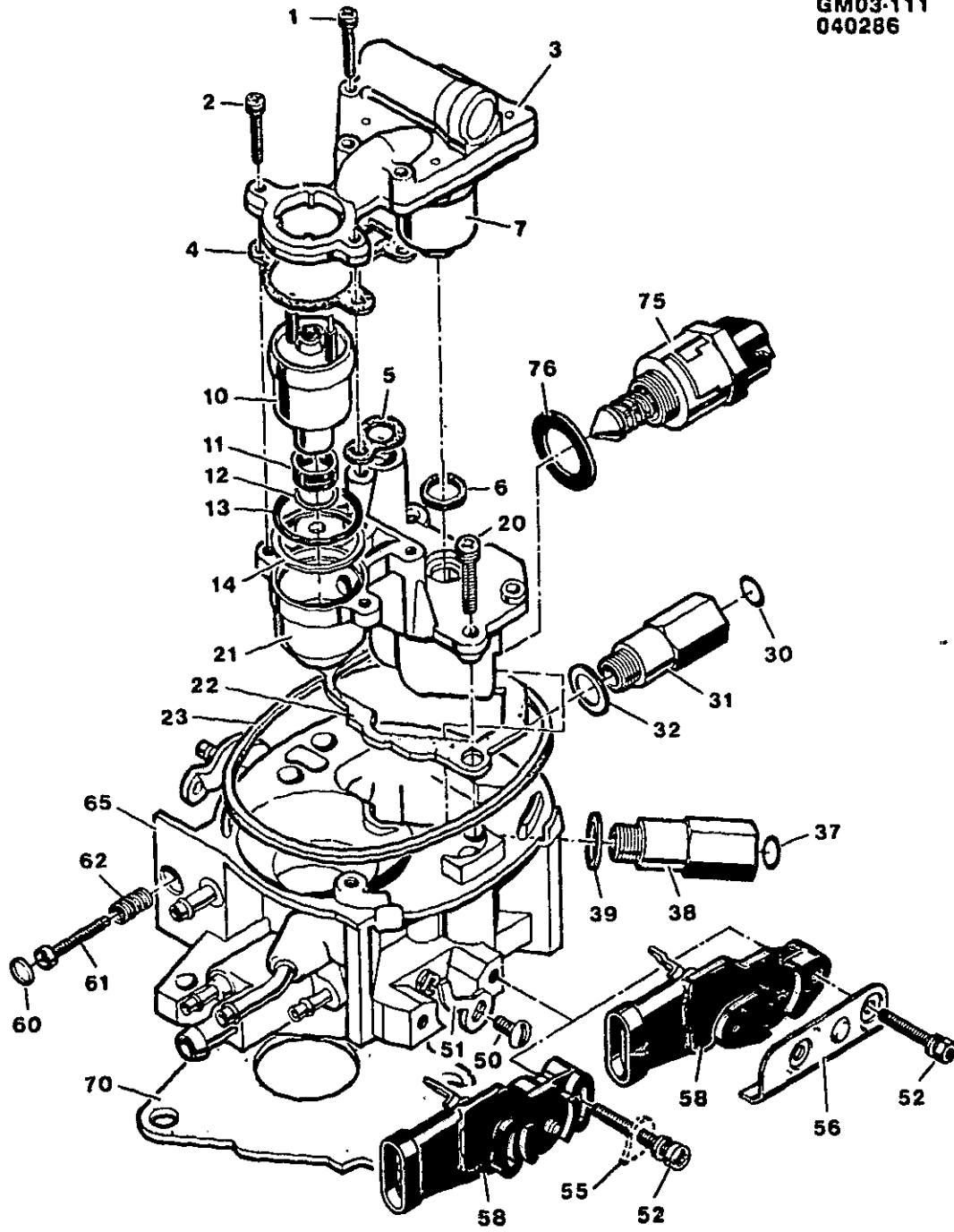

GM03-111

1984-1986 P THROTTLE BODY/TBI (MODEL 300)

1.	N.S.	SCREW ASM, FUEL METER COVER ATTACHING-LONG(*3 8)
2.	N.S.	SCREW ASM, FUEL METER COVER ATTACHING-SHORT(*3 8)
3.	N.S.	FUEL METER COVER ASM>(*3.11)
4.	N.S.	GASKET, FUEL METER COVER(*2 3.4 12 13)
5.	N.S.	GASKET, FUEL METER OUTLET(*2 3.4 12 13)
6.	N.S.	SEAL, PRESSURE REGULATOR(*2 3.4 12 13)
7.	N.S.	PRESSURE REGULATOR>(*3.11)
10.	N.S.	INJECTOR, FUEL(*3 4.13)
11.	N.S.	FILTER, FUEL INJECTOR INLET(*3.4.12)
12.	N.S.	O-RING, FUEL INJECTOR-LOWER(*2.3.4.12.13)
13.	N.S.	O-RING, FUEL INJECTOR-UPPER(*2.3.4.12.13)
14.	N.S.	WASHER, FUEL INJECTOR(*2.3.4.12.13)
20.	N.S.	SCREW ASM, FUEL METER BODY ATTACHING(*8)
21.	N.S.	FUEL METER BODY ASM>(*3.10)
22.	N.S.	GASKET, THROTTLE BODY TO FUEL METER BODY(*2 3)
23.	A20	3.403 GASKET, AIR CLEANER(*1.2)
30.	A10	3.163 O-RING, FUEL RETURN LINE
31.	N.S.	NUT, FUEL OUTLET(*7)
32.	N.S.	GASKET, FUEL OUTLET NUT(*2.3 7)
37.	A10	3.163 O-RING, FUEL FEED LINE
38.	N.S.	NUT, FUEL INLET(*7)
39.	N.S.	GASKET, FUEL INLET NUT(*2.3 7)
50.	N.S.	SCREW, THROTTLE LEVER ATCH(*5.6 8)
51.	N.S.	LEVER, THROTTLE POSITION SENSOR(*5.6 8)
52.	N.S.	SCREW ASM, SENSOR ATCH(*5.6 8)
55.	N.S.	RETAINER, SENSOR(*5.6 8)
58.	A23	3.671 SHIELD KIT, EGR VLV TO TPS (INCLS #52)
58.	N.S.	SENSOR, THROTTLE POSITION(*6)
60.	N.S.	PLUG, IDLE STOP SCREW(*5)
61.	N.S.	SCREW ASM, IDLE STOP(*5.8)
62.	N.S.	SPRING, IDLE STOP SCREW(*5.8)
65.	N.S.	THROTTLE BODY ASM>(*5)
70.	B8	3.726 INSULATOR, THROTTLE BODY TO INT MANIF(*1.2)
75.	N.S.	VALVE ASM, IDLE AIR CONTROL(*9)
76.	N.S.	GASKET, IDLE AIR CONTROL VALVE ASM(*2.9)

NOTE 1 GROUP 3 725 THROTTLE BODY INJECTION (SERVICE) INCLS ALL ITEMS ILLUSTRATED

NOTE 2 GROUP 3 724 GASKET KIT-INCLS #4.5.6.12.13.14.22.23.32.39.70.76

NOTE 3 GROUP 3 734 FUEL METER KIT-INCLS #1.2.3.4.5.6 7.11.12 13.14.20.21 22.32.39

NOTE 4 GROUP 3 774 FUEL INJECTOR KIT-INCLS #4.5.6.10.11.12.13.14

NOTE 5 GROUP 3 729 BODY KIT, THROTTLE-INCLS #50.51.52.55.60.61.62.65

NOTE 6 GROUP 3 764 SENSOR KIT, THROTTLE POSITION-INCLS #50.51.52.55 58

NOTE 7 GROUP 3 724 FUEL INLET & OUTLET KIT-INCLS #31.32 38.39

NOTE 8 GROUP 3 724 FASTENER ASSORT KIT-INCLS #1.2.20.50 51 52 55

NOTE 9 GROUP 3 820 CONTROL KIT, IDLE AIR VALVE-INCLS #75.76

NOTE 10 GROUP 3 734 FUEL METER BODY KIT-INCLS #21

NOTE 11 GROUP 3 734 FUEL METER COVER KIT-INCLS #3 7

NOTE 12 GROUP 3 774 FILTER & GASKET KIT, FUEL METER-INCLS #4 5 6 11.12.13 14

NOTE 13 GROUP 3 774 FUEL INJECTOR KIT (REMAN)-INCLS #4.5 6.10.11.12.13.14

GM03-146
102084

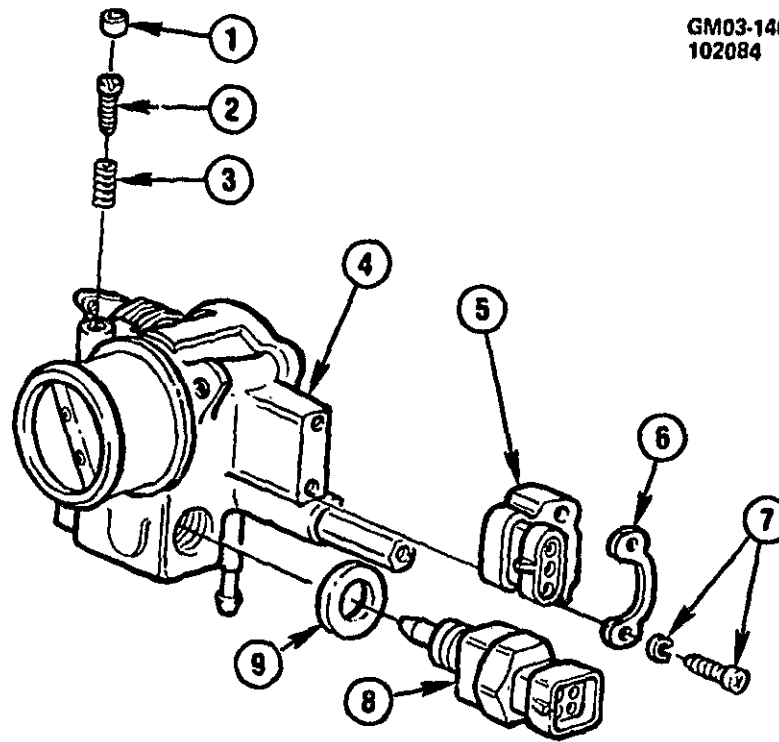

GM03-146

1985-1988 P THROTTLE BODY/MPFI L44/2.8-9

NOTE THROTTLE BODY ASM (SEE CHART IN GROUP 3 33F FOR USAGE)

NOTE FITTING KIT (SEE CHART IN GROUP 3 335 FOR USAGE)

NOTE O-RING KIT (SEE CHART IN GROUP 3 335 FOR USAGE)

1.	A17	3.338	PLUG, CUP	10031266
2.	A17	3.338	SCREW, IDLE ADJ	10031266
3.	A17	3.338	SPRING, IDLE ADJ SCREW (3 761)	2285846
4.	A12	3.335	BODY KIT, W/TUBES	10037718
5.	A17	3.339	SENSOR KIT, THROTTLE (INCLS ITEM #6, 7)	10108063
6.	A17	3.339	RETAINER, TPS (PART OF ITEM #5)	10031269
7.	A17	3.339	SCREW, W/WASHER TPS (PART OF ITEM #5)	17071825
8.	A17	3.338	VALVE KIT, IDLE AIR CONTROL (INCLS ITEM #9)	1711288
9.	A17	3.338	GASKET, IDLE AIR CONTROL (PART OF ITEM #8)	10031267

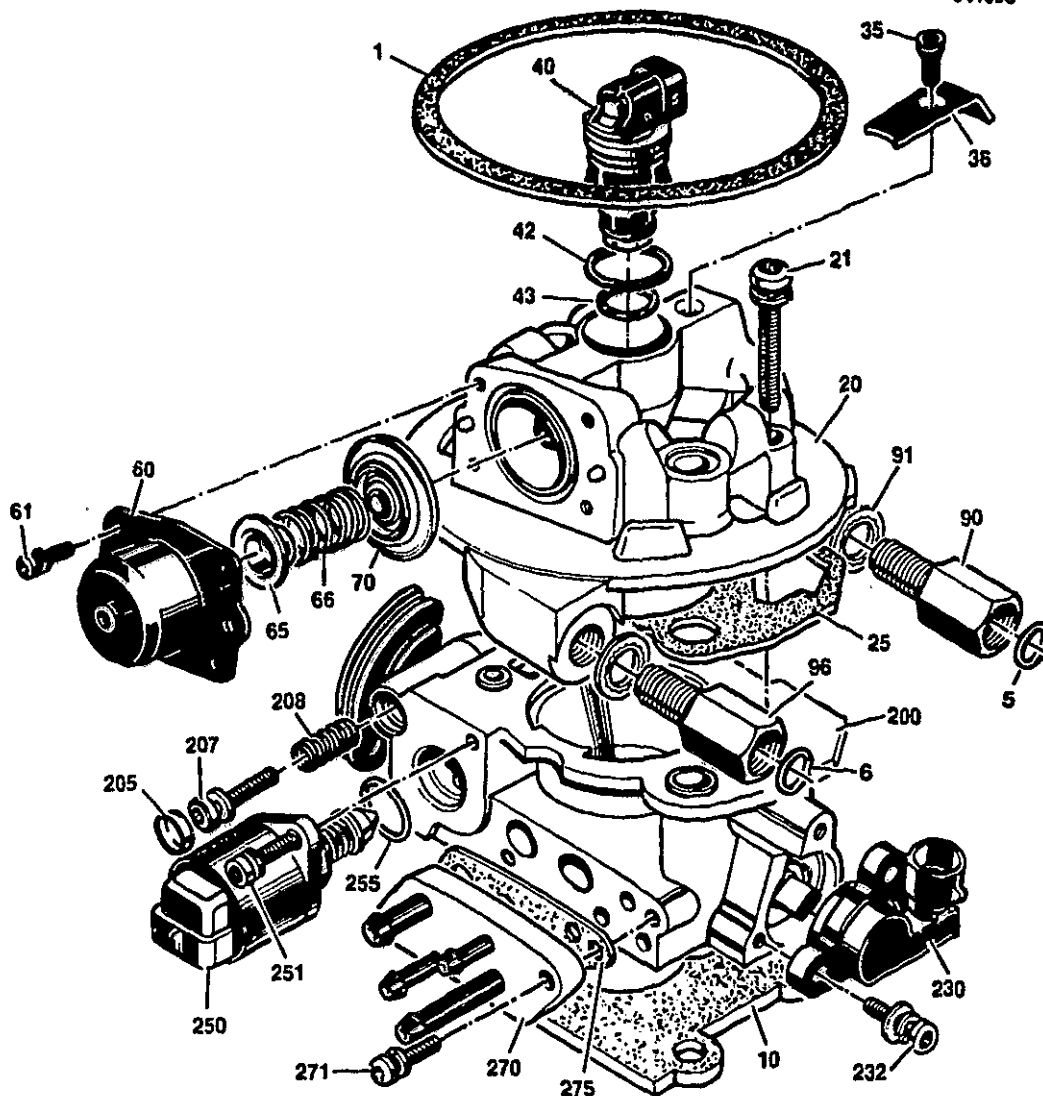

GM03-185B

1987-1988 P THROTTLE BODY/TBI (MODEL 700)(LR8/2.5R)

- 1. A20
- 5. A10
- 6. A10
- 10. 88
- 20. N.S.
- 21. N.S.
- 25. N.S.
- 35. N.S.
- 36. N.S.
- 40. N.S.
- 42. N.S.
- 43. N.S.
- 60. N.S.
- 61. N.S.
- 65. N.S.

- 3.403
- 3.163
- 3.163
- 3.726
- N.S.
- N.S.
- N.S.
- N.S.
- N.S.
- N.S.
- N.S.
- N.S.
- N.S.
- N.S.
- N.S.

- GASKET, AIR CLEANER(*KIT1.KIT2.KIT4)
- SEAL, FUEL FEED PIPE O-RING(*KIT1.KIT2.KIT4)
- SEAL, FUEL RTN PIPE O-RING(*KIT1.KIT2.KIT4)
- GASKET, TBI
- FUEL METER ASM>(*KIT1.KIT8)
- SCREW, FUEL METER BODY-THROTTLE BODY ATTACH(*KIT1.KIT10)
- GASKET, METER BODY TO THROTTLE BODY(*KIT1.KIT2.KIT4.KIT8)
- SCREW, INJECTOR RETAINER(*KIT1.KIT8)
- RETAINER, INJECTOR(*KIT1.KIT8 KIT10)
- INJECTOR, FUEL(*KIT1.KIT3 KIT8)
- O-RING, FUEL INJECTOR-UPPER(*KIT1.KIT2.KIT3.KIT4.KIT8)
- O-RING, FUEL INJECTOR-LOWER(*KIT1.KIT2.KIT3.KIT4.KIT8)
- COVER ASM, PRESSURE REGULATOR(*KIT1.KIT8)
- SCREW, PRESSURE REGULATOR ATCH(*KIT1.KIT8 KIT10)
- SEAT, SPRING(*KIT1.KIT8)

22514722
22516256
10086805

86.	N.S.	SPRING, PRESSURE REGULATOR(*KIT1 KIT8)
70.	N.S.	DIAPHRAGM ASM, PRESSURE REGULATOR(*KIT1.KIT2 KIT4 KIT8)
90.	N.S.	NUT, FUEL INLET(*KIT1.KIT7.KIT8)
91.	N.S.	SEAL, FUEL NUT(*KIT1.KIT2.KIT4.KIT7.KIT8)
96.	N.S.	NUT, FUEL OUTLET(*KIT1.KIT7)
200.	N.S.	THROTTLE BODY ASM>(*KIT1.KIT4)
205.	N.S.	PLUG, IDLE STOP SCREW(*KIT1)
207.	N.S.	SCREW & WASHER ASM, IDLE STOP(*KIT1 KIT4)
208.	N.S.	SPRING, IDLE STOP SCREW(*KIT1.KIT4)
230.	N.S.	SENSOR, THROTTLE POSITION(*KIT1,KIT5)
232.	N.S.	SCREW & WASHER ASM, TPS ATCH(*KIT1.KIT10)
250.	N.S.	VALVE, IDLE AIR CONTROL (IACV)(*KIT1.KIT6)
251.	N.S.	SCREW, IDLE AIR CONTROL VALVE ATCH(*KIT1,KIT10)
255.	N.S.	O-RING, IDLE AIR CONTROL VALVE(*KIT1.KIT2.KIT4.KIT6)
270.	N.S.	TUBE MODULE ASM>(*KIT1.KIT9)
271.	N.S.	SCREW ASM, TUBE MODULE ASM(*KIT1.KIT10)
275.	N.S.	GASKET, TUBE MODULE ASM(*KIT1.KIT2.KIT4 KIT9)

SERVICE KITS

1.	A27	3.725	THROTTLE BODY INJ.(T B I) INCL #1.275(LESS #10)	17111908
2.	A27	3.724	GASKET KIT, INCL #1.5.6.25.42.43.70.91.255.275	17076153
3.	88	3.774	FUEL INJECTOR KIT, INCL #40.42.43	17111988
4.	88	3.729	BODY KIT, THROTTLE, INCL #1.5.6.25.42.43.70.91.200.207.208.255.275	17111911
5.	88	3.764	SENSOR KIT, THROTTLE POSITION- INCL #230	17111822
6.	88	3.820	CONTROL KIT, IDLE AIR- INCL #250.255	17111826
7.	A27	3.724	NUT KIT, FUEL INLET & OUTLET- INCL #90.91.96	17111818
8.	88	3.734	FUEL METER BODY KIT, INCL #20.25.35.36.40.42.43.60.61.65.66.70.90. 91	17111989
9.	88	3.734	COVER KIT, 4-VACCUUM PORT- INCL #270.275	17111915
10.	88	3.734	FASTENER ASSORTMENT KIT, INCL #21.36.61.232.251.271	17111819

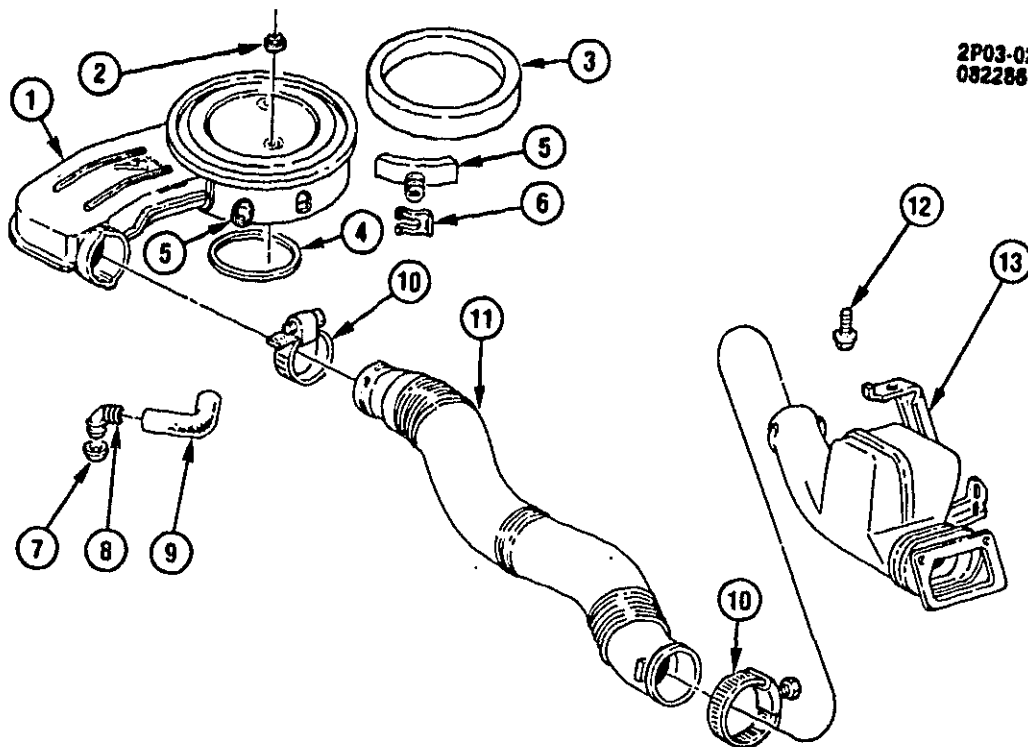

2P03-022

1987-1988 P AIR INTAKE SYSTEM-L4 (LR8/2.5R)

1.	A17	3.402	AIR CLEANER, ENG	25098335
2.	A20	8.917	NUT, HFH (M8X1 25X7 5) 10 PEOR	11507038
3.	A20	3.410	ELEMENT, A/CL (POLYWRAP(A913C)	25043317
4.	A20	3.403	GASKET, A/CL	10042945
5.	A20	3.410	BREATHER, A/CL AND SIL (FB-82)	25041487
6.	N19	1.745	RETAINER, MAP (U-SHAPED STL 1 64X1 25)	22530004
7.	N19	1.745	GROMMET, CR/CASE VENT TO RKR ARM CVR	10037287
8.	N19	1.762	FITTING, C/CASE VENT	10021028
9.	N19	1.762	HOSE, CR/CASE VENT	10043061
10.	A20	3.417	CLAMP, AIR INT DUCT RR	14088928
11.	A20	3.417	DUCT, AIR INT RR	10044265
12.	A20	8.977	BOLT, HWH (M6 3X1 81X20)	12337828
13.	A20	3.417	DUCT, FRT AIR INT (WATER SEPERATION)	10044264

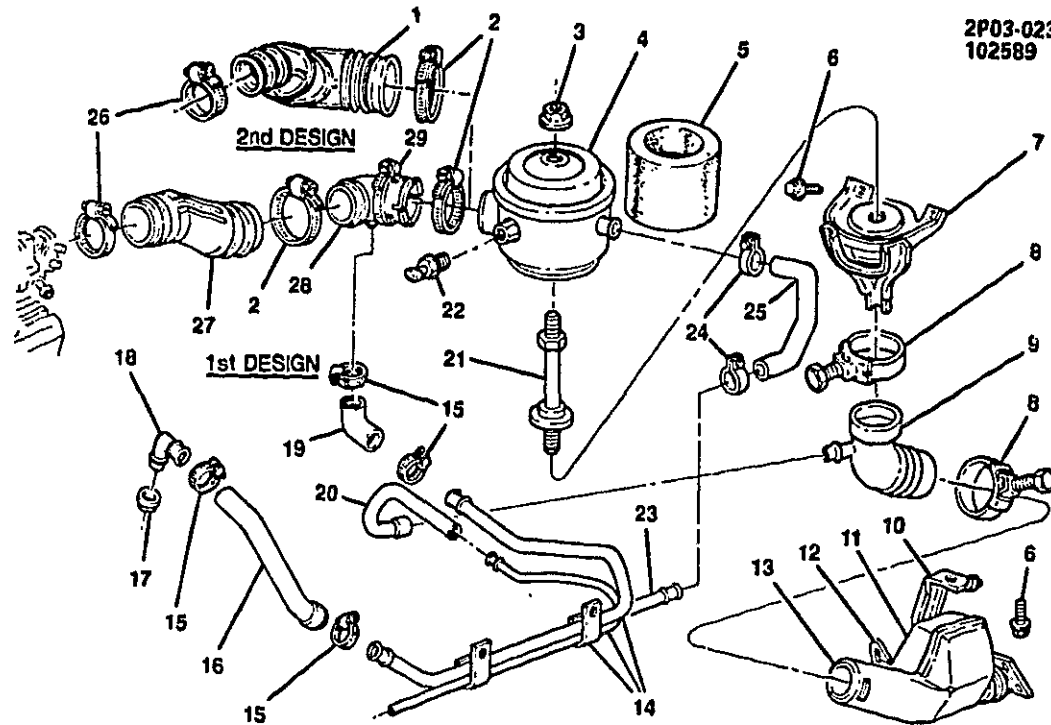

2P03-023

1985 P AIR INTAKE SYSTEM-V6 (L44/2.8-9)

1.	A20	3.417	DUCT, THROT BODY TO ADAPT (2ND DSGN)	10154781
2.		3.407	CLAMP, AIR INT DUCT RR (1 166)	10040194
3.	A20	3.403	NUT, A/CLNR LRG HEX FLG (M6X1) STL	10031019
4.	A17	3.402	AIR CLEANER, ENG (1ST DSGN)	25043488
	A17	3.402	AIR CLEANER, ENG (2ND DSGN)	25095512
5.	A20	3.410	ELEMENT, A/CLNR PAPER (A925C)	25043504
6.		8.977	BOLT, HWH (M6.3X1 81X20) PZOR	12337828
7.	A20	3.406	SUPPORT, A/CLNR	10033705
8.	A20	3.417	CLAMP, AIR INT DUCT RR	14088928
9.	A20	3.417	DUCT, A/CLNR TO AIR INT DUCT	10042033
10.	A20	3.417	BRACKET, FRT AIR INT DUCT UP	10030451
11.	A20	3.417	DUCT, FRT AIR INT (WATER SEPARATION)	10044264
12.	A20	3.417	BRACKET, FRT AIR INT DUCT LWR	10030452
13.	A20	3.417	DUCT, FRT AIR INT TO QTR PNL	10030240
14.	N19	1.762	TUBE, CR/CASE VENT TO F/D (1ST DSGN)	10038326
15.		8.948	CLAMP, WORM GR (62 TO 1 25)	12337891
16.		N.S.	HOSE, CR/CASE VENT TUBE TO CONN	
17.	N19	1.745	GROMMET, CR/CASE VENT TUBE CONN TO RKR ARM CVR	10137083
18.		N.S.	CONNECTOR, CR/CASE VENT T'UBE TO RKR ARM CVR FRT GROM	
19.		N.S.	HOSE, CR/CASE VENT TUBE TO A/CLNR DUCT (1ST DSGN)	
20.		8.962	HOSE, FUEL OIL EVAP (1/4)"(1)	9438257
21.	A20	3.403	STUD, A/CLNR TO SUPT	10033095
22.	A24	3.882	SENSOR, MANIF AIR TEMP	25036751
23.	N19	1.762	TUBE, CR/CASE VENT TO F/D (2ND DSGN)	10041473
24.		8.948	CLAMP, WORM GR (1 1/16 TO 1 5/16)(2ND DSGN)	1470030
25.		N.S.	HOSE, CR/CASE VENT TUBE (2ND DSGN)	
26.		8.948	CLAMP, WORM GR (52 4 TO 74MM) SST	10041052
27.	A20	3.417	DUCT, THROT BODY TO ADAP (1ST DSGN)	10154784
28.		N.S.	ADAPTER, AIR INT DUCT (1ST DSGN)	
29.		8.948	CLAMP, HEX HD WORM GR (1 0 TO 6 0)(1ST DSGN)	3749810

NOTE 1 CUT TO SIZE FROM BULK HOSE

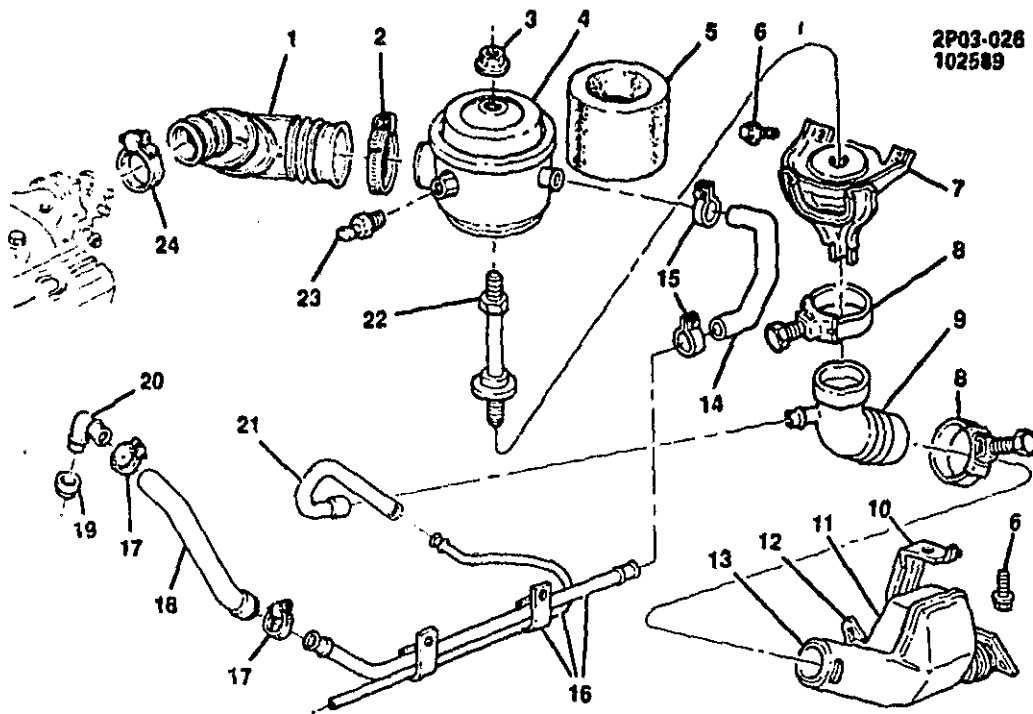

2P03-026
102589

2P03-026

1986-1988 P AIR INTAKE SYSTEM-V6 (L44/2.8-9)

1.	A20	3.417	DUCT, THROT BODY TO ADAPT	10154781
2.		3.407	CLAMP, AIR INT DUCT RR	10040194
3.	A20	3.403	NUT, A/CLNR LRG HEX FLG (M6X1)	10031019
4.	A17	3.402	AIR CLEANER, ENG	25095512
5.	A20	3.410	ELEMENT, A/CLNR PAPER (A925C)	25043504
6.		8.977	BOLT, SEMS HEX W/FL WA (M6 3X1 81X20) 6010M PZOR	12337828
7.	A20	3.405	SUPPORT, A/CLNR	10033705
8.	A20	3.417	CLAMP, AIR INT DUCT RR	14086928
9.	A20	3.417	DUCT, A/CLNR TO AIR INT DUCT	10042033
10.	A20	3.417	BRACKET, AIR INT DUCT UPR	10030451
11.	A20	3.417	DUCT, FRT AIR INT (WATER SEPARATION)	10044284
12.	A20	3.417	BRACKET, FRT AIR INT DUCT LWR	10030452
13.	A20	3.417	DUCT, FRT AIR INT TO QTR PNL	10030240
14.		N.S.	HOSE, CR/CASE VENT TUBE TO A/CL	
15.		8.948	CLAMP, WORM GR (11/16 TO 1 5/16)	1470030
16.	N19	1.782	TUBE, CR/CASE VENT TO F/D	10041473
17.		1.760	CLAMP, WORM GR (62 TO 1 25) CR/CASE VENT TUBE HOSE	12337891
18.		N.S.	HOSE, CR/CASE VENT TUBE TO CONN	
19.	N19	1.745	GROMMET, CR/CASE VENT TUBE CONN TO RKR ARM CVR	10137063
20.		N.S.	CONNECTOR, CR/CASE VENT TUBE TO RKR ARM CVR FRT GROM	
21.		8.982	HOSE, FUEL OIL EVAP (1/4" * 1)	9438257
22.	A20	3.403	STUD, A/CLNR TO SUPT	10033695
23.	A24	3.682	SENSOR, A/CLNR AIR TEMP	25036751
24.		8.948	CLAMP, WORM GR (52 4 TO 74MM) SST	10041052

NOTE 1 CUT TO SIZE FROM BULK HOSE

2P03-001
061083

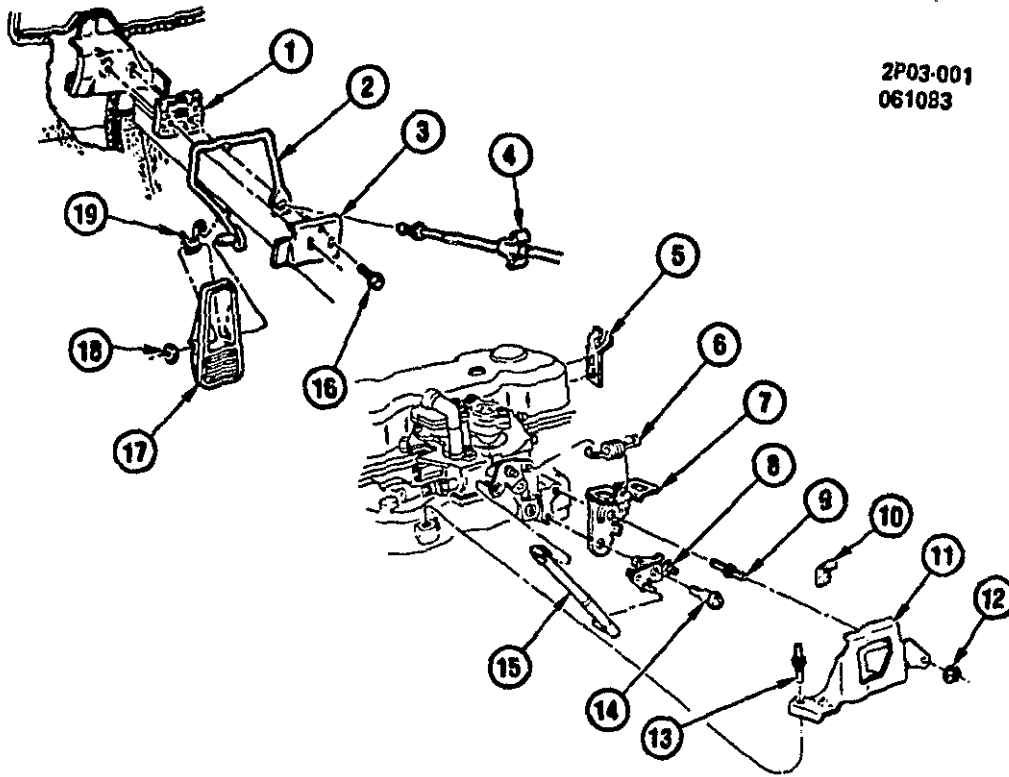

2P03-001

1984-1985 P ACCELERATOR CONTROL-L4 (LR8/2.5R)

1.	A21	3.454	SUPPORT, ACCEL PED LVR	10031637
2.	A21	3.431	LEVER, ACCEL PED	10029578
3.	A21	3.454	PLATE, ACCEL PED LVR	10031838
4.	A20	3.430	CABLE, ACCEL CONT (1984)	10033890
	A20	3.430	CABLE, ACCEL CONT (1985)	10041509
5.	A21	3.489	RETAINER, ACCEL CONT CBL	10029080
6.	A21	3.459	SPRING, THROT RTN (1984)	10029602
7.	A21	3.454	BRACKET, THROT & TRAN TV CBL (1984)	10026073
8.	A21	3.454	LEVER, THROT CONT IDLER	10029188
9.	A11	3.275	BOLT, BRKT TO INT MANIF (M10X1 5X56 5)(1984)(1 252)	15596518
10.	A20	3.425	RETAINER, 5/32" CABLE (8 821)	15667924
11.	A21	3.454	PROTECTOR, THROT LVR (1984)	10038672
12.		8.915	NUT, HEX (M10 X 1 5 X 9)	
13.	N18	1.857	STUD, HEX HD PLT TO CYL BLK (0 208) (1984)	10018812
14.	A21	3.454	BOLT, THROT CONT IDLER LVR	10020587
15.	A21	3.454	LINK, THROT CONT (1985)	10030853
16.		8.977	SCREW, HWH (1/4" - 14 X 1 1 2")	
17.	A21	3.451	PEDAL, ACCEL	14105684
18.		8.921	NUT, PUSH-ON (SELFLOCK EXT RET 1 4")	
19.	A21	3.459	SPRING, ACCEL PED	10026507

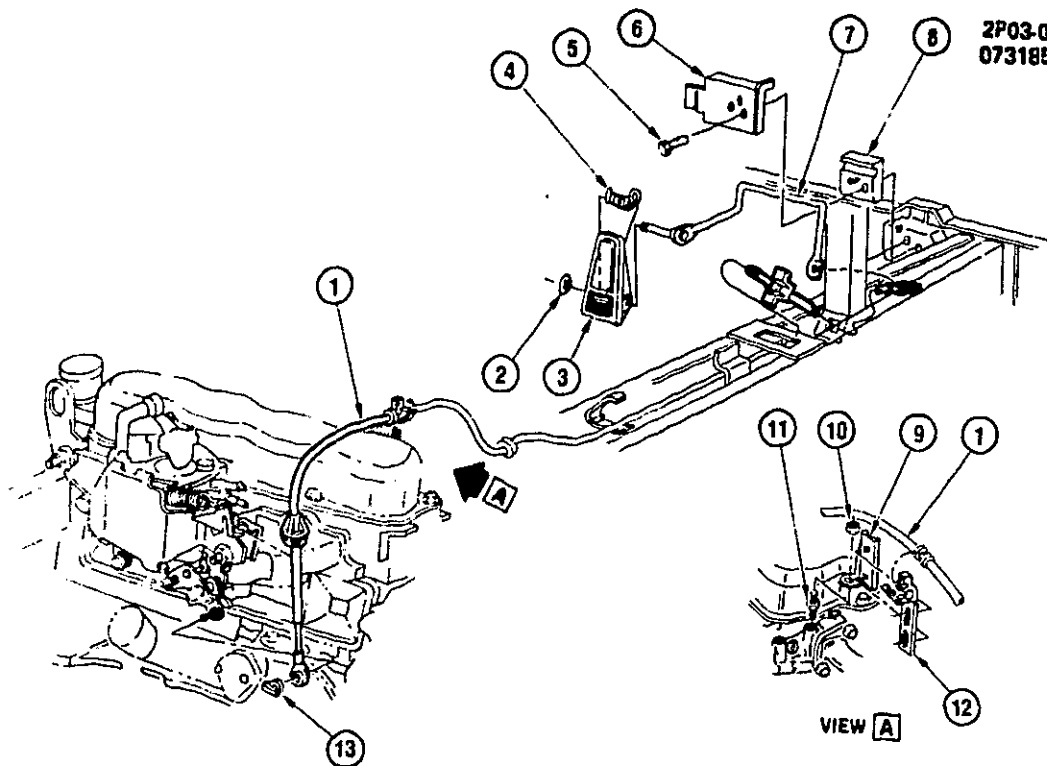

2P03-016

1986 P ACCELERATOR CONTROL-L4 (LR8/2.5R)

1.	A20	3.430	CABLE, ACCEL CONT	
2.		8.921	NUT, PUSH-ON (SELFLOCK EXT RET 1/4")	10041509
3.	A21	3.451	PEDAL, ACCEL	
4.	A21	3.459	SPRING, ACCEL PED	14105864
5.		8.977	SCREW, HEX (M6 3X1 81X40)	10026507
6.	A21	3.454	PLATE, ACCEL PED LVR	
7.	A21	3.431	LEVER, ACCEL PED	10031636
8.	A21	3.454	SUPPORT, ACCEL PED LVR	10029576
9.	N20	2.183	BRACKET, ACCEL CONT CBL RET(2 183)	10031637
10.		8.917	NUT, HEX (M8X1 25)	10028846
11.	N13	0.004	STUD, ACCEL CONT CBL RET BRKT	25517778
12.	A21	3.469	RETAINER, ACCEL CONT CBL	10029080
13.	A20	3.425	RETAINER, 5/32" CABLE (8 821)	15567924

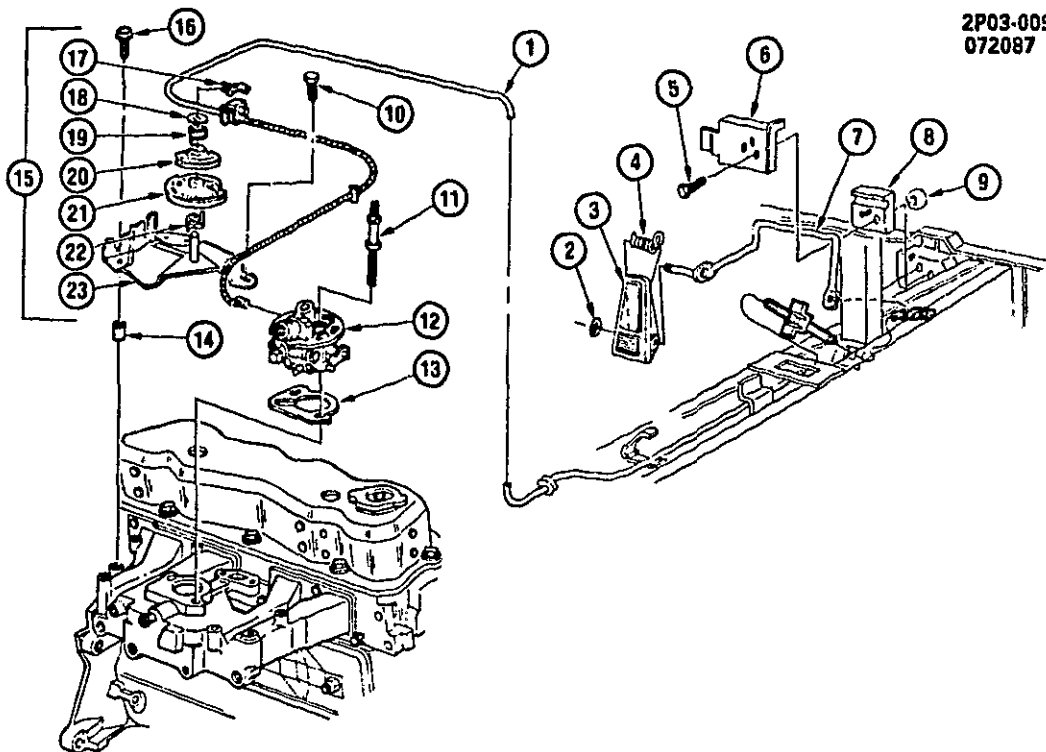

2P03-009

1987-1988 P ACCELERATOR CONTROL-L4 (LR8/2.5R)

1.	A20	3.430	CABLE, ACCEL CONT (MT2)	10041795
	A20	3.430	CABLE, ACCEL CONT (MD9 EXC K34)	10046806
	A20	3.430	CABLE, ACCEL CONT (MD9.K34)	10046607
	A20	3.430	CABLE, ACCEL CONT (MT2 EXC K34)	10046808
	A20	3.430	CABLE, ACCEL CONT (MT2.K34)	10046809
2.		8.921	NUT, PUSH-ON (SELFLOCK EXT RET 1/4") PHOS	3909063
3.	A21	3.451	PEDAL, ACCEL	14105664
4.	A21	3.459	SPRING, ACCEL PED	10028507
5.		8.977	SCREW, HWH TAP (M6 3X1 81X40) ZC	11508027
6.	A21	3.454	PLATE, ACCEL PED LVR	10031836
7.	A21	3.431	LEVER, ACCEL PED	10029576
8.	A21	3.454	SUPPORT, ACCEL PED LVR	10031837
9.		8.921	RETAINER, PUSH-ON (M6 3X1) PHOS	11502672
10.		8.900	BOLT, HFH (M8X1 25X20) 10 9 POR	11514343
11.		N.S.	STUD, TBI (164 9 MM TL)	
12.	A27	3.725	THROTTLE BODY INJ	17111906
13.	B8	3.726	GASKET, TBI	10066805
14.	A21	3.454	SPACER, THROT MOD SYS BRKT	10044708
15.		N.S.	BRACKET, ACCEL CONT CBL	
16.	A21	3.454	BOLT, ACCEL CONT CBL BRKT TO INT MANIF (M8X1 25X20)	10035352
17.	A21	3.469	CLIP, THROT PULLEY MOD	10029893
18.	B8	3.880	WASHER, CRCONT SERVO CBL PULLEY	10041790
19.	B8	3.880	SPRING, CRCONT SERVO CBL PULLEY	10041799
20.	B8	3.880	PULLEY, CRUISE CONT SERVO CBL	10041798
21.	A21	3.454	PULLEY, THROT IDL (W/A.T)	10041788
	A21	3.454	CAM, THROT MOD (W/M.T)	10041796
22.	A21	3.459	SPRING, THROT MOD (TMS IDLER)(W/A.T ONLY)	10044141
23.	A21	3.452	BRACKET, THROTTLE MOD SYSTEM	10041784

2P03-014
020785

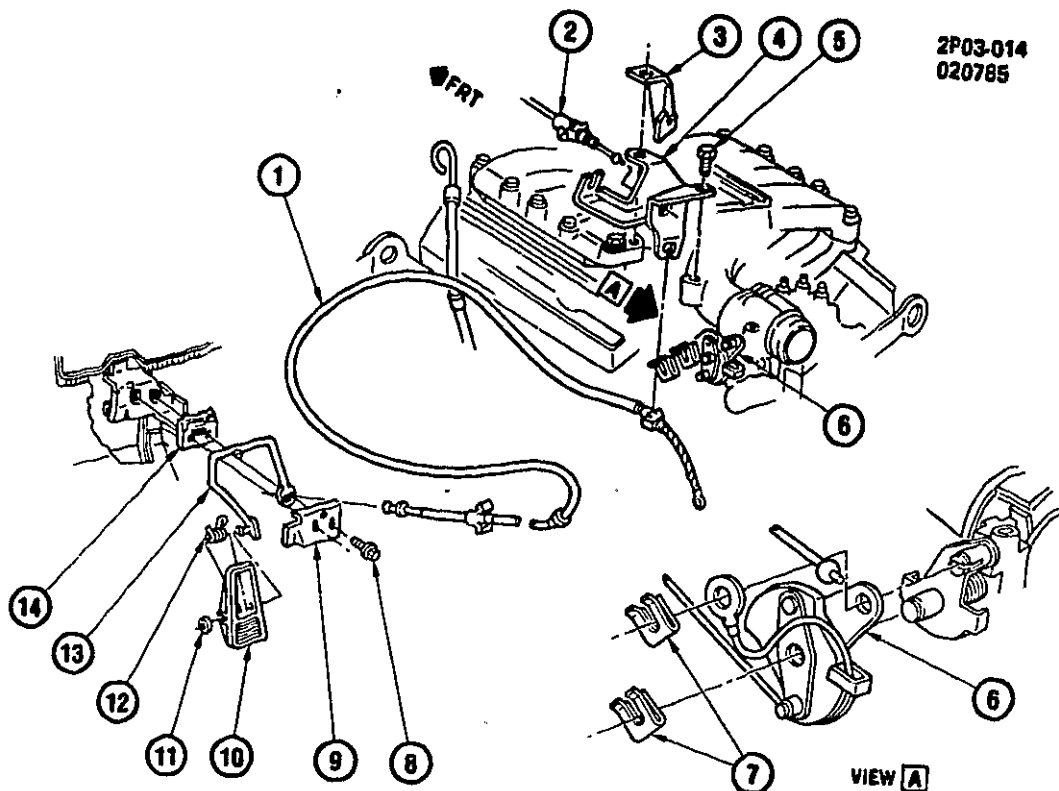

2P03-014

1985-1988 P ACCELERATOR CONTROL-V6 (L44/2.8-9)

1.	A20	3.430	CABLE, ACCEL CONT (1985-86)	10054255
	A20	3.430	CABLE, ACCEL CONT (1987)	10046805
2.	C11	4.050	CABLE, TRANS THROT VLV	10042208
3.	N20	2.257	SUPPORT, SPLG WIRE	10035907
4.	A21	3.454	BRACKET, ACCEL CONT CBL TV & CRUISE CONT	10036887
5.	A21	3.454	BOLT, ACCEL CONT CBL BRKT TO INT MANIF	10035352
6.	A21	3.454	LEVER, ACCEL CONT-W/A.T (MD9)	10033141
	A21	3.454	LEVER, ACCEL CONT-W/M.T (W/M T.)	10033145
7.	A21	3.489	CLIP, ACCEL CONT CBL TO TBA DRIVE PIN	10029893
8.		8.900	SCREW, HWH (1/4"X14X1 1/2")	
9.	A21	3.454	PLATE, ACCEL PED LVR	10031636
10.	A21	3.451	PEDAL, ACCEL	14106884
11.		8.921	NUT, PUSH-ON (SELFLOCK EXT RET 1/4")	3909083
12.	A21	3.459	SPRING, ACCEL PED	10028507
13.	A21	3.431	LEVER, ACCEL PED	10029578
14.	A21	3.454	SUPPORT, ACCEL PED LVR	10031637

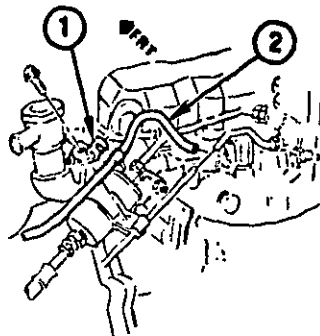

VACUUM SOURCE

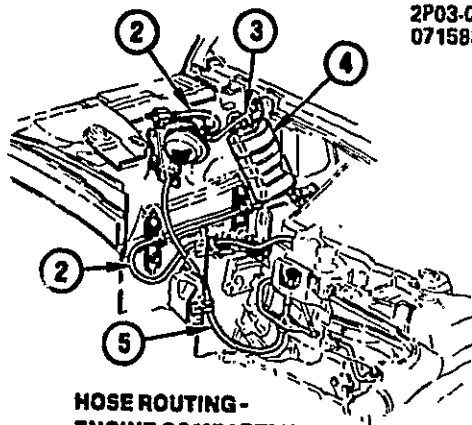

HOSE ROUTING-
ENGINE COMPARTMENT

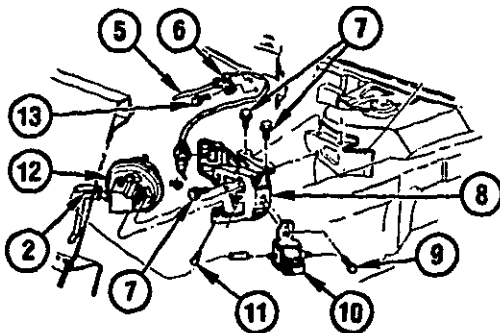

SERVO UNIT MTG.

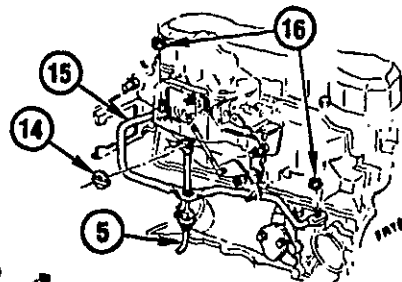

SERVO CABLE BRACKET

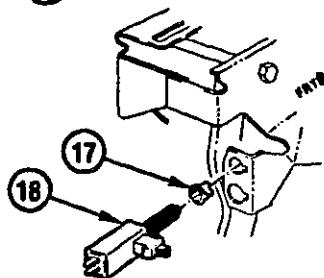

VACUUM RELEASE VALVE TO BRAKE PEDAL

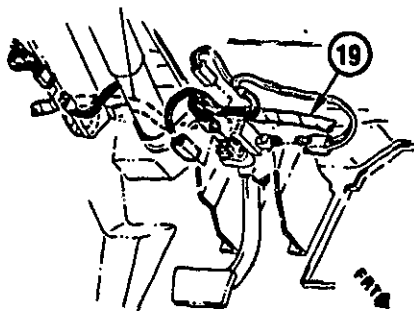

WIRING - PASSENGER COMPARTMENT.

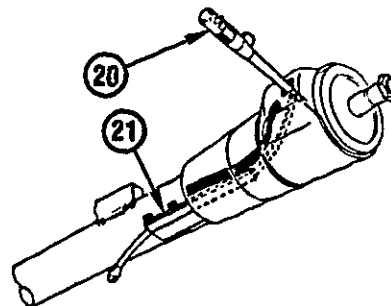

1984 P CRUISE CONTROL-L4 (LR8/2.5R)(K34)

1.	8.950	CLIP, PIPE (M10 5 X 18 X 19 W/TANG)		
2.	8.962	HOSE, VAC (3/8" X 24 FT)(#1)		
3.	8.962	HOSE, VAC (5/32" X 25 FT)(#1)		
4.	B9	3.886	TANK, CRUISE CONT VAC	10030178
5.	B8	3.880	CABLE, CRUISE CONT SERVO	10035893
6.		8.950	CLIP, CBL (1/4" X 17/32" X 1/2")	
7.		8.977	SCREW, HWH TAP (M6 3 X 1 81 X 16)	
8.	B8	3.885	BRACKET, CRUISE CONT SERVO	10029501
9.		8.977	SCREW, HWH TAP (M8 X 2 12 X 16)	
10.	B9	3.867	VALVE, CRUISE CONT SOL VAC	1997630
11.		8.977	SCREW, HWH (M4.2 X 1 41 X 13)	
12.	B8	3.885	SERVO, CRUISE CONT	25074809
13.		8.977	SCREW, HWH TAP (M6 3 X 1 81 X 13)	
14.	A20	3.425	RETAINER, 5/32" CABLE (8 821)	15567924
15.	B8	3.880	BRACKET, SERVO CBL	10034039
16.		8.917	NUT, HFH (M8 X 1 25)	
17.	N21	2.447	RETAINER, STOP LP SW	22534155
18.	N21	2.447	SWITCH, STOP LP W/CRUISE	25524645
19.	N21	2.480	HARNES, I/P	
20.	N22	2.897	LEVER, ACTR-W/PULSE (EXC PULSE WPR & CRUISE)	22510143
	N22	2.897	LEVER, ACTR-W/PULSE WPR (EXC CRUISE)	22510144
	N22	2.897	LEVER, ACTR-W/CRUISE (EXC PULSE WPR)	25111263
	N22	2.897	LEVER, ACTR-W/PULSE WPR & CRUISE	25111262
21.	B9	3.867	PROTECTOR, CRUISE CONT WIRE	7828271

NOTE 1 CUT TO REQUIRED LENGTH

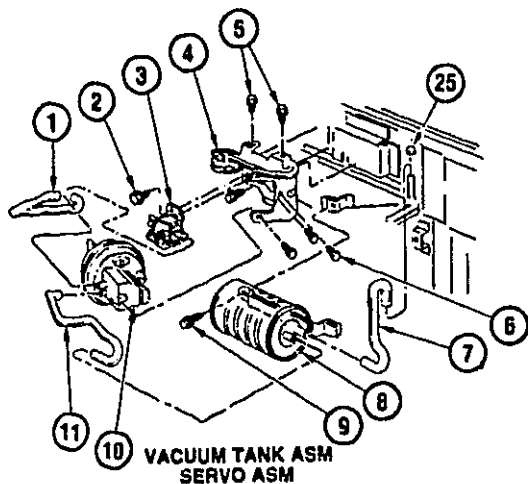

VACUUM TANK ASM
SERVO ASM

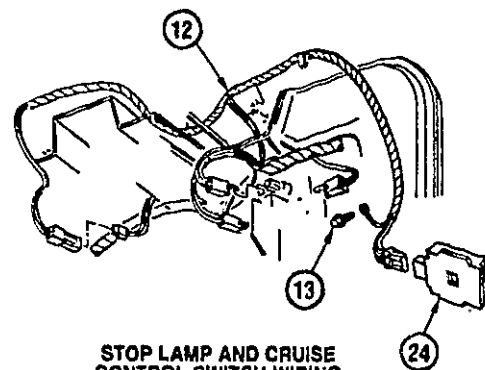

STOP LAMP AND CRUISE
CONTROL SWITCH WIRING

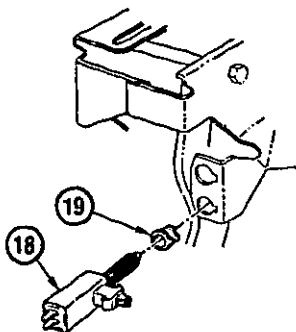

STOP LAMP AND
CRUISE CONTROL SWITCH

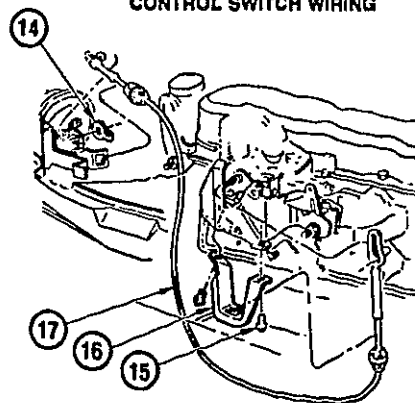

SERVO CABLE BRACKET

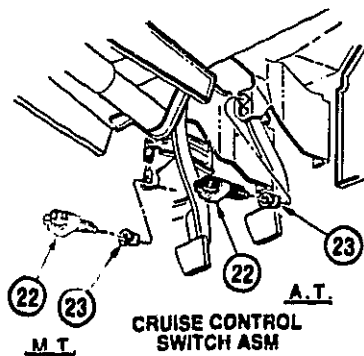

CRUISE CONTROL
SWITCH ASM

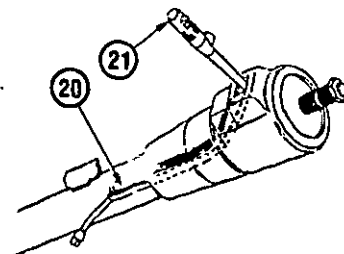

MULTI FUNCTION LEVER
AND SWITCH ASM

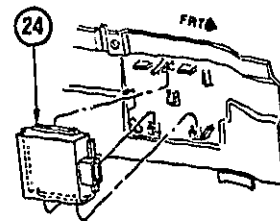

MODULE ASM TO
CARPET SUPPORT

1985 P CRUISE CONTROL-L4 (LR8/2.5R)(K34)

1.	N.S.	HOSE	
2.	8.977	SCREW, HWH TAP (M8X2 12X20)	
3	B9	3.887 VALVE, CRUISE CONT SERVO	
4.	B8	3.885 BRACKET, CRUISE CONT SERVO	10036747
5.	8.977	SCREW, HWH TAP (M6 3X1 81X13) PZOR	
6.	8.977	SCREW, HWH (M4 2X1 41X13)	
7.	N.S.	HOSE	
8.	B9	3.888 TANK, CRUISE CONT VAC	10035753
9.	8.977	SCREW, HWH TAP (M6 3X1 81X16)	
10.	B8	3.885 SERVO, CRUISE CONT	25074827
11.	N.S.	HOSE	
12.	B9	3.887 WIRE, CRUISE CONT	12046552
13.	8.977	SCREW, HWH (M4.7X1 59X13)	
14.	A20	3.425 RETAINER, 5/32" CABLE (8 821)	15567924
15.	8.900	BOLT, HFH (M8 X 1.25 X 18)(9 8 POR)	
16.	B8	3.880 BRACKET, CRUISE CONT SERVO CBL	10035863
17.	B8	3.880 CABLE, CRUISE CONT SERVO CBL	10038802
18.	N21	2.447 SWITCH, STOP LP W/CRUISE	25524845
19.	N21	2.447 RETAINER, STOP LP SW	22534155
20.	B9	3.887 PROTECTOR, CRUISE CONT WIRE	7828271
21.	N22	2.897 LEVER, ACTR-W/PULSE (EXC PULSE WPR & CRUISE)	22510143
	N22	2.897 LEVER, ACTR-W/PULSE WPR (EXC CRUISE)	22510144
	N22	2.897 LEVER, ACTR-W/CRUISE (EXC PULSE WPR)	25111263
	N22	2.897 LEVER, ACTR-W/PULSE WPR & CRUISE	25111262
22.	B8	3.883 SWITCH, CRUISE CONT VAC REL (BRK & CLU)	10024217
23.	B8	3.885 RETAINER, CRUISE CONT VAC REL VLV	1612303
24.	B9	3.887 MODULE, CRUISE CONT	25075044
25.	A11	3.278 CAP, VAC FITT (5/32" I.D X21/64 O.D. RUBBER)	489106

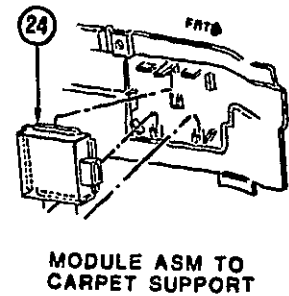
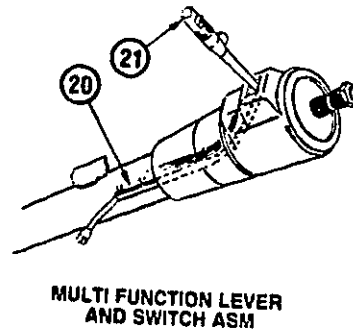
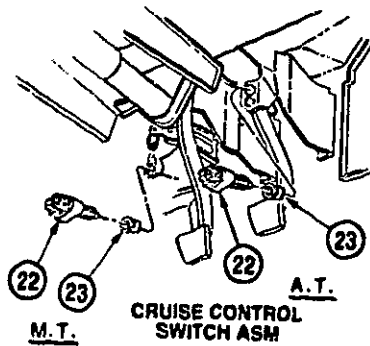
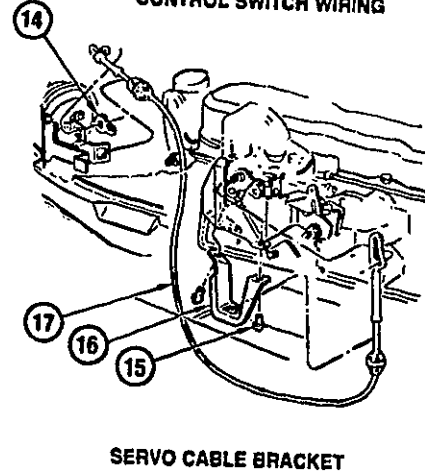
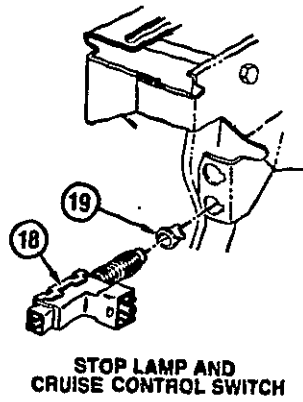
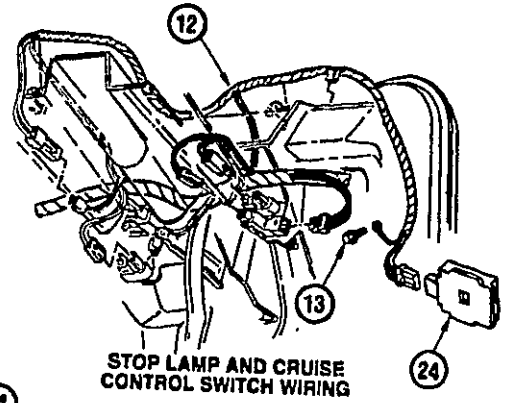
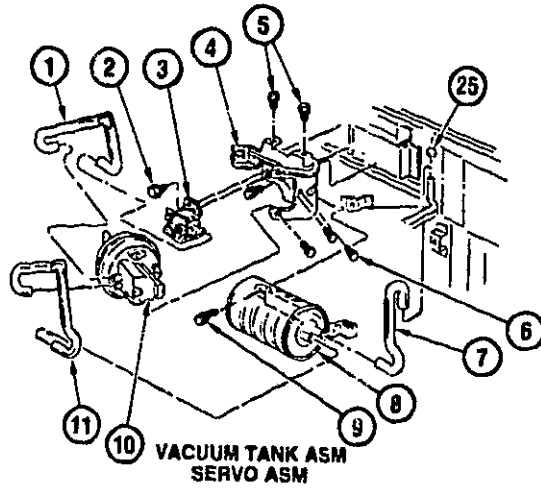

1986 P CRUISE CONTROL-L4 (LR8/2.5R)(K34)

1.	8.962	HOSE, VAC(* 1)	
	8.963	CONNECTOR, 90° ELBOW (3/16 HOSE) PLASTIC	9438381
2.	8.977	SCREW, HWH TAP (M8X2 12X20)	556992
3. B9	3.887	VALVE, CRUISE CONT SERVO	
4. B8	3.885	BRACKET, CRUISE CONT SERVO	
5.	8.977	SCREW, HWH TAP (M6 3X1 81X13) PZOR	10035747
6.	8.977	SCREW, HWH (M4 2X1 41X13)	
7.	N.S.	HOSE	
8. B9	3.886	TANK, CRUISE CONT VAC	10035753
9	8.977	SCREW, HWH TAP (M6 3X1 81X16)	
10. B8	3.885	SERVO, CRUISE CONT	25074627
11.	N.S.	HOSE	
12. B9	3.887	WIRE, CRUISE CONT	12046552
13.	8.977	SCREW, HWH (M4 7X1 59X13)	
14. A20	3.425	RETAINER, 5/32" CABLE (8 821)	15587924
15.	8.900	BOLT, HFH (M8 X 1 25 X 18)(9 8 POR)	
16. B8	3.880	BRACKET, CRUISE CONT SERVO CBL	10035883
17. B8	3.880	CABLE, CRUISE CONT SERVO CBL	10038802
18. N21	2.447	SWITCH, STOP LP W/CRUISE	25524846
19. N21	2.447	RETAINER, STOP LP SW	22534155
20. B9	3.887	PROTECTOR, CRUISE CONT WIRE	7828271
21. N22	2.897	LEVER, ACTR-W/PULSE (EXC PULSE WPR & CRUISE)	22510143
	N22	LEVER, ACTR-W/PULSE WPR (EXC CRUISE)	22510144
	N22	LEVER, ACTR-W/CRUISE (EXC PULSE WPR)	25111263
	N22	LEVER, ACTR-W/PULSE WPR & CRUISE	25111262
22. B8	3.883	SWITCH, CRUISE CONT VAC REL (BRK & CLU) ...	10024217
23. B8	3.885	RETAINER, CRUISE CONT VAC REL VLV	1612303
24. B9	3.887	MODULE, CRUISE CONT	25075044
25. A11	3.278	CAP. VAC FITT (5/32" I D X21/64 O D RUBBER)	489106

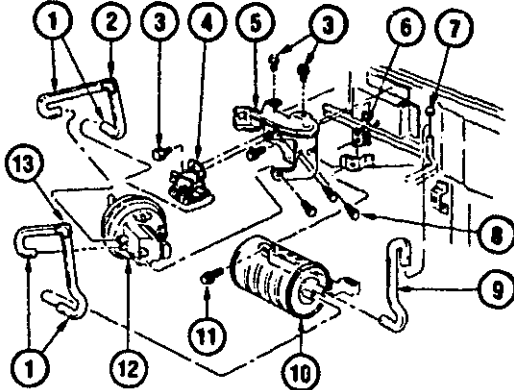

VACUUM TANK ASM
SERVO ASM

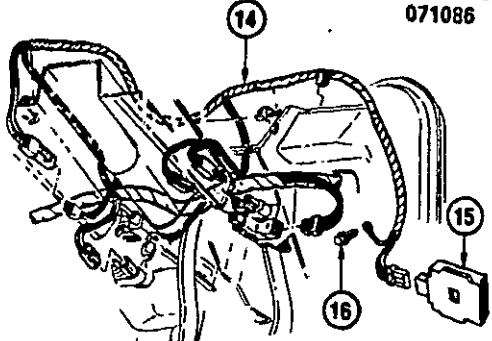

STOP LAMP AND CRUISE
CONTROL SWITCH WIRING

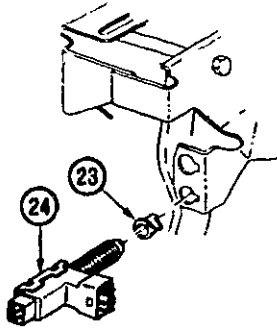

STOP LAMP AND
CRUISE CONTROL SWITCH

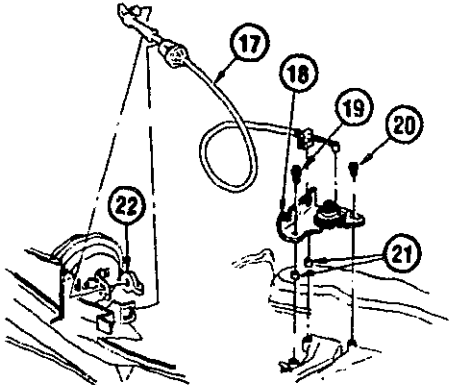

SERVO CABLE BRACKET

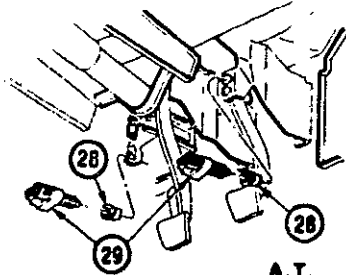

M.T. CRUISE CONTROL
SWITCH ASM
A.T.

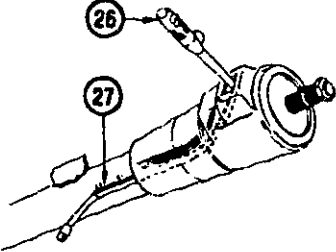

MULTI FUNCTION LEVER
AND SWITCH ASM

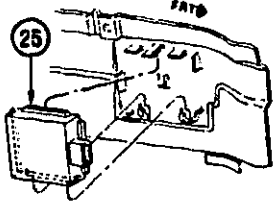

MODULE ASM TO
CARPET SUPPORT

1987-1988 P CRUISE CONTROL-L4 (LR8/2.5R)(K34)

1.		8.982	HOSE, VAC (5/32"X25"X1)	9438381
2.	B9	3.888	FITTING, CRUISE CONT VAC HOSE	10042286
3.		8.977	SCREW, HWH TAP (M6 3X1 81X13) PZOR	11508797
4.	B9	3.887	VALVE, CRUISE CONT SERVO	1997133
	N21	2.408	FILTER, VAC CONT VLV	801528
	B9	3.887	CLIP, CRUISE CONT VAC SOL VLV (3 671)	1986870
5.	B8	3.886	BRACKET, CRUISE CONT SERVO	10036747
6.		8.921	NUT, U SHAPE SPR (1/4-14)	9433043
7.	A11	3.278	CAP, VAC FITT (156 ID 320 OD) RUBBER	489108
8.		8.977	SCREW, HWH TAP (M8X2 12X20)	11509189
9.		N.S.	HOSE, VAC	
10.	B9	3.886	TANK, CRUISE CONT VAC	10036753
11.		8.977	BOLT, HWH TAP (M6 3X1 81X16) POR	12337828
12.	B8	3.886	SERVO, CRUISE CONT	25074627
13.		8.983	CONNECTOR, 90° ELBOW (3/16 HOSE PLASTIC)	656992
14.	B9	3.887	WIRE, CRUISE CONT JUMPER)	12069792
15.	B9	3.887	MODULE, CRUISE CONT (2 5R)	25075044
16.		8.977	SCREW, HWH (M4 2X1 41X13) ZP	22506732
17.	A20	3.430	CABLE, ACCEL & CRUISE CONT SERVO (2 5R W/MD9)	10046607
	A20	3.430	CABLE, ACCEL & CRUISE CONT SERVO (2 5R W/MT2)	10046609
18.		N.S.	BRACKET, CRUISE CONT-W/PULLEY	
	A21	3.454	PULLEY, THROT IDL (2 5R W/MD9)	10041788
19.		8.900	BOLT, HFH (M8X1 25X35) 10 9 PZOR	11507034
20.		8.900	BOLT, HFH (M8X1 25X20) 10 9 POR	11514343
21.	A21	3.454	SPACER, BRKT	10044708
22.	B8	3.880	RETAINER, 5/32" CABLE (8 821)	15567924
23.	N21	2.447	RETAINER, STOP LP SW	22534155
24.	N21	2.447	SWITCH, STOP LP	25529880
25.	B9	3.887	MODULE, CRUISE CONT	25075044
26.	N22	2.897	LEVER, W/ACTR.T/SIG.WSW.WSWA AND D/SW	25111263
27.	B9	3.887	PROTECTOR, CRUISE CONT WIRE	7828271
28.	B8	3.886	RETAINER, CRUISE CONT VAC REL VLV	1812303
29.	B8	3.883	SWITCH, CRUISE CONT & TORQ CONV VAC REL	10024217

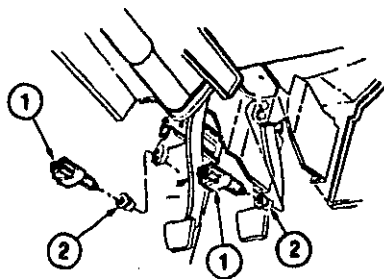

M.T. A.T.
CRUISE CONTROL SWITCH ASM.

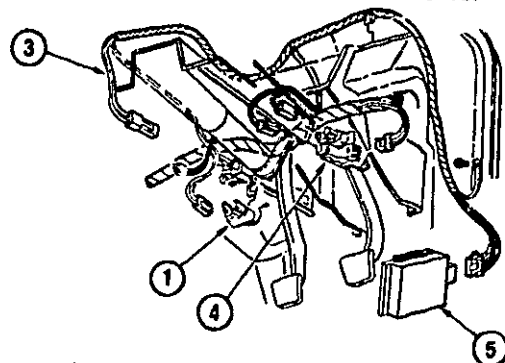

**STOPLAMP, CRUISE CONT. &
NEUTRAL START SWITCH WRNG**

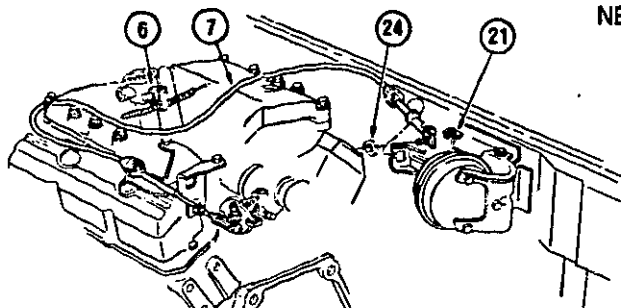

CABLE ASM-CRUISE CONTROL

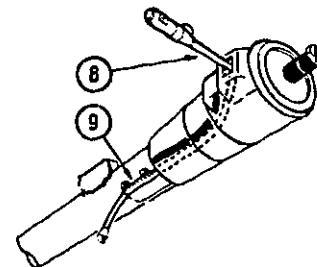

**MULTI FUNCTION LEVER
AND SWITCH ASM.**

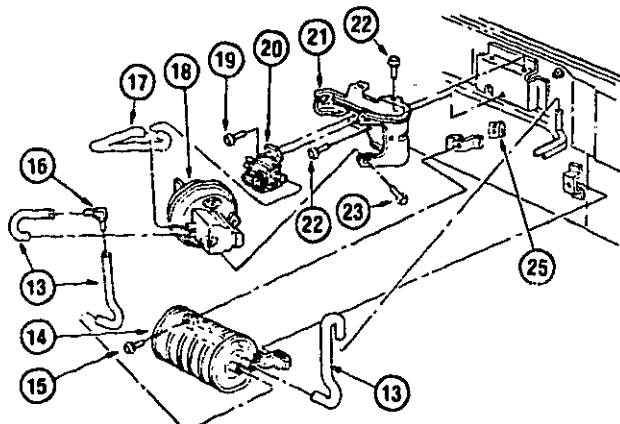

**VACUUM TANK ASM.
SERVO ASM.**

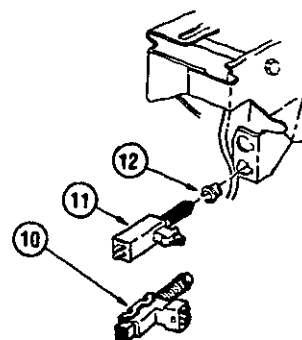

**STOP LAMP AND
CRUISE CONTROL SWITCH**

1985-1988 P CRUISE CONTROL-V6 (L44/2.8-9)(K34)

1.	B8	3.883	SWITCH, BRK & CLU VAC REL	10024217
2.	B8	3.885	RETAINER, VAC REL VLV	10075405
3.	B9	3.887	WIRE, JUMPER (1985)(1)	12046552
	B9	3.887	WIRE, JUMPER (1986)	12046552
	B9	3.887	WIRE, JUMPER (1987-88)	12089792
4.	N21	2.447	SWITCH, STOP LP	25529860
5.	B9	3.887	MODULE, CRUISE CONT	25110878
6.	B8	3.885	CLIP, CRUISE CONT SERVO CBL/TO THERM HSG	10035494
7.	B8	3.880	CABLE, CRUISE CONT SERVO	10042227
8.	N22	2.897	LEVER, T/SIG-WSW-WSWA-D/SW (EXC PULSE WPR)	25111263
	N22	2.897	LEVER, T/SIG-WSW-WSWA-D/SW (W/PULSE WPR)	25111262
9.	N22	2.908	PROTECTOR, STRG COL WIRING	7836530
10.	N21	2.447	SWITCH, STOP LP	25529860
11.	N21	2.447	SWITCH, STOP LP (1985)	25529860
12.	N21	2.447	RETAINER, STOP LP SW	22534155
13.		8.982	HOSE, VAC (5/32"X25")(1)	
		8.983	CONNECTOR, 90° ELBOW (3/16")	
14.	B9	3.886	TANK, CRUISE CONT VAC	10035753
15.		8.977	BOLT, HWH TAP (M6 3X1 81X16)	
16.		8.983	CONNECTOR, 90° ELBOW (3/16 HOSE PLASTIC)	556992
17.		N.S.	HOSE, SERVO TO VALVE	
18.	B8	3.885	SERVO, CRUISE CONT	25074627
19.		8.977	SCREW, HWH TAP (M8X2 12X20) POR	11509189
20.	B9	3.887	VALVE, CRUISE CONT SERVO	1997133
	N21	2.408	FILTER, VAC CONT VLV	801528
	B9	3.887	CLIP, CRUISE CONT VAC SOL VLV (3 671)	1985870
21.	B8	3.885	BRACKET, CRUISE CONT SERVO	10035747
22.		8.977	SCREW, HWH TAP (M6 3X1 81X13) PZOR	
23.		8.977	SCREW, HWH (M4 2X1 41X13) POR	11508256
24.	A20	3.425	RETAINER, 5/32" CABLE (8 821)	15587924
25.		8.921	NUT, TYPE P-WU SPR (M6 3X1 81)PHOS ORG	11514290

NOTE 1 WHEN USED ON AUTOMATIC TRANSMISSIONS, SPLICE CLUTCH WIRES TOGETHER

2P03-004
083088

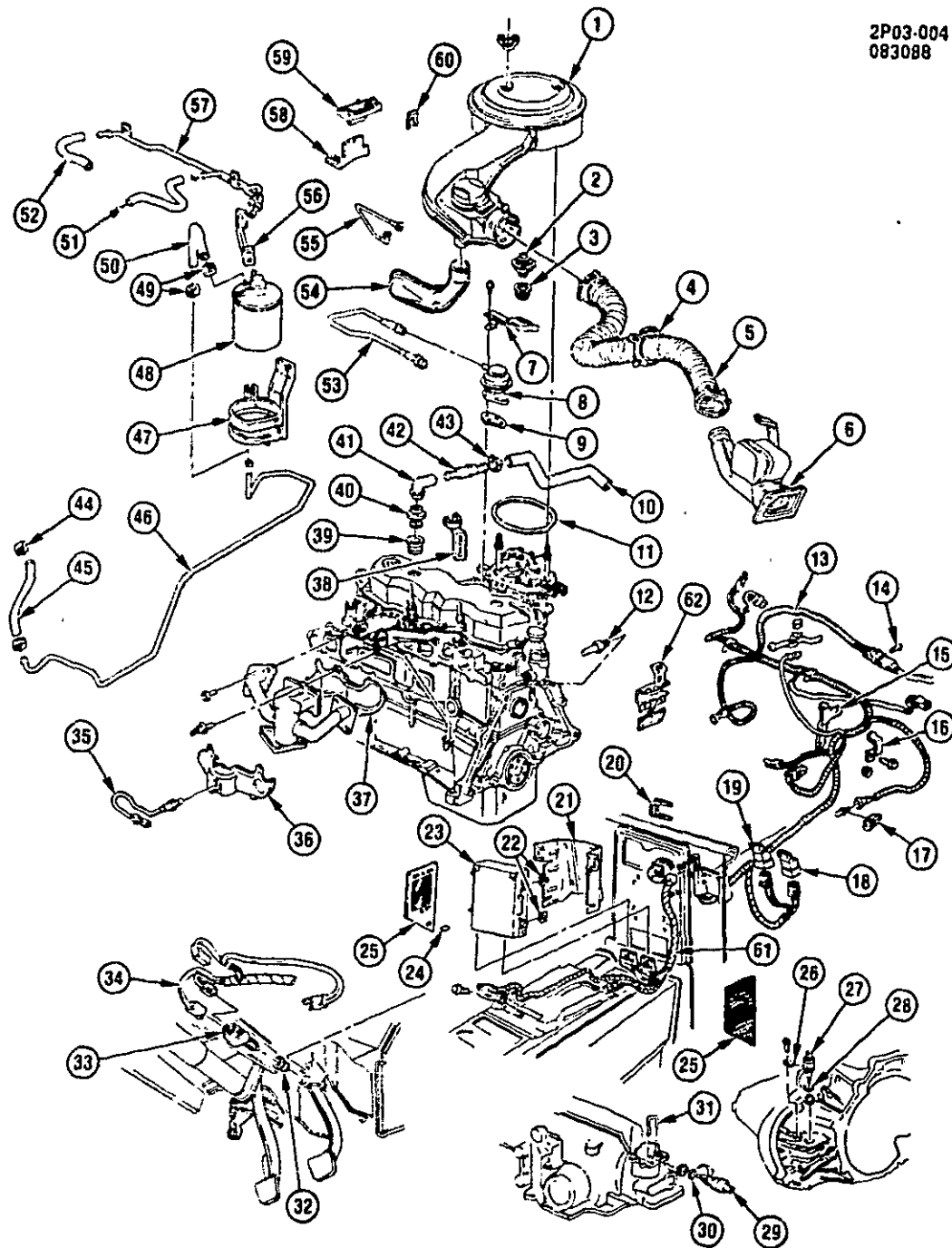

2P03-004

1984 P EMISSION CONTROLS-L4 (LR8/2.5R)

1.	A17	3.402	AIR CLEANER, TBI	25043307
	A20	3.415	MOTOR, A/CL DIAPH	25041109
	A20	3.415	SENSOR, AIR CLEANER	8997574
2.	N19	1.745	SEPARATOR KIT, CR/CASE VENT OIL	25041743
3.	N19	1.745	GROMMET, C/CASE VENT TO RKR ARM CVR	10037288
4.		8.965	STRAP (14 5 LONG-FINE TEETH)	
5.	A20	3.417	DUCT, AIR INT RR	10030243
6.	A20	3.417	DUCT, AIR INT FRT	10030240
	A20	3.417	ADAPTER, AIR INTAKE-W/WATER SEPARATOR	10030241
		8.948	CLAMP, WORM (2 1/2".3 1/2")	
	A20	3.417	BRACKET, AIR INT DUCT LWR	10030452
	A20	3.417	BRACKET, AIR INT DUCT UPR	10030451
7.	A23	3.671	SHIELD, EGR VLV TO TPS	17111750
8.	A22	3.670	VALVE, EGR	17110478
9.	A24	3.680	GASKET, EGR VLV TO PLENUM	10009588
10.	N19	1.762	HOSE, C/CASE VENT (3/8")	
11.	A20	3.403	SEAL, AIR CLEANER	10019632
12.	A24	3.682	SENSOR, COOLANT TEMP	25036092
13.	N21	2.480	HARNES, CONT MDL	12027633
14.		N.S.	RETAINER, HARNES	
15.	N22	2.559	BRACKET, HARNES TO BELL HSG	10023838
16.		N.S.	RETAINER, HARN BRKT (USE STRAP-8 965)	
17.		N.S.	RETAINER, HARNES	
18.	N26	9.277	RELAY, A C CONT	10034222
	N26	9.277	BRACKET, CONT RELAY (3 900)	10022615
	N28	9.277	LATCH, CONT RELAY (3 900)	10023153
19.	B9	3.900	RELAY, FUEL PUMP (9 277)	10034222
	B9	3.900	BRACKET, PUMP RELAY	10022615
	B9	3.900	LATCH, PUMP RELAY	10023153
20.	A23	3.671	RETAINER, CONT MDL WRG	12020307
21.	A23	3.671	BRACKET, CONT MDL TO RR BLKHD	10021279
22.	A23	3.671	BOLT, U NUT & STUD (M5X 8X10) 9 667)	12337892
23.	A22	3.670	CONTROLLER, ECM	1228156
	A22	3.670	CALIBRATOR, PROM(*1)	
24.	A23	3.671	CLIP, MDL VENT GRL (10 252)	25510099
25.	N26	10.240	GRILLE, CONT MDL VENT-RH (PAINT)	10039985
	N26	10.240	GRILLE, CONT MDL VENT-LH	10039986
26.	C11	4.338	RETAINER, SPD SEN (M T)	3708148
27.	A24	3.682	SENSOR, VEH SPD (M T)	25007316
28.	C11	4.338	SEAL, SPD SEN (M T)	464885
29.	A24	3.682	SENSOR, VEH SPD (A T)	25007268
30.	C11	4.338	SEAL, O-RING, SPD SEN (A T)	8822076
31.	C11	4.338	RETAINER, SPD SEN (A T)	25513329
32.	B8	3.685	RETAINER, VAC REL VLV	1612303
33.	B8	3.683	SWITCH, CRUISE CONT VAC REL (BRK & CLU)	10024217
34.	N21	2.480	HARNES, INST PNL(*1)	
35.	A24	3.682	SENSOR, EXH OXYGEN	8990741
36.	A20	3.417	STOVE, ENG AIR HT OTR	
37.	A20	3.417	STOVE, ENG AIR HT INR	10184939
38.	N19	1.762	BRACKET, C/CASE VENT VLV HOSE	10028643
39.	N19	1.745	GROMMET, C/CASE VENT VLV TO RKR ARM CVR	10037288
40.	N19	1.745	CONNECTOR, C/CASE VENT VLV ELBOW	10030429
41.	N19	1.762	ELBOW, C/CASE VENT VLV	10037288
42.	N19	1.745	VALVE, C/CASE VENT (CV-864C)	25041498
43.		N.S.	CLAMP, HOSE	
44.		8.948	CLAMP, WORM (25". 63")	
45.		8.962	HOSE, VAPOR (1/4")	
46.		8.964	TUBING, VAPOR (1/4")	
47.	A9	3.130	SUPPORT, VPR CNSTR	10031888
48.	A9	3.130	CANISTER, FUEL VAPOR	17075840
49.		8.948	CLAMP, HOSE (562)	
50.		8.962	HOSE, VAPOR (5/16")	
51.		8.982	HOSE, PIPE TO FTG (5/32")	
52.		8.962	HOSE, PIPE TO TBI (7/32")	
53.		8.962	HOSE, EGR CONT (5/32")	
54.	A20	3.417	TUBE, ENG AIR HT STOVE	10045291
55.		8.962	HOSE, PRESS SEN (5/32")	
56.	A10	3.163	HOSE, VPR CNSTR PURGE	10029200
57.	A10	3.163	PIPE, VPR CNSTR PURGE	10031713
58.	A24	3.682	BRACKET, M A P SENSOR	10026710
59.	A24	3.682	SENSOR, M A P	16017460
60.	N19	1.745	RETAINER, "U" SHAPE (1 64 X 1 25)	22630004
61.	N21	2.480	HARNES, I/P WRG	12043162

62. N22 2.559 SHIELD, ENG WRG HARN & EFI WRG AT FRT CVR
290. 4.329 SENSOR,VEH SPD(TRANS MTD)

10041855
25007268

NOTE 1 SEE CHART IN GROUP FOR USAGE

2P03-008
092586

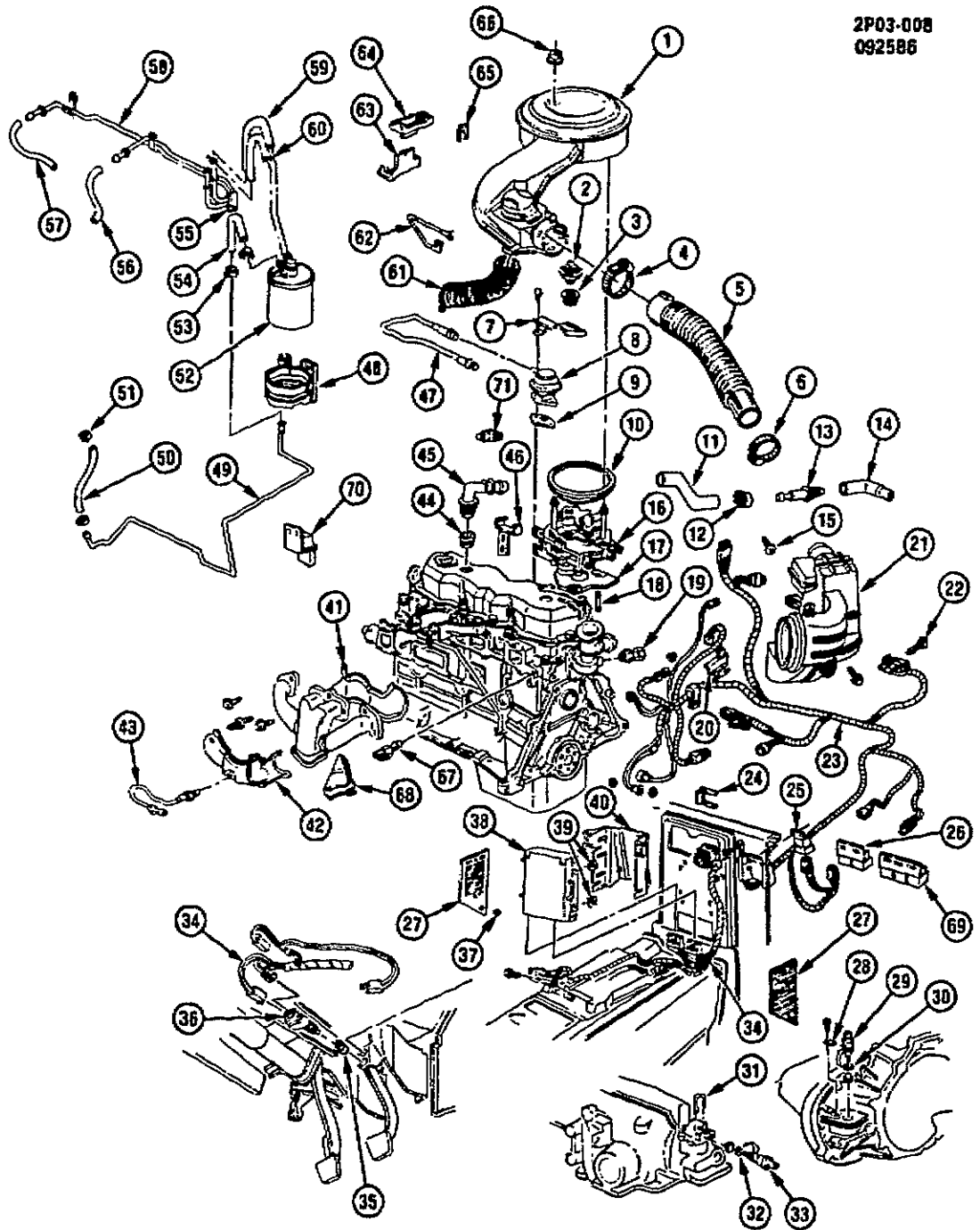

2P03-008

1985-1986 P EMISSION CONTROLS-L4 (LR8/2.5R)

1.	A17	3.402	AIR CLEANER, TBI (1985)	25043905
	A17	3.402	AIR CLEANER, TBI (1986)(CPS)	
	A20	3.415	MOTOR, A/CL DIAPH	25042077
	A20	3.415	SENSOR, A/CL	8997787
2.	N19	1.745	SEPARATOR KIT, CR/CASE VENT OIL	25041743
3.	N19	1.745	GROMMET, C/CASE VENT TO RKR ARM CVR	10037287
4.		8.948	CLAMP, WORM (52 4-74MM SS.W/LINER)	10041052
5.	A20	3.417	DUCT, A/CL TO AIR INT DUCT	10034320
6.	A20	3.417	CLAMP, AIR INT DUCT RR	14086928
7.	A23	3.671	SHIELD, EGR VLV TO TPS	17111750
8.	A22	3.670	VALVE, EGR	17110478
9.	A24	3.680	GASKET, EGR VLV TO PLENUM	10009586
10.	A20	3.403	SEAL, A/CL	10019632
11.	N19	1.762	HOSE, C/CASE VENT VLV TO ELBOW	10032420
12.		8.948	CLAMP, WORM GEAR (80-1 25. ZOR) SS W/LINER (1 174)	
13.	N19	1.745	VALVE, CR/CASE VENT (CV881C)	25043669
14.	N19	1.762	BOOT, C/CASE VENT VLV	10036943
15.	N28	12.815	NUT, DUCT TO PANEL	
16.	A27	3.725	THROTTLE, BODY INJ(*3)	
17.	B8	3.726	INSULATOR, TBI TO INT MANIF (1985)	10140578
	B8	3.726	INSULATOR, TBI TO INT MANIF (1986)	10140591
18.	A11	3.288	STUD, TBI TO INT MANIF (53 0 LG)	25609575
19.	A24	3.682	SENSOR, CLNT TEMP (1 150)	25036979
20.	N22	2.559	SHIELD, WRG HARN (ENG & EFI WRG AT FRT CVR-W/A C)	10041855
21.		N.S.	DUCT ASM, AIR INT FRT/SERV BY.	
	A20	3.417	DUCT, AIR INT WATER SEP	10044264
	A20	3.417	DUCT, AIR INT FRT (TO ADAPTER)	10030240
	A20	3.417	BRACKET, AIR INT DUCT LWR	10030452
	A20	3.417	BRACKET, AIR INT DUCT UP	10030451
22.		N.S.	RETAINER, WRG HARN (NYLON)	
23.	N22	2.525	HARNESS, ENG (1985)	12049878
	N22	2.525	HARNESS, ENG (1986)	12051893
24.	A23	3.671	RETAINER, CONT MDL WRG HARN GROM	12020307
25.	B9	3.900	RELAY, FUEL PUMP (9 277)	10034222
	B9	3.900	BRACKET, FUEL PUMP RLY	10022815
	B9	3.900	LATCH, FUEL PUMP RLY	10023153
26.	N26	9.277	RELAY, A/C CONT	10034222
	N26	9.277	BRACKET, A/C CONT RLY (3 900)	10022815
	N26	9.277	LATCH, A/C CONT RLY (3 900)	10023153
27.	N26	10.240	GRILLE, CONT MDL VENT-RH(* 1)	10039986
	N26	10.240	GRILLE, CONT MDL VENT-LH(* 1)	10039986
28.	C11	4.338	RETAINER, SPD SEN (M T)	3708148
29.	A24	3.682	SENSOR, VEH SPD (M T)(TRANS MTD)	25007714
30.	C11	4.338	SEAL, SPD SEN (M T)	484865
31.	C11	4.338	RETAINER, SPD SEN (A T)	25513329
32.	C11	4.338	SEAL, SPD SEN (A T)	8622076
33.	A24	3.682	SENSOR, VEH SPD (A T)(TRANS MTD)	25007268
34.	N21	2.480	HARNESS, I/P(*3)	
35.	B8	3.885	RETAINER, VAC REL VLV	1612303
36.	B8	3.883	SWITCH, CRUISE CONT VAC REL (BRK & CLU)	10024217
37.	A23	3.671	CLIP, MDL VENT GRL (10 252)	25510099
38.	A22	3.670	CONTROLLER, ECM	1226864
	A22	3.670	CALIBRATOR, PROM(*3)	
39.	A23	3.671	BOLT, U NUT & STUD (M5X 8X10)(9 667)	12337892
40.	A23	3.671	BRACKET, CONT MDL TO RR BLKHD	10021279
41.	A20	3.417	STOVE, ENG AIR HT INR	10032879
42.	A20	3.417	STOVE, ENG AIR HT OTR	10184939
43.	A24	3.682	SENSOR, EXH OXYGEN	8990741
44.	N19	1.745	GROMMET, C/CASE VENT HOSE	10037288
45.	N19	1.762	ELBOW, C/CASE VENT VLV (GROM TO HOSE)	10036911
46.	N19	1.745	BRACKET, C/CASE VENT VLV HOSE GDE	10032421
47.		8.962	HOSE, EGR VLV TO TBI (5/32"X25')	
48.	A9	3.130	SUPPORT, VPR CNSTR	10039220
49.		8.984	TUBING, FUEL VPR (1/4"X25')	
50.		8.962	HOSE, VPR (5/16"X24')	
51.		8.948	CLAMP, WORM GEAR HEX SLOT SCREW (250 X 625) SS	
52.	A9	3.130	CANISTER, FUEL VAPOR	17075840
53.		8.948	CLAMP, HOSE (SPRING BAND)(562)	
54.		8.962	HOSE, VPR PIPE TO CNSTR (5/16"X24')	9438315
55.	A9	3.162	CLIP, VPR PIPE TO CNSTR PURGE (POS.#3)(4 686)	343438
56.		8.962	HOSE, PURGE PIPE TO VAC FTG (5/32"X25')	9438381
57.		8.962	HOSE, PURGE PIPE TO TBI (7/32"X25')	9439274
58.	A9	3.120	PIPE, VPR CNSTR PURGE (CNSTR TO TBI)(1985)	10042050

58.	A9	3.120	PIPE, VPR CNSTR PURGE (CNSTR TO TBI)(1986)	10042050
59.		8.962	HOSE, PURGE PIPE TO CNSTR (5/32"X25')	9438351
60.		8.962	HOSE, PURGE PIPE TO CNSTR (7/32"X25')	9439274
61.	A20	3.417	TUBE, ENG AIR HT STOVE	10045291
62.		8.962	HOSE, SENSOR TO TBI (5/32"X25')	9438351
63.	A24	3.682	BRACKET, M A P SENSOR	10026710
64.	A24	3.682	SENSOR, M A P	16017460
65.	N19	1.745	RETAINER, "U" SHAPED (1 64 X 1 25)	22530004
66.	A20	3.403	NUT, A/CL	10031019
67.	N17	1.055	SWITCH, ENG COOL TEMP FAN CONT	3050223
68.	N18	1.060	SHIELD, ENG COOL TEMP FAN CONT SW	10032484
69.	N26	9.277	RELAY, A/C CMPR	10034222
	N26	9.277	BRACKET, A/C CONT RLY (3 900)	10029398
70.	N17	1.055	RELAY, ENG COOL FAN W/A C (EXC H D C)	10038311
	N17	1.055	RELAY, ENG COOL FAN (2 STAGE FAN) W/H D C .A C	10040131
71.	N19	1.800	SENSOR, F/PMP SW & ENG OIL PRESS	10045775

NOTE 1 PAINT TO MATCH

NOTE 3 SEE CHART IN GROUP FOR USAGE

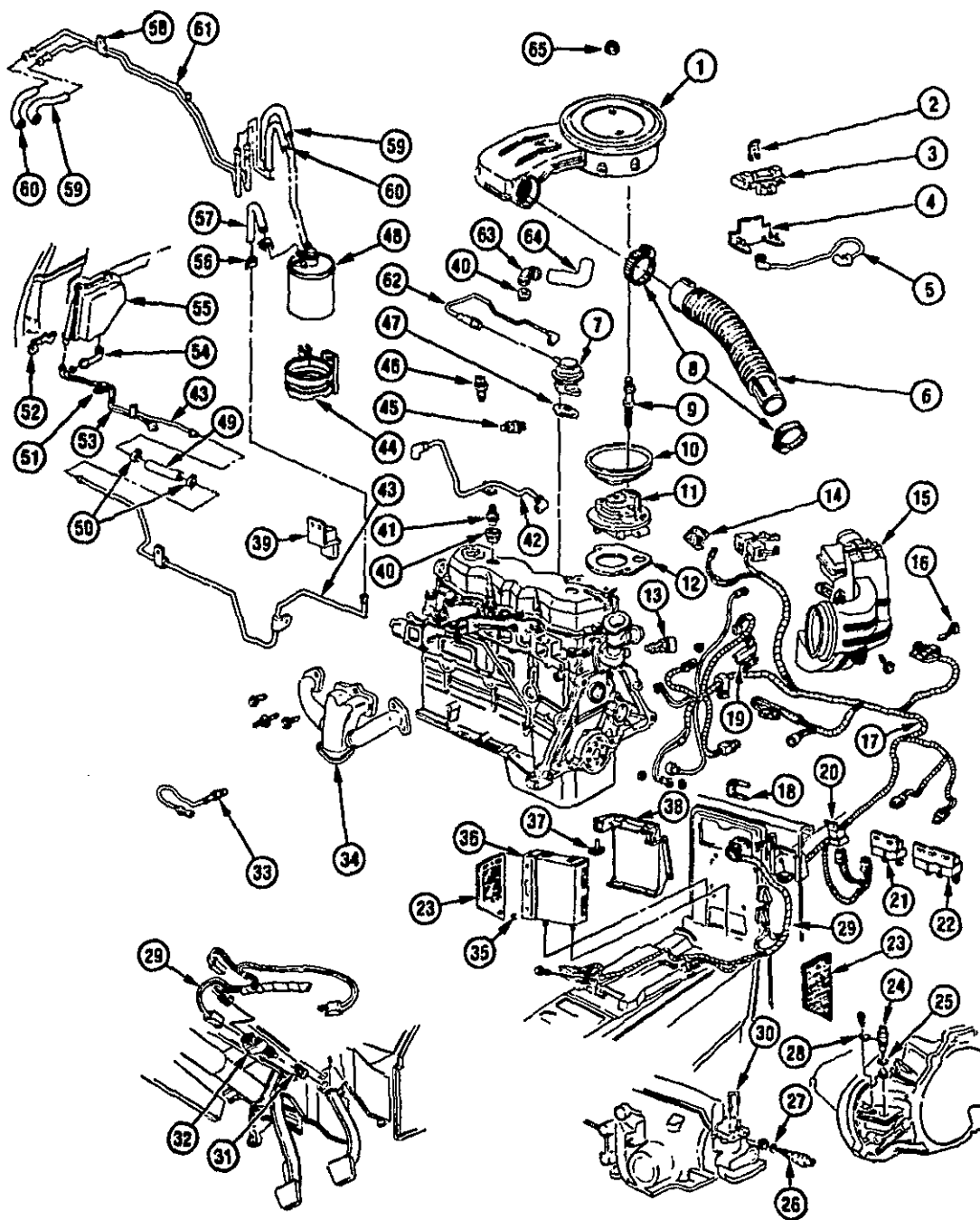

1987-1988 P EMISSION CONTROLS-L4 (LR8/2.5R)

1	A17	3.402	AIR CLEANER, TBI	25098335
	A20	3.410	ELEMENT (POLYWRAP)A913C)	25043317
2	N19	1.745	RETAINER, U SHAPED (1 64X1 25) STL	22530004
3	A20	3.410	BREATHER, A/CLNR	25041457
4	A24	3.682	BRACKET, M A P SEN	10026710
5	A24	3.675	TUBE, M A P SEN VAC	10043092
6	A20	3.417	DUCT, AIR INT RR	10044285
7	A22	3.670	VALVE, EGR	17110478
8	A20	3.417	CLAMP, AIR INT DUCT RR	14088928
9	A11	3.268	STUD, TBI (M8X1 25.M8X1 25X64) 9 8 POR	10044417
10	A20	3.403	GASKET, A/CLNR	10042945
11	A27	3.725	THROTTLE, BODY INJ(*1.2)	
12	B8	3.728	GASKET, TBI	10086805
13	A24	3.682	SENSOR, CLNT TEMP (1 150)	25036979
14	N21	2.342	BLOCK, ENG WRG HARN JUNC	3898270
15	A20	3.417	DUCT, FRT AIR INT WAT SEP	10044264
	A20	3.417	DUCT, FRT AIR INT TO QTR PNL	10030240
	A20	3.417	BRACKET, FRT AIR INT DUCT LWR	10030452
	A20	3.417	BRACKET, FRT AIR INT DUCT UPR	10030451
16		N.S.	RETAINER, WRG HARN (NY)	
17	N22	2.526	HARNES, ENG	12076768
18	N22	2.559	RETAINER, BODY WRG HARN GROM (3 671)	12020307
19	N22	2.559	SHIELD, ENG WRG HARN AT FRT CVR W/A C	10041855
20	B9	3.900	RELAY, F/PUMP (9 27 /)	10034222
	B9	3.900	BRACKET, F/PUMP RLY	10022615
	B9	3.900	LATCH, F/PUMP RLY	10023153
21	N26	9.277	RELAY, A C CMPR	10034222
	N26	9.277	BRACKET, A C CMPR RLY (3 900)	10029398
	N26	9.277	LATCH, A C CMPR RLY (3 900)	10023153
22	N26	9.277	RELAY, A C CMPR	10034222
	N26	9.277	BRACKET, A C CMPR RLY (3 900)	10029398
	N26	9.277	LATCH, A C CMPR RLY(3 900)	10023153
23	N26	10.240	GRILLE, ELEK FUEL CONT MDL VENT-RH	10039986
	N26	10.240	GRILLE, CONT MDL VENT-LH	10039986
24	A24	3.682	SENSOR, VEH SPD (W/M T)	25007714
25	C11	4.338	SEAL, VEH SPD SEN	4648865
26	A24	3.682	SENSOR, VEH SPD (TRANS MTD)W/A T)	25007268
27	C11	4.338	SEAL, O RING VEH SPD SEN	8622078
28	C11	4.338	RETAINER, VEH SPD SEN	3708148
29	N21	2.480	HARNES, I/P WRG(*2)	
30	C11	4.338	RETAINER, VEH SPD SEN	25513329
31	B8	3.885	RETAINER, CR/CONT VAC REL VLV	10075405
32	B8	3.883	SWITCH, CR/CONT & TORQ CONV VAC REL (A T)	10024217
33	A24	3.682	SENSOR, EXH OXYGEN (1 WIRE(1987)	8990741
	A24	3.682	SENSOR, EXH OXYGEN (1988)	25105107
34	A21	3.601	MANIFOLD, EXH (1987)	10044374
	A21	3.601	MANIFOLD, EXH (1988)	10088873
35	A23	3.671	CLIP, ELEK FUEL CONT MDL VENT GRL (10 252)	25510099
36	A22	3.670	CONTROLLER, ECM	1227748
37	A23	3.671	BOLT, U NUT & STUD (M5X 8X10)9 667)	12337892
38	A23	3.671	BRACKET, ELEK FUEL CONT MDL TO RR BHD	10042616
39	N17	1.055	RELAY, ENG COOL FAN (1987)	10038311
	N17	1.055	RELAY, ENG COOL FAN (1988)	14089936
40	N19	1.745	GROMMET, RKR ARM CVR	10037287
41	N19	1.745	VALVE, CR/CASE VENT (CV895C)	25095452
42		N.S.	TUBE, CR/CASE VENT VLV	
43		8.964	TUBING, STL (1/4)	
44	A9	3.130	SUPPORT, FUEL VPR CNSTR	10039220
45	N19	1.800	SENSOR, F/PUMP SW & ENG OIL PRESS (1987)	10045775
	N19	1.800	SENSOR, F/PUMP SW & ENG OIL PRESS (1988)	10098169
46	A24	3.682	SENSOR, MANIF AIR TEMP (1987)	25038751
	A24	3.682	SENSOR, MANIF AIR TEMP (1988)	25037225
47	A24	3.680	GASKET, EGR VLV TO PLNM	10009586
48	A9	3.130	CANISTER, FUEL VPR	17075840
	A9	3.130	FILTER, CNSTR	7021743
49		8.962	HOSE, FUEL OIL EVAP (1/4X24)	
50		8.948	CLAMP, WORM GEAR HEX SLOT SCREW (250 X 625) SS	25518880
51	A9	3.162	CLIP, FUEL VPR PIPE	14020587
52	A9	3.118	BRACKET, FUEL VPR TK	10041450
53		8.964	TUBING (5/16X25)	1324714
54	A9	3.145	HOSE, F/VPR TK RR	10041463
55	A9	3.118	TANK, F/VPR	10041455
58		8.948	CLAMP, SPRG BAND (14 2MM.9/16 OD HOSE)	25526358

57.		8.982	HOSE, F/OIL EVAP (5/16X24)	9438315
58.	A9	3.182	CLIP, F/VPR PIPE TO CNSTR PURGE (4 686)	343438
59.		8.982	HOSE, F/OIL EVAP (5/32X25)	9438381
60.		8.982	HOSE, F/OIL (7/32X25)	9439274
61.	A9	3.145	PIPE, F/VPR CNSTR PURGE	10044288
62.	A24	3.675	TUBE, EGR VLV VAC	10044339
63.	N19	1.762	FITTING, CR/CASE VENT	10021028
64.	N19	1.762	HOSE, CR/CASE VENT	10043081
65.		8.917	NUT, HFH (MBX1 25X7 5) 10 PEOR	11507038

NOTE 1 SEE RESPECTIVE GROUP FOR DETAILED ILLUSTRATED VIEW
NOTE 2 SEE CHART IN GROUP FOR USAGE

2P03-013
082389

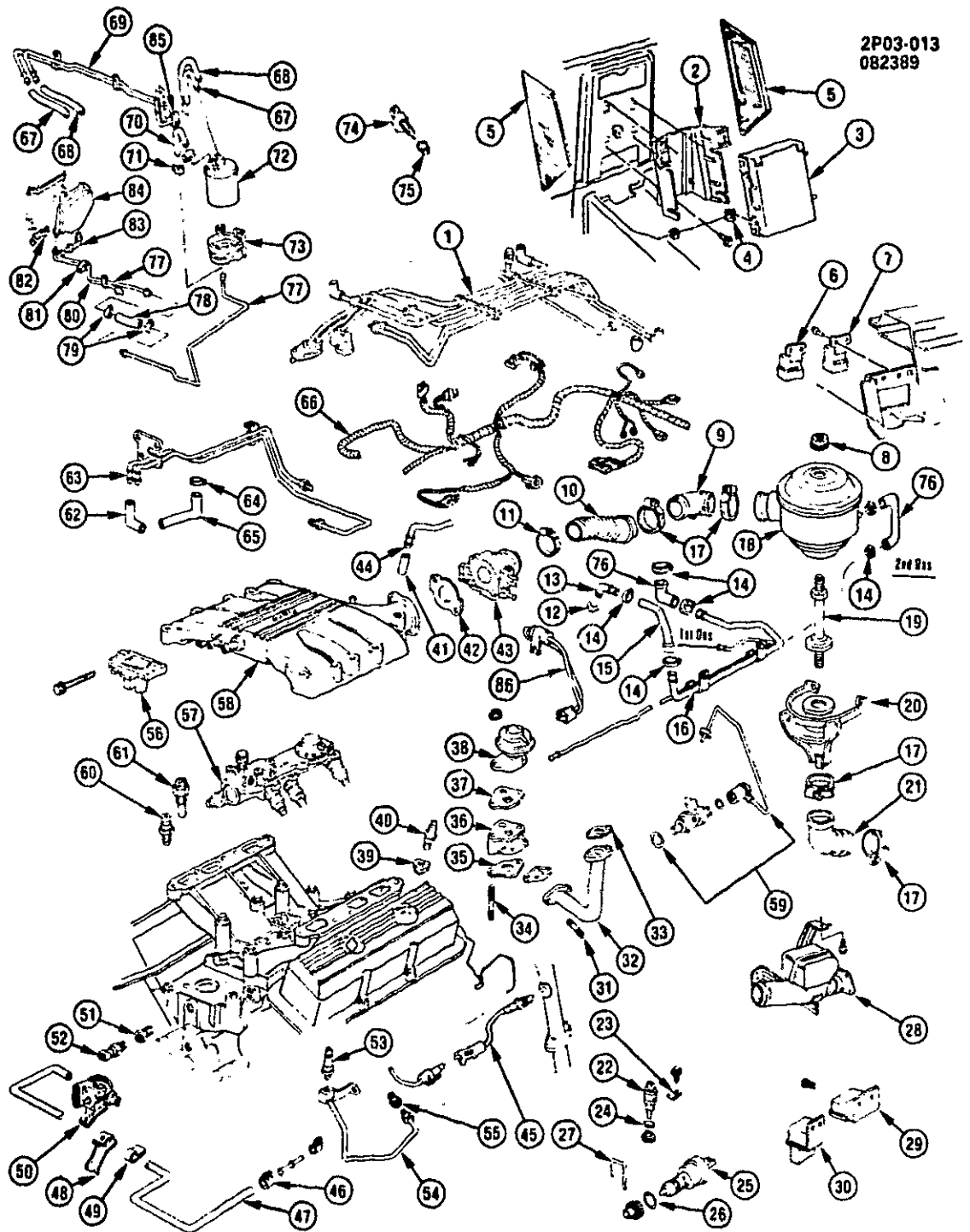

2P03-013

1985-1988 P EMISSION CONTROLS-V6 (L44/2.8-9)

1.	A24	3.875	HARNASS, EGR VLV VAC	10040419
2.	A23	3.671	BRACKET, CONT MDL TO RR BLKMD	10021279
3.	A22	3.670	CONTROLLER, ECM (1985)	1228889
	A22	3.670	CONTROLLER, ECM (1986-88)	1227170
	A22	3.670	CALIBRATOR, PROM	
	A22	3.670	CALPAK, ECM	16044801
4.	N26	9.667	BOLT, U NUT & STUD (M5x dX10)(3 671)	12337892
5.	N26	10.240	GRILLE, CONT MDL VENT-RH	10039985
	N26	10.240	GRILLE, CONT MDL VENT-LH	10039986
6.	N26	9.277	RELAY, A C CMPR	10034222
	N26	9.277	BRACKET, A C CONT RLY (3 900)	10022615
	N26	9.277	LATCH, A C CONT RLY (3 900)	10023153
7.	B9	3.900	RELAY, F/PUMP(9 277)	10034222
	B9	3.900	BRACKET, F/PUMP RLY	10022615
	B9	3.900	LATCH, F/PUMP RLY	10023153
8.	A20	3.403	NUT, A/CLNR	10031019
9.		N.S.	ADAPTER, AIR INT DUCT (1985)	
10.	A20	3.417	DUCT, THROT BODY TO ADAP (1985)	10154784
	A20	3.417	DUCT, THROT BODY TO ADAP (1986-88)	10154781
11.		8.948	CLAMP, AIR INT DUCT RR	25527699
12.	N19	1.745	GROMMET, CR/CASE VENT TUBE CONN TO RKR CVR	10137083
13.		N.S.	CONNECTOR, CR/CASE VENT TUBE TO RKR CVR FRT GROM	
14.		8.948	CLAMP, WORM GEAR (62 TO 1 25)	12337891
15.		N.S.	HOSE, CR/CASE VENT TUBE (TO CONNJ)	
16.	N19	1.762	TUBE, CR/CASE VENT TO FRT OF DA (1ST DES)(1985)(*)1	10038325
	N19	1.762	TUBE, CR/CASE VENT TO FRT OF DA (2ND DES)(1985-88)(*)2	10041473
17.		3.407	CLAMP, AIR INT DUCT RR (1 166)	10040194
18.	A17	3.402	AIR CLEANER, REM (1985)(*)3	25043488
	A17	3.402	AIR CLEANER, REM (1986-88)	25095512
	A24	3.682	SENSOR, A/CLNR AIR TEMP	25036751
19.	A20	3.403	STUD, A/CLNR TO SUPT	10033695
20.	A20	3.405	SUPPORT, A/CLNR	10033705
21.	A20	3.417	DUCT, A. CLNR TO AIR INT DUCT	10042033
22.	A24	3.682	SENSOR, VEH SPD (TRANS MT)(M T)	25007714
23.	C11	4.338	RETAINER, VEH SPD SEN (M T)	3708148
24.	C11	4.338	SEAL, VEH SPD SEN (M T)	484885
25.	A24	3.682	SENSOR, VEH SPD (TRANS MT)(A T)	25007268
26.	C11	4.338	SEAL, O RING, SPD SEN (A T)	8822076
27.	C11	4.338	RETAINER, VEH SPD SEN (A T)	25513329
28.	A20	3.417	DUCT, AIR INT WAT SEP	10044264
	A20	3.417	DUCT, FRT AIR INT (TO QTR PNL)	10030240
	A20	3.417	BRACKET, FRT AIR INT DUCT LWR	10030462
	A20	3.417	BRACKET, FRT AIR INT DUCT UPR	10030451
29.	N17	1.055	RELAY, ENG COOL FAN (2 STAGE FAN)	10040131
30.	N17	1.055	RELAY, ENG COOL FAN (EXC H D C)(1985 87)	10038311
	N17	1.055	RELAY, ENG COOL FAN (1988)	14089936
31.	A24	3.675	STUD, EGR VLV PIPE TO ADAP MANIF	10037691
32.	A24	3.680	TUBE, EGR VLV ADAP	10137017
	A24	3.680	TUBE, EGR VLV ADAP (1988)	10137021
33.	A23	3.671	GASKET, EGR V. V TRFR TUBE (66MM LG)	10038300
34.	A23	3.671	STUD, EGR VLV TO ADAP	10034956
35.	A23	3.671	GASKET, EGR VLV ADAP TO EXH CR OVR	10038299
36.	A23	3.671	ADAPTER, EGR VLV	10034074
37.	A23	3.671	GASKET, EGR VLV TO ADAP	10038298
38.	A22	3.670	VALVE, EGR	17110813
39.	N19	1.745	GROMMET, CR CASE VENT VLV	10038281
40.	N19	1.745	VALVE, CR CASE VENT (CV892C)	25043843
41.	A17	3.338	HOSE, IDLE AIR CONN	10036758
42.	A12	3.335	GASKET, THROT BODY	10034146
43.	A12	3.335	THROTTLE BODY ASM(*)3	
44.	A17	3.338	PIPE, THROT BODY IDLE AIR	10038778
45.	A24	3.682	SENSOR, EXH OXYGEN (1985 87)	8880741
	A24	3.682	SENSOR, EXH OXYGEN (1988)	25105107
46.		8.948	CLAMP, WORM GEAR HEX SLOT SCREW (250 x 625) SS	25518880
47.		8.962	HOSE, ELEC VAC REG SOL VAC (7 32)	9439274
48.	A23	3.671	BRACKET, EGR ELEC VAC REG SOL VLV	10037149
49.		8.950	CLIP, C. SD S*, (7 16x5 16)	25528829
50.	A22	3.670	VALVE, EGR ELEC VAC REG SOL	10038324
51.	N18	1.150	BUSHING, CLNT TEMP GA SEN	10037037
	A24	3.682	SENSOR, CLNT TEMP (1 150)	25038979
53.	N19	1.800	SENSOR, F PUMP & O PRESS SW (1985 87)	10045775
	N19	1.800	SENSOR, F PUMP & O PRESS SW (1988)	1647135
54.	N19	1.803	PIPE, ENG OIL PRESS GA SEN (W A C)	10035770

55.		N.S.	FITTING, OIL PRESS SEN/PIPE	
56.	A24	3.662	SENSOR, M A P	16017460
57.		N.S.	RAIL ASM, FUEL (SERV BY CMPTSH*3)	
58.	A10	3.265	PLENUM, INT MANIF (1985-86)	10033120
	A10	3.265	PLENUM, INT MANIF (1987-88)	10044661
59.		N.S.	INJECTOR ASM, COLD START/SERV BY.	
	A11	3.329	VALVE KIT, COLD START	17110860
	A11	3.329	TUBE KIT, COLD START	17112065
60.	N17	1.055	SWITCH, FAN CONT	3040674
61.	A11	3.329	SWITCH, COLD START F/INJ	14084318
62.	A17	3.337	HOSE, THROT BODY HTR INT PIPE (CLNT)	10036760
63.	A17	3.337	PIPE, THROT BODY CLNT SPLY & RTN	10040107
64.	N18	1.166	CLAMP, WORM TYPE (56" TO 1 06" DIA)	22518665
65.	A17	3.337	HOSE, THROT BODY HTR OTLT PIPE (CLNT)	10036761
66.	N22	2.525	HARNES, ENG/ECM WRG(*3)	
67.		6.962	HOSE, CNSTR PURGE (7/32)(PART OF ITEM 66)	
68.		6.962	HOSE, VPR CNSTR (5/32)	
69.	A9	3.120	PIPE, CNSTR PURGE (CNSTR TO ENG PURGE)	10042047
70.		6.962	HOSE, CNSTR VPR (5/16)	
71.		8.948	CLAMP, HOSE (SPR BAND)(562)	
72.	A9	3.130	CANISTER, FUEL VPR	17075840
73.	A9	3.130	SUPPORT, FUEL VPR CNSTR	10039220
74.	B8	3.883	SWITCH, CR/CONT VAC REL (BRK & CLU)	10024217
75.	B8	3.885	RETAINER, VAC REL VLV	10075405
76.		N.S.	HOSE, CR/CASE VENT TUBE TO A/CLNR DUCT (1985)(*1)	
		N.S.	HOSE, CR/CASE VENT TUBE (1985-88)(*2)	
77.		8.964	TUBING, STL (1/4)	603827
78.		8.962	HOSE, FUEL OIL EVAP (1/4X24)	9438267
79.		8.946	CLAMP, WORM GEAR HEX SLOT SCREW (.250 X .625) SS	25518880
80.		8.964	TUBING (5/16X25)	1324714
81.	A9	3.162	CLIP, FUEL VPR PIPE	14020587
82.	A9	3.118	BRACKET, FUEL VPR TK (1987-88)	10041460
83.	A9	3.145	HOSE, FUEL VPR TK RR (1987-88)	10041463
84.	A9	3.118	TANK, FUEL VPR (1987-88)	10041456
85.	A9	3.162	CLIP, FUEL VPR PIPE TO CNSTR PURGE (4.686)	343438
86.	N26	9.750	FILTER, TACH SIGNAL	10040110

NOTE 1 1ST DES-PCV SYSTEM VENTED TO A/CLNR AIR INTAKE ADAP ELBOW

NOTE 2 2ND DES-PCV SYSTEM VENTED TO A/CLNR

NOTE 3 SEE RESPECTIVE GROUP FOR DETAILED ILLUSTRATED VIEW

2P03-003
041588

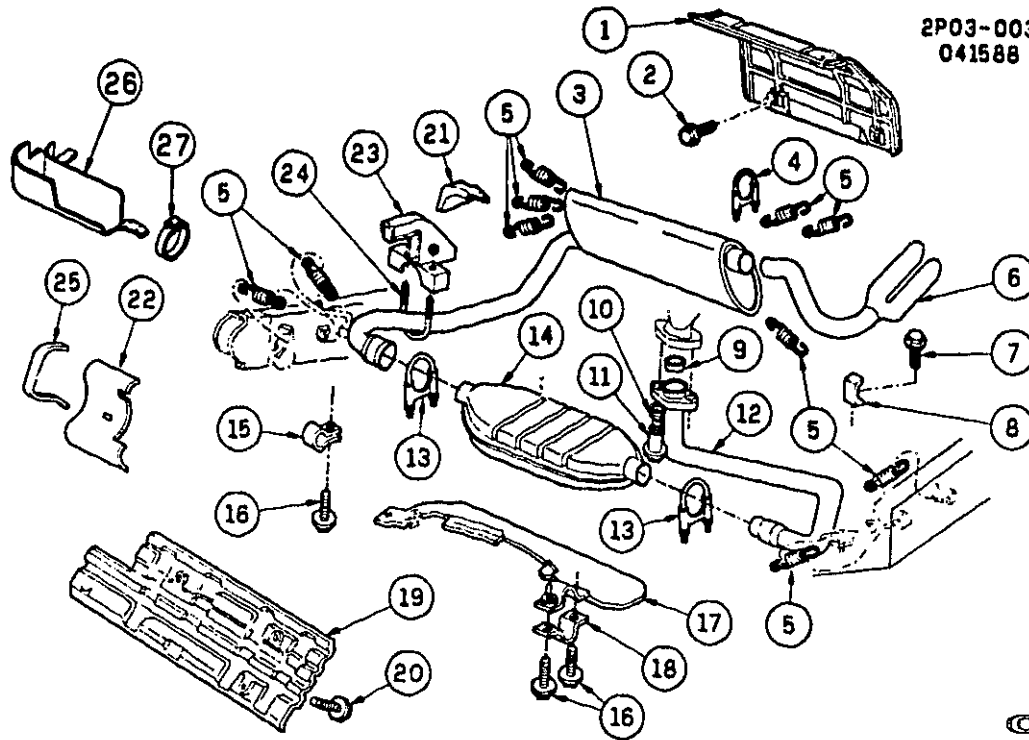

2P03-003

1984 P EXHAUST SYSTEM-L4 (LR8/2.5R EXC Y82)

1.	A26	3.705	SHIELD, MUFF HT	10035379
	N13	0.029	FRAME, (2 5R W/M T.H D SUSP.2 8-9)(1986)	10033670
2.	A25	3.690	SCREW, MUFF HT SHIELD (3 706)	10010688
3.	A25	3.701	MUFFLER, W/INTER PIPE (EXC Y82)	10048538
4.	A26	3.708	CLAMP, EXH SADDLE TYPE (50 8MM)(2")	1261589
5.	A26	3.704	SPRING, MUFF HNGR	10026939
6.	A26	3.705	PIPE, EXH TAIL & EXT (EXC Y82)	10038302
7.		8.900	SCREW, HWD TAP (M6 3 X 1 8 X 12)	10030900
8.	A26	3.704	BRACKET, EXH MUFF HNGR	10112097
9.	A22	3.611	SEAL, EXH MANIF PIPE	25501711
10.	A22	3.613	SPRING, EXH MANIF PIPE	10032758
11.	A22	3.611	BOLT, HFH W/SPL SHLDR (M10 X 1 5 X 71)	10032754
12.	A22	3.609	PIPE, FRT EXH (MANIF TO CONV)	15595208
13.	A26	3.708	CLAMP, SADDLE TYPE (FITS 60 32MM/2 375")	25056349
14.	A25	3.685	CONVERTER, CTLTC U-BOLT	10028097
15.	A25	3.690	CLAMP, CTLTC CONV SPH SHIELD-LH (53 0 MM)	10028096
16.		8.977	SCREW, HWD (#8-18 X 1")	10028491
17.	A25	3.690	SHIELD, CTLTC CONV SPH RR	10031566
18.	A25	3.690	CLAMP, CTLTC CONV SPH SHIELD-RH	10010688
19.	A25	3.690	SHIELD, CTLTC CONV HT	10032486
20.	A25	3.690	SCREW, CTLTC CONV HT SHLD (3 706)	10035978
21.	A26	3.704	BRACKET, MUFF HGR	10038058
22.	N20	2.042	SHIELD, START MTR	10036548
23.		N.S.	STOP, CONV	10041052
24.		N.S.	U BOLT, CONV STOP	
25.	N20	2.042	CLIP, START MTR SHLD	
26.	A22	3.616	SHIELD, START MTR HEAT (2 5R)	
27.		8.948	CLAMP, WORM GEAR (52 4 TO 74MM)SS	

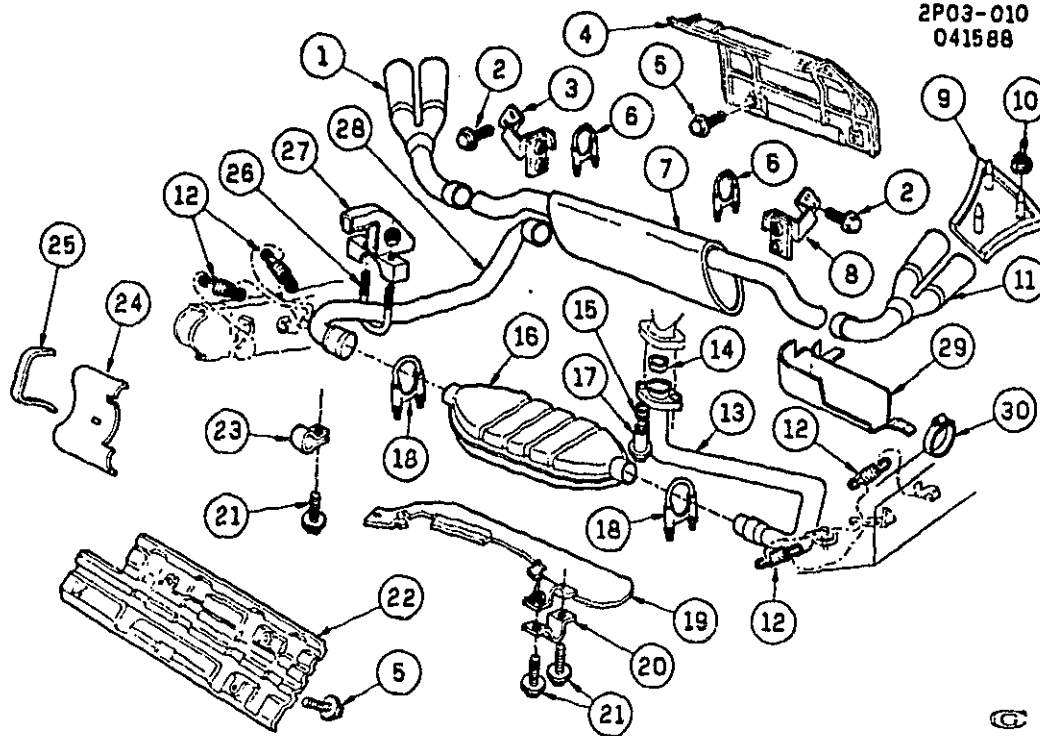

2P03-010

1984 P EXHAUST SYSTEM-L4 (LR8/2.5R W/Y82)

1.	A26	3.705	PIPE, TAIL-RH	10033872
2.		8.900	SCREW, HWH TAP (M6 3-1 8X12)	
3.	A26	3.708	HANGER, TAIL PIPE TO FRAME-RH	10035485
4.	A26	3.705	SHIELD, MUFF HT TO PNL RR COMPT	10035379
5.		8.977	SCREW, HWH (M4 2-1 41X10)	
6.	A26	3.708	CLAMP, EXH SADDLE TYPE (50 8MM)(2")	1261589
7.		N.S.	MUFFLER, EXH	
8.	A26	3.708	HANGER, TAIL PIPE TO FRAME-LH	10035486
9.	N24	7.831	SHIELD, RR BPR FASCIA EXT HT-RH	10037001
	N24	7.831	SHIELD, RR BPR FASCIA EXT HT-LH	10037002
10.		8.917	NUT, HFH (M10-1 5)	
11.	A26	3.705	PIPE, TAIL-LH	10033873
12.	A26	3.704	SPRING, MUFF HNGR	10026939
13.	A22	3.809	PIPE, FRONT EXHAUST(MANIF TO CONV)	10032754
14.	A22	3.811	SEAL, EXH MANIF PIPE	10112097
15.	A22	3.813	SPRING, EXH MFLD PIPE	25501711
16.	A25	3.885	CONVERTER, CTLTC	25056349
17.	A22	3.811	BOLT, EXH MANIF PIPE (M10X1 5X77)	10032756
18.	A26	3.708	CLAMP, SADDLE TYPE (FITS 60 32MM/2 375")	15595208
19.	A25	3.890	SHIELD, CTLTC CONV SPH RR	10028096
20.	A25	3.890	CLAMP, CTLTC CONV SPH SHLD-RH	10028491
21.		8.977	SCREW, HWH TAP (#8-18X1")	
22.	A25	3.890	SHIELD, CTLTC CONV HT	10031586
23.	A25	3.890	CLAMP, CTLTC CONV SPL SHLD-LH	10028097
24.	N20	2.042	SHIELD, START MTR	10035978
25.	N20	2.042	CLIP, START MTR SHLD	10038058
26.	A26	3.708	CLAMP KIT, EXH SADDLE TYPE (50 8MM)(2")	1261589
27.	A22	3.816	STOP, EXH PIPE	10033779
28.		N.S.	PIPE, INTER	
29.	A22	3.818	SHIELD, START MTR HEAT (2 5R)	10036548
30.		8.948	CLAMP, WORM GEAR (52 4 TO 74MM)SS	10041052

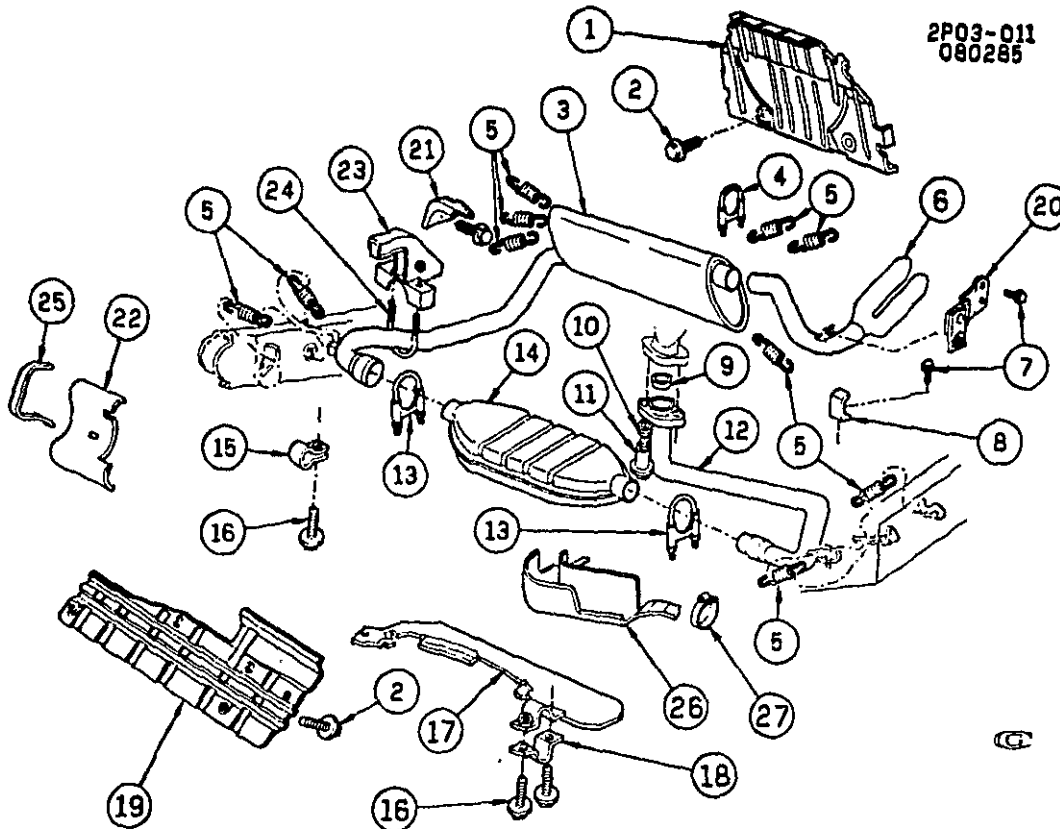

2P03-011

1985-1987 P EXHAUST SYSTEM-L4 (LR8/2.5R)

1.	A26	3.705	SHIELD, MUFF HT TO PNL RR COMPT	10035379
2.	A26	8.977	SCREW, HWH TAP (M4.2X1 41X16) PZOR	11509135
3.	A25	3.701	MUFFLER, W/WINTER & EXH PIPE	10048536
	A25	3.701	MUFFLER, W/WINTER & TAIL PIPE (1987)	10053759
4.	A26	3.708	CLAMP KIT, EXH SADDLE TYPE	
5.	A26	3.704	SPRING, MUFF HNGR	10026939
6.	A26	3.705	PIPE, TAIL-W/EXT (1986)	10038302
7.	A26	8.977	SCREW, HWH TAP (M8X1 25X25)	11504688
8.	A26	3.704	BRACKET, MUFF HNGR	10030900
9.	A22	3.611	SEAL, EXH MANIF PIPE	10112097
10.	A22	3.613	SPRING, EXH MANIF PIPE	25501711
11.	A22	3.611	BOLT, EXH MANIF PIPE (M10X1 5X77) 9 8 PC	10032768
12.	A22	3.609	PIPE, EXH (MANIF TO CONV)(1985-86)	10032754
13.	A26	3.708	CLAMP, EXH SADDLE TYPE	1281589
14.	A25	3.685	CONVERTER, CTLTC (1985-86)	25058349
	A25	3.685	CONVERTER, W/EXH MANIF PIPE (1987)	10044154
15.	A25	3.690	CLAMP, CTLTC CONV SPL SHLD-LH (1985-86)	10028097
16.	A25	8.977	SCREW, HWH (M4 2X1 41X16)	11509374
17.	A25	3.690	SHIELD, CTLTC CONV SPH RR (1985)	10028098
18.	A25	3.690	CLAMP, CTLTC CONV SPH SHLD (1985)	10028491
19.	A25	3.690	SHIELD, CTLTC CONV HT TO PNL FLR PAN	10039201
20.	A26	3.708	HANGER, TAIL PIPE (1985-86)	10036999
21.	A26	3.704	BRACKET, MUFF HNGR-SPR TO CRADLE-RH	10032488
22.	N20	2.042	SHIELD, START MTR HEAT	10035978
23.	A22	3.616	STOP, EXH PIPE (1985-86)	10033779
24.	A26	3.708	CLAMP KIT, EXH SADDLE TYPE (50 BMM)(2")	1281589
25.	N20	2.042	CLIP, START MTR HEAT SHLD	10038058
26.	A22	3.616	SHIELD, START MTR HEAT (1985-86)	10036548
27.	N20	2.042	CLAMP, START MTR HT SHIELD (1 166)(1985-86)	10041052
	N20	2.042	CLIP, START MTR SHLD (1987)	10036058

2P03-024
072087

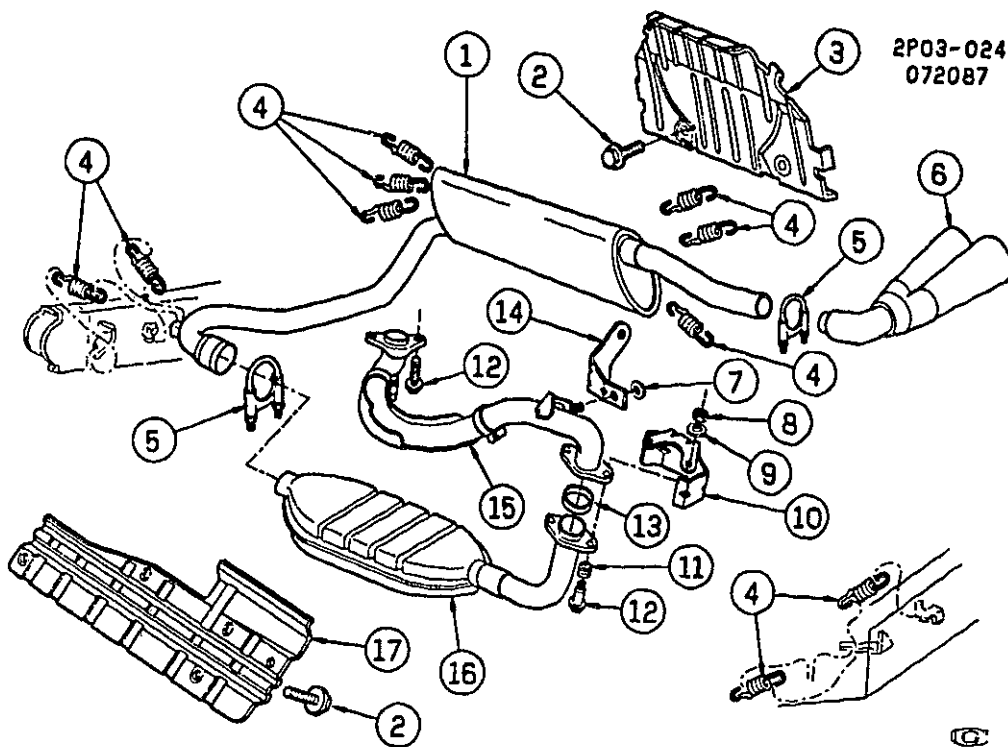

2P03-024

1988 P EXHAUST SYSTEM-L4 (LR8/2.5R)

1.	A25	3.701	MUFFLER, W/INTER PIPE & TAIL PIPE	10089649
2.	A25	3.690	SCREW, CTLTC CONV HT SHLD (3.706)	10010868
3.	A26	3.705	SHIELD, MUFF HT TO PNL RR COMPT	10035379
4.	A26	3.704	SPRING, MUFF HNGR	10028939
5.	A26	3.708	CLAMP, EXH (SADDLE TYPE)(FITS 50.80MM/2 00" PIPE)	1261589
6.	A28	3.705	PIPE, TAIL W/EXT (BLA)	10113185
7.		8.917	NUT, FLG HEX HD (M10X1.5)	11502812
8.		8.915	NUT, HEX (M10X1.5X9)10 CD	11505057
9.		8.931	WASHER, MED SPR LOCK (7/16")CAD OR ZC	120383
10.	A22	3.602	SHIELD, EXH MANIF PIPE HT	10113136
11.	A22	3.613	SPRING, EXH MANIF PIPE	25501711
12.	A22	3.613	BOLT, HEX (M10 X1.5X40)SS	10012853
13.	A22	3.611	SEAL, EXH MANIF PIPE	10131803
14.	A22	3.616	HANGER, EXH MANIF PIPE (1988)	10052110
15.	A22	3.609	PIPE, EXH MANIF (1988)	10052156
16.	A25	3.685	CONVERTER, W/EXH MANIF PIPE, CTLTC	10089652
17.	A25	3.690	SHIELD, CTLTC CONV HT (ATT TO FLR PNL)	10039201

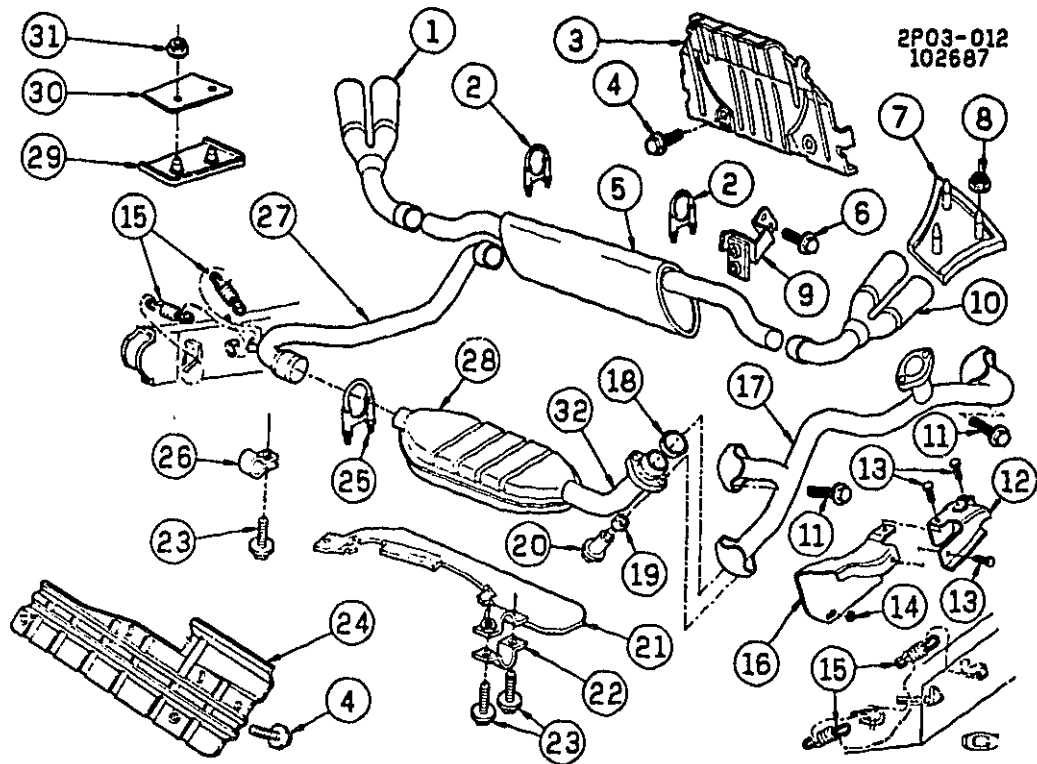

2P03-012

1985-1988 P EXHAUST SYSTEM-V6 (L44/2.8-9)

1.	A26	3.705	PIPE, TAIL-W/EXTEN-RH (BLA)(1985 W69)	10040188
	A26	3.705	PIPE, TAIL-W/EXTEN-RH (BRT S/STL (1985 WU2)	10040186
	A26	3.705	PIPE, TAIL-W/EXTEN-RH (BRT S/STL (1986-87)	10040186
	A26	3.705	PIPE, TAIL W/EXTEN (BRT S/STL (1988)	10081667
	A26	3.705	PIPE, EXH TAIL (W66)(1988)	10080710
2.	A26	3.708	CLAMP, EXH SADDLE TYPE (50 8MM)(2")	1261569
3.	A26	3.705	SHIELD, MUFF HT TO PNL RR COMPT	10035379
4.		8.900	SCREW, HWH (M4 2X1.41X10)	
5.	A25	3.701	MUFFLER, EXH (INCL'S #27)(1985-86)	14105910
	A25	3.701	MUFFLER, W/INTER PIPE & TAIL PIPES (1987)	10087393
	A25	3.701	MUFFLER, W/INTER PIPE & TAIL PIPE (1988)	10089850
6.		8.977	SCREW, HWH TAP (M6.3X1 81X13) PZOR	
7.	N24	7.831	SHIELD, RR BPR FASCIA HT-LH (1986-87 WU2)	10040021
	N24	7.831	SHIELD, RR BPR FASCIA HT-RH (1986-88 PG97)	10039516
	N24	7.831	SHIELD, RR BPR FASCIA HT-LH (1986-87 P37 WU2)	10040022
	N24	7.831	SHIELD, RR BPR FASCIA HT-LH (1986-88 P97)	10039517
8.		8.917	NUT, HFH (M10X1.5)	
9.	A26	3.708	HANGER, EXH TAIL PIPE-RH	10040190
	A26	3.708	HANGER, EXH TAIL PIPE-LH	10040189
	A26	3.708	HANGER, TAIL PIPE-RH (1987)	10044158
	A26	3.708	HANGER, TAIL PIPE-LH (1987)	10044157
10.	A26	3.705	PIPE, TAIL-W/EXTEN-LH (BLA)(1985 W69)	10113185
	A26	3.705	PIPE, TAIL-W/EXTEN-LH (BRT S/STL)(1985 WU2)(1986-87)	10044135
	A26	3.705	PIPE, TAIL-W/EXTEN-LH (BLA)(1987-88)(W69)	10113185
11.		8.900	BOLT, HFH M8X1 25X50 10.9 POR(BOLT, EXH C/OVR PIPE TO MANIF (3.609)(AR)	11508535
				10035889
12.	A22	3.602	SHIELD, C/OVR PIPE HT-RH	
13.		8.977	SCREW, HWH (M4 2X1.41X13) PC	
14.		8.917	NUT, TORX PREV HWH (M10X1.5)	
15.	A26	3.704	SPRING, MUFF HNGR	10026939
16.	A22	3.602	SHIELD, C/OVR PIPE HT-LH	10040105
17.	A22	3.609	PIPE, EXH C/OVR	10053721
18.	A22	3.611	SEAL, C/OVR PIPE	25623858

19.	A22	3.613	SPRING, EXH MANIF PIPE	25501711
20.	A22	3.611	BOLT, EXH MANIF PIPE (M10X1 5X77)	10032756
21.		N.S.	SHIELD, CTLTC CONV SPH	
22.	A25	3.690	CLAMP, CTLTC CONV SPH SHLD-LH	10035423
23.		8.977	SCREW, HWH (#8-18X1")	
24.	A25	3.690	SHIELD, CTLTC CONV HT TO PNL FLR PAN	10039201
25.	A26	3.708	CLAMP, SADDLE TYPE (FITS 60 32MM/2 375")	15595208
26.	A25	3.690	CLAMP, CTLTC CONV SPL SHLD-LH	10028097
27.		N.S.	PIPE, INTER (PART OF #5)	
28.	A25	3.685	CONVERTER, CTLTC (1985-86)	25127001
	A25	3.685	CONVERTER, CTLTC (INCLS #32)(1987)	10087392
	A25	3.685	CONVERTER, W/EXH MANIF PIPE.CTLTC (1988)	10089851
29.	N24	7.831	SHIELD, RR BPR FASCIA HT-RH (1986-88 P97)	10039518
	N24	7.831	SHIELD, RR BPR FASCIA HT-LH (1986-88 P97)	10039517
	N24	7.831	SHIELD, RR BPR FASCIA HT-RH (1986-87 P37 W/W69)	10040022
	N24	7.831	SHIELD, RR BPR FASCIA HT-LH (1985 W/WU2)	10040022
30.	N24	7.831	SPACER, RR BPR FASCIA (1986-88 P97)	10051833
31.		8.915	NUT, HFH W/NYLON INSERT (M6X1) 9 PEO	11508382
32.	A22	3.609	PIPE, EXH MANIF (1985-86)	14101400
		N.S.	PIPE, EXH MANIF (1987-88)(PART OF #28)	

PONTIAC CHASSIS GROUP 4.000

ILLUSTRATION INDEX

TITLE	GRID
1984	P 4-SPEED MANUAL TRANSAXLE (MY8/M19) H8
1985-1988	P 4-SPEED MANUAL TRANSAXLE (MY8/M17) H9
1985-1988	P 5-SPEED MANUAL TRANSAXLE/SHIFTER PARTS (MT2)(ISUZU) H12
1985-1988	P 5-SPEED MANUAL TRANSAXLE/DIFFERENTIAL (MT2)(ISUZU) H13
1985-1988	P 5-SPEED MANUAL TRANSAXLE/CASE SEALS (MT2)(ISUZU) H14
1985-1988	P 5-SPEED MANUAL TRANSAXLE PART 1 (MT2)(ISUZU) H16
1986-1988	P 5-SPEED MANUAL TRANSAXLE PART 1 (MG2)(MUNCIE-282) H19
1986-1988	P 5-SPEED MANUAL TRANSAXLE PART 2 (MG2)(MUNCIE-282) H21
1984-1985	P SHIFT CONTROLS/MANUAL TRANSMISSION FLOOR H24
1985-1988	P SHIFT CONTROLS/MANUAL TRANSMISSION FLOOR (MT2) H25
1987	P SHIFT CONTROLS/MANUAL TRANSMISSION FLOOR (MG2) H26
1988	P SHIFT CONTROLS/MANUAL TRANSMISSION FLOOR (MG2) H27
1984-1988	P AUTOMATIC TRANSMISSION (MD9) THM125C CASE & RELATED PARTS I3
1984-1988	P AUTOMATIC TRANSMISSION (MD9) THM125C CASE W/DRIVE LINK & SPROCKET I4
1984-1988	P AUTOMATIC TRANSMISSION (MD9) THM125C PUMP & CONTROL VALVE I6
1984-1988	P AUTOMATIC TRANSMISSION (MD9) THM125C CASE COVER PARTS I8
1984-1988	P AUTOMATIC TRANSMISSION (MD9) THM125C INTERNAL POWER TRAIN PARTS I10
1984-1988	P AUTOMATIC TRANSMISSION (MD9) THM125C PARK LOCK & INSIDE DETENT LEVER I13
1985-1988	P AUTOMATIC TRANSMISSION (MD9) THM125C THROTTLE VALVE CABLE-2.8L V6 (L44/ 2.8-9) I14
1984-1985	P FILLER TUBE & OIL COOLER PIPES THM125C A.T. (MD9) I15
1986-1988	P FILLER TUBE & OIL COOLER PIPES THM125C A.T. (MD9) I16
1984	P SHIFT CONTROL/AUTOMATIC TRANSMISSION FLOOR I17
1985	P SHIFT CONTROL/AUTOMATIC TRANSMISSION FLOOR I18
1986-1988	P SHIFT CONTROL/AUTOMATIC TRANSMISSION FLOOR I19
1985-1987	P BRAKE BOOSTER/VACUUM (DUAL DIAPHRAGM)(MORAINÉ) I21
1988	P BRAKE BOOSTER/VACUUM (DUAL DIAPHRAGM)(MORAINÉ) I23
1985-1988	P BRAKE MASTER CYLINDER (MORAINÉ) I25
1984-1987	P BRAKE CALIPER/FRONT DISC I26
1984-1987	P BRAKE CALIPER/REAR DISC I27
1986-1987	P BRAKE CALIPER/FRONT DISC (5349 SERIES)(MORAINÉ) I28
1986-1987	P BRAKE CALIPER/REAR DISC (5748 SERIES)(MORAINÉ) J2
1988	P BRAKE CALIPER/FRONT DISC (48H SERIES)(MORAINÉ) J3
1988	P BRAKE CALIPER/REAR DISC (48H SERIES)(MORAINÉ) J4
1984-1985	P BRAKE PEDAL & MASTER CYLINDER MOUNTING J6
1986-1988	P BRAKE PEDAL & MASTER CYLINDER MOUNTING J8
1984-1987	P PARKING BRAKE SYSTEM J10
1988	P PARKING BRAKE SYSTEM J11

GM04-080
020383

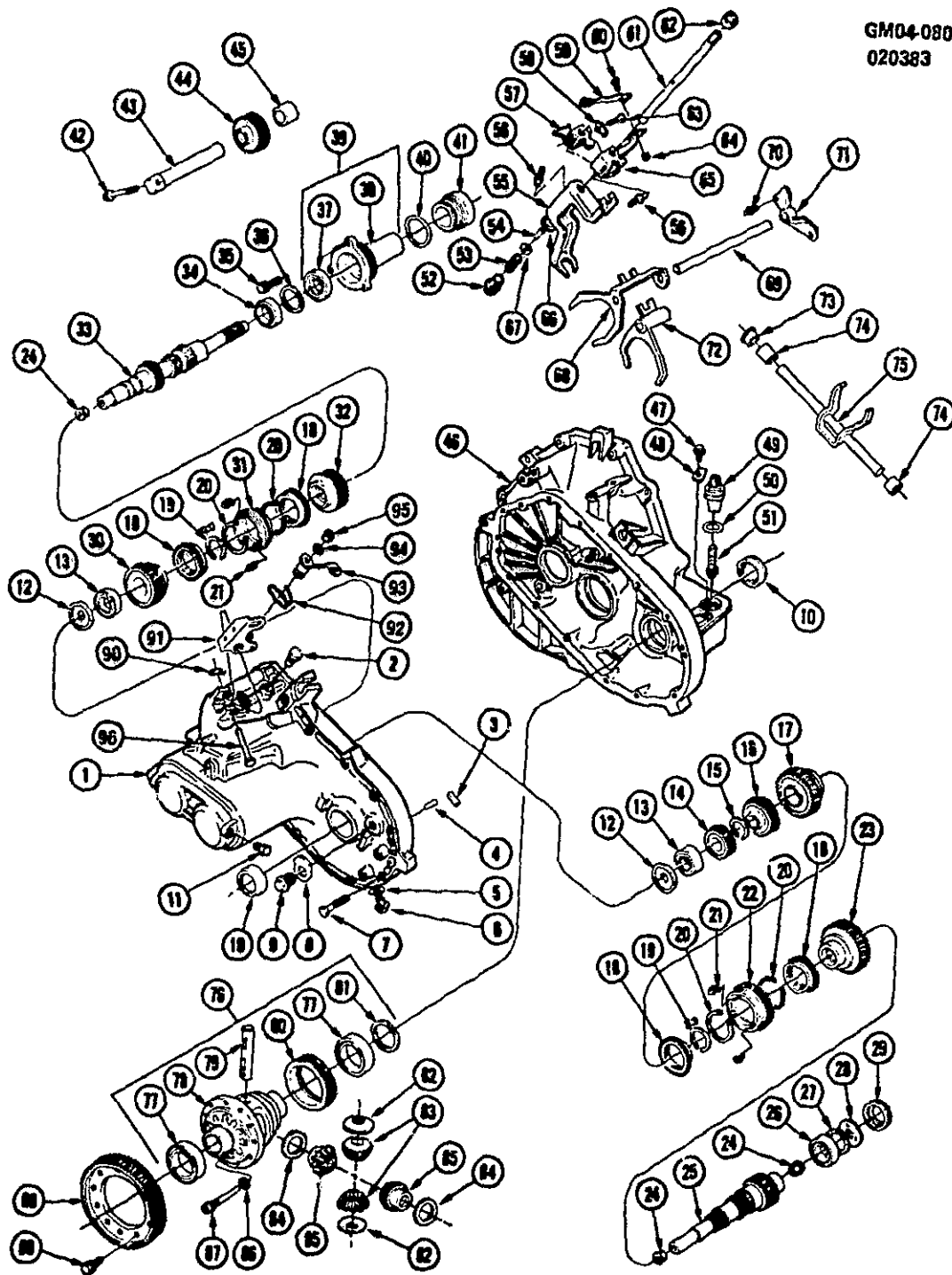

GM04-0802

1984 P 4-SPEED MANUAL TRANSAXLE (MY8/M19)

1.	C11	4.103	CASE ASM, TRANS	14071749
2.	C11	4.104	VENTILATOR, TRANS CASE	8640498
3.	C11	4.106	MAGNET, CHIP COLLECTOR	465474
4.	N13	0.685	PIN, CLU HSG	477231
5.		8.927	WASHER, DRAIN SCREW (M14X23X2)	
6.	C11	4.106	SCREW, DRAIN (M14X1 5X14 5)	14056604
7.		8.900	BOLT, HEX (M8X1 25X50)	
8.		8.927	WASHER, FILL PLUG (M20X29 5X2XNYLON)	
9.	C11	4.106	PLUG, FILL (M20X1 5)	476753
10.	E11	5.422	SEAL, AXLE OIL	8631156
11.		8.971	PLUG, SPL (1/4"-18X3 680)	
12.	C11	4.412	SHIELD, CASE BRG OIL	14008259
13.	C11	4.408	BEARING ASM, CASE	14091909
14.	C11	4.415	GEAR, 4TH SPD OUTPUT (MY8)	476723
	C11	4.415	GEAR, 4TH SPD OUTPUT (M19)	14086956
15.	C11	4.416	RING, 3RD SPD OUTPUT GR RET	464839
16.	C11	4.415	GEAR, 3RD SPD OUTPUT	14086961
17.	C11	4.395	GEAR, 2ND SPD OUTPUT	464837
18.	C11	4.383	RING, 1ST.2ND.3RD & 4TH SYN BLOCKING	14079923
19.	C11	4.384	RING, 1ST.2ND.3RD & 4TH SYN RET	464838
20.	C11	4.384	SPRING, 1ST.2ND.3RD & 4TH SYN	14086412
21.	C11	4.364	KEY, 1ST.2ND.3RD & 4TH SYN	14086424
22.	C11	4.380	SYNCHRONIZER ASM, 1ST & 2ND	14085536
23.	C11	4.417	GEAR, 1ST SPD OUTPUT	14085553
24.	C11	4.422	SLEEVE, OIL SHIELD (1984-85)	14020900
	C11	4.104	RETAINER, CASE BRG-THREADED (1985)	14073782
25.	C11	4.403	GEAR, OUTPUT (MY8 W/3 32R)	14079997
	C11	4.403	GEAR, OUTPUT (3 65R)	14079996
26.	C11	4.408	BEARING ASM, OUTPUT (6 311)	7450700
27.	C11	4.412	SHIM, OUTPUT GR BRG ADJ(*2)	463041
28.	C11	4.422	SHIELD, OUTPUT BRG OIL	14008258
29.	C11	4.422	RETAINER, OUTPUT GR BRG OIL SHIELD	476706
30.	C11	4.415	GEAR, 4TH SPD INPUT (M19)	14086956
	C11	4.415	GEAR, 4TH SPD INPUT (MY8)	476725
31.	C11	4.380	SYNCHRONIZER ASM, 3RD & 4TH	14085537
32.	C11	4.415	GEAR, 3RD SPD INPUT	14086960
33.	C11	4.421	GEAR, INPUT CLUSTER	14020899
34.	C11	4.355	BEARING, INPUT GEAR	9415132
35.		8.900	BOLT, HEX (M6X1X16)	
36.	C11	4.376	SHIM, INPUT GR BRG ADJ(*2)	
37.	C11	4.354	SEAL ASM, INPUT GEAR (ALSO PART OF #39)	476793
38.		N.S.	RETAINER, INPUT GEAR (PART OF #39)	
39.	C11	4.356	RETAINER ASM, INPUT GR BRG (INCL #37-38)	14020834
40.	C11	4.354	SEAL, INPUT GR BRG RETAINER	14020833
41.	N13	0.799	BEARING ASM, CLUTCH RELEASE	14091968
42.	C11	4.302	SCREW, W/WASHER REV IDLER	464858
43.	C11	4.433	SHAFT, REV IDLER	476724
44.	C11	4.430	GEAR ASM, REV IDLER	14079925
45.	C11	4.435	SPACER, REV IDLER SHAFT	14024949
46.	N13	0.683	HOUSING ASM, CLUTCH & DIFF	14071748
47.		8.900	SCREW, TAP (M6X1X16)	
48.	C11	4.338	RETAINER, SENSOR	3708148
49.	A24	3.682	SENSOR, SPEEDO DRIVEN GR	25007316
50.	C11	4.338	SEAL, SPEEDO GR SLEEVE	464865
51.		4.337	GEAR, DRN-29 TEETH (GRN)	10041031
		4.337	GEAR, DRN-30 TEETH (NAT)	10041032
		4.337	GEAR, DRN-30 TEETH (BLU)	25519845
		4.337	GEAR, DRN-31 TEETH (WHT)	25519846
52.	C11	4.311	SEAT, REV INHIBITOR SPRING	464866
53.	C11	4.311	SPRING, REV INHIBITOR	464867
54.	C11	4.311	PIN, SPR (M5X22)	14004884
55.	C11	4.302	LEVER, REVERSE SHIFT	14008271
56.	C11	4.302	STUD, REV LEVER LOC (MBX11 5)	14020895
57.	C11	4.050	LEVER, DETENT	14101494
58.	C11	4.302	WASHER, LOCK DETENT LEVER	474700
59.	C11	4.311	SPRING, DETENT	465436
60.	C11	4.311	BOLT, HEX (M6X1X14)	11503865
61.	C11	4.302	SHAFT, SHIFT	463091
62.	C11	4.311	SEAL ASM, SHIFT SHAFT	463024
63.	C11	4.032	BOLT, DETENT LVR (M6X1X31)	474699
64.		8.915	NUT, HEX (M6X1X5 1 THK)	
65.	C11	4.307	INTERLOCK, SHIFT	14046889
66.	C11	4.309	SHIM, SHIFT SHAFT(*2)	476709

87.	C11	4.311	WASHER, REV INHIBITOR SPRING	464868
88.	C11	4.303	FORK, 3RD & 4TH SHIFT	14009112
89.	C11	4.302	SHAFT, SHIFT FORK	463089
70.		8.977	SCREW, (M4 2X1 41X13)	
71.	C11	4.104	GUIDE, OIL	14009260
72.	C11	4.303	FORK, 1ST & 2ND SHIFT	14073789
73.	N14	0.805	SEAL ASM, CLUTCH FORK SHAFT	14092620
74.	N13	0.799	BEARING, CLU FORK SHF	474665
75.	N13	0.795	SHAFT, W/FORK. CLUTCH	14024930
76.		N.S.	DIFFERENTIAL ASM, (SERV BY COMPONENTS)	
77.	E14	5.636	BEARING ASM, DIFFERENTIAL	9437733
78.	E13	5.510	CASE, DIFF 3 34 RATIO (LESS GEARS)	14047636
79.	E13	5.517	SHAFT, DIFF PINION	463082
80.	C11	4.343	GEAR, SPC DR (35 TEETH)	8872319
81.	E14	5.537	SHIM, HSG BRG(* 2)	
82.	E15	5.542	WASHER, PINION THRUST(* 1)	463061
83.		N.S.	GEAR, DIFF PINION (3 34)(* 1)	
84.	E15	5.543	WASHER, DIFF SI GR THR(* 1)	14040531
85.	E14	5.528	GEAR, DIFF SIDE (3 34)(* 1)	14040530
86.		8.932	WASHER, LOCK (M8)	
87.	E13	5.518	SCREW, PINION SHAFT	463083
88.	E14	5.529	GEAR KIT, DIFF RING (3 32 RATIO)	14078563
	E14	5.529	GEAR, DIFF RING (4 10 RATIO)	14088744
89.		8.900	BOLT, (M10X1 50X20)(5 531)	
90.		8.934	RETAINER, SPRING (TYPE B)(1/16X7/16)	
91.	C11	4.045	LEVER, CONTROL SELECTOR	10030696
92.	C11	4.047	CLIP, SHIFT SHAFT ADJ	14048884
93.	C11	4.045	LEVER, SHIFT	10030028
94.	C11	4.046	WASHER, SHIFT LEVER	14091750
95.		8.915	NUT, HEX (M14X2)	
96.	C11	4.008	PIN, CONTROL SELECT LEVER	477095

NOTE 1 THESE PARTS ARE ALSO SERVICED IN 5 527 GEAR KIT 14045031

NOTE 2 SEE CHART IN GROUP FOR USAGE

GM04-238
092785

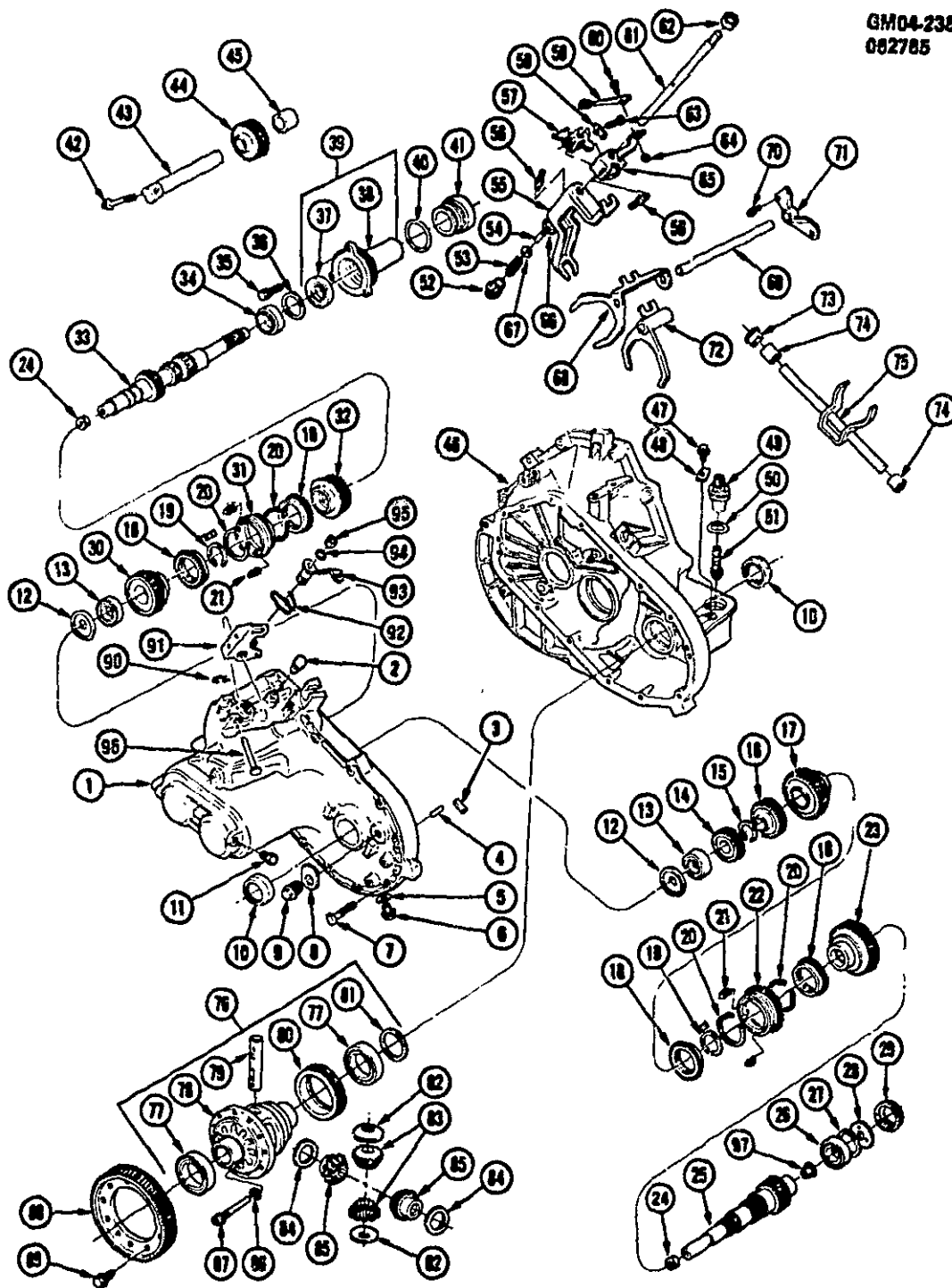

GM04-238

1985-1986 P 4-SPEED MANUAL TRANSAXLE (MY8/M17)

1.	C11	4.103	CASE ASM, TRANS	14071749
2.	C11	4.104	VENTILATOR, TRANS CASE	8640496
3.	C11	4.105	MAGNET, CHIP COLLECTOR	466474
4.	N13	0.685	PIN, CLU HSG	477231
5.		8.927	WASHER, DRAIN SCREW (M14X23X2)	
6.	C11	4.105	SCREW, DRAIN (M14X1 5X14 5)	14056604
7.		8.900	BOLT, HEX (M8 X 1 25X60)	
8.		8.927	WASHER, FILL PLUG (M20X29 5X2)(NYLON)	
9.	C11	4.105	PLUG, FILL (M20X1 5)	476753
10.	E11	6.422	SEAL, AXLE OIL (6 061)	8031156
11.		8.971	PLUG, SPL (1/4X18)(3 680)	
12.	C11	4.412	SHIELD, CASE BRG OIL	14008259
13.	C11	4.408	BEARING ASM, CASE	14091909
14.	C11	4.415	GEAR, 4TH SPD OUTPUT (MY8)	476723
	C11	4.415	GEAR, 4TH SPD OUTPUT (M19)	14086956
15.	C11	4.416	RING, 3RD SPD OUTPUT GR RET	464639
16.	C11	4.415	GEAR, 3RD SPD OUTPUT	14086961
17.	C11	4.395	GEAR, 2ND SPD OUTPUT	14085555
18.	C11	4.383	RING, 1ST.2ND.3RD & 4TH SYN BLOCKING	14079923
19.	C11	4.384	RING, 1ST 2ND 3RD & 4TH SYN RET	464636
20.	C11	4.384	SPRING, 1ST.2ND.3RD & 4TH SYN	14086412
21.	C11	4.384	KEY, 1ST.2ND.3RD & 4TH SYN	14086424
22.	C11	4.380	SYNCHRONIZER ASM, 1ST & 2ND (INCL #20 21)	14085536
23.	C11	4.417	GEAR, 1ST SPD OUTPUT	14085553
24.	C11	4.104	RETAINER, TRANS CASE BRG	14073782
25.	C11	4.403	GEAR, OUTPUT (MY8 W/3 32R)	14079997
	C11	4.403	GEAR, OUTPUT (3 65R)	14079996
26.	C11	4.408	BEARING ASM, OUTPUT (6 311)	7450700
27.	C11	4.412	SHIM, OUTPUT GR BRG ADJ(*2)	463041
28.	C11	4.422	SHIELD, OUTPUT BRG OIL	14008258
29.	C11	4.422	RETAINER, OUTPUT GR BRG OIL SHIELD	476708
30.	C11	4.415	GEAR, 4TH SPD INPUT (M19)	14086956
	C11	4.415	GEAR, 4TH SPD INPUT (MY8)	476725
31.	C11	4.380	SYNCHRONIZER ASM, 3RD & 4TH (INCL #20.21)	14085537
32.	C11	4.415	GEAR, 3RD SPD INPUT	14086960
33.	C11	4.421	GEAR, INPUT CLUSTER	14020899
34.	C11	4.356	BEARING, INPUT GEAR	9415132
35.		8.900	BOLT, HEX (M6X1X16)	
36.	C11	4.376	SHIM, INPUT GR BRG ADJ(*2)	
37.	C11	4.354	SEAL ASM, INPUT GEAR (ALSO PART OF #39)	476793
38.		N.S.	RETAINER, INPUT GEAR (PART OF #39)	
39.	C11	4.356	RETAINER ASM, INPUT GR BRG (INCL #37-38)	14020834
40.	C11	4.354	SEAL, INPUT GR BRG RETAINER	14020833
41.	N13	0.799	BEARING ASM, CLUTCH RELEASE	14091966
42.	C11	4.302	SCREW, W/WASHER REV IDLER	464658
43.	C11	4.433	SHAFT, REV IDLER	476724
44.	C11	4.430	GEAR ASM, REV IDLER	14079925
45.	C11	4.435	SPACER, REV IDLER SHAFT	14024949
46.	N13	0.683	HOUSING ASM, CLUTCH & DIFF	14071748
47.		8.900	SCREW, TAP (M6X1X16)	
48.	C11	4.338	RETAINER, SENSOR	3708148
49.	A24	3.682	SENSOR, SPEEDO DRIVEN GR	25007316
50.	C11	4.338	SEAL, SPEEDO GR SLEEVE	464865
51.		4.337	GEAR, DRN-29 TEETH (GRN)	10041031
		4.337	GEAR, DRN-30 TEETH (NAT)	10041032
		4.337	GEAR, DRN-30 TEETH (BLU)	25519845
		4.337	GEAR, DRN-31 TEETH (WHT)	25519846
52.	C11	4.311	SEAT, REV INHIBITOR SPRING	464866
53.	C11	4.311	SPRING, REV INHIBITOR	464867
54.	C11	4.311	PIN, SPR (M5X22)	14004864
55.	C11	4.302	LEVER, REVERSE SHIFT	14008271
56.	C11	4.302	STUD, REV LEVER LOC (M8X11 5)	14020895
57.	C11	4.050	LEVER, DETENT	14101494
58.	C11	4.302	WASHER, LOCK DETENT LEVER	474700
59.	C11	4.311	SPRING, DETENT	465436
60.	C11	4.311	BOLT, HEX (M6X1X14)	11503865
61.	C11	4.302	SHAFT, SHIFT	463091
62.	C11	4.311	SEAL ASM, SHIFT SHAFT	463024
63.	C11	4.032	BOLT, DETENT LVR (M6X1X31)	474699
64.		8.915	NUT, HEX (M6X1X5 * THK)	
65.	C11	4.307	INTERLOCK, SHIFT	14046669
66.	C11	4.309	SHIM, SHIFT SHAFT(*2)	476709
67.	C11	4.311	WASHER, REV INHIBITOR SPRING	464868

68.	C11	4.303	FORK, 3RD & 4TH SHIFT	14009112
69.	C11	4.302	SHAFT, SHIFT FORK	463089
70.		6.977	SCREW,(M4 2X1 41X13)	
71.	C11	4.104	GUIDE, OIL	14008260
72.	C11	4.303	FORK, 1ST & 2ND SHIFT	14073789
73.	N14	0.805	SEAL ASM, CLUTCH FORK SHAFT	14092820
74.	N13	0.799	BEARING, CLU FORK SHF	474665
75.	N13	0.795	SHAFT, W/FORK. CLUTCH	14024930
76.		N.S.	DIFFERENTIAL ASM,(SERV BY COMPONENTS)	
77.	E14	5.536	BEARING ASM, DIFFERENTIAL	9437733
78.	E13	5.510	CASE, DIFF 3 34 RATIO (LESS GEARS)	14047636
79.	E13	5.517	SHAFT, DIFF PINION	463082
80.	C11	4.343	GEAR, SPD DR (35 TEETH)	8672319
81.	E14	5.537	SHIM, HSG BRG(*2)	
82.	E15	5.542	WASHER, PINION THRUST(*1)	463081
83.		N.S.	GEAR, DIFF PINION (3 34X*1)	
84.	E15	5.543	WASHER, DIFF SI GR THR(*1)	14040531
85.	E14	5.528	GEAR, DIFF SIDE (3 34X*1)	14040530
86.		8.932	WASHER, LOCK (M8)	
87.	E13	5.518	SCREW, PINION SHAFT	463083
88.	E14	5.529	GEAR KIT, DIFF RING (3 32 RATIO)	14078563
	E14	5.529	GEAR, DIFF RING (4 10 RATIO)	14088744
89.		8.900	BOLT,(M10X1 50X20R5 531)	
90.		8.934	RETAINER, SPRING (TYPE BK1-16X7,16)	
91.	C11	4.045	LEVER, CONTROL SELECTOR	10035025
92.	C11	4.047	CLIP, SHIFT SHAFT ADJ	14046884
93.	C11	4.008	LEVER, SHIFT	10035021
94.	C11	4.046	WASHER, SHIFT LEVER	14091790
95.		8.915	NUT, HEX (M14X2)	
96.	C11	4.008	PIN, CONTROL SELECT LEVER	477095
97.	C11	4.422	SLEEVE, OIL SHIELD (1984-85)	14020900

NOTE 1 THESE PARTS ARE ALSO SERVICED IN 5 527 GEAR KIT 14045031
NOTE 2 SEE CHART IN GROUP FOR USAGE

GM04-176
100786

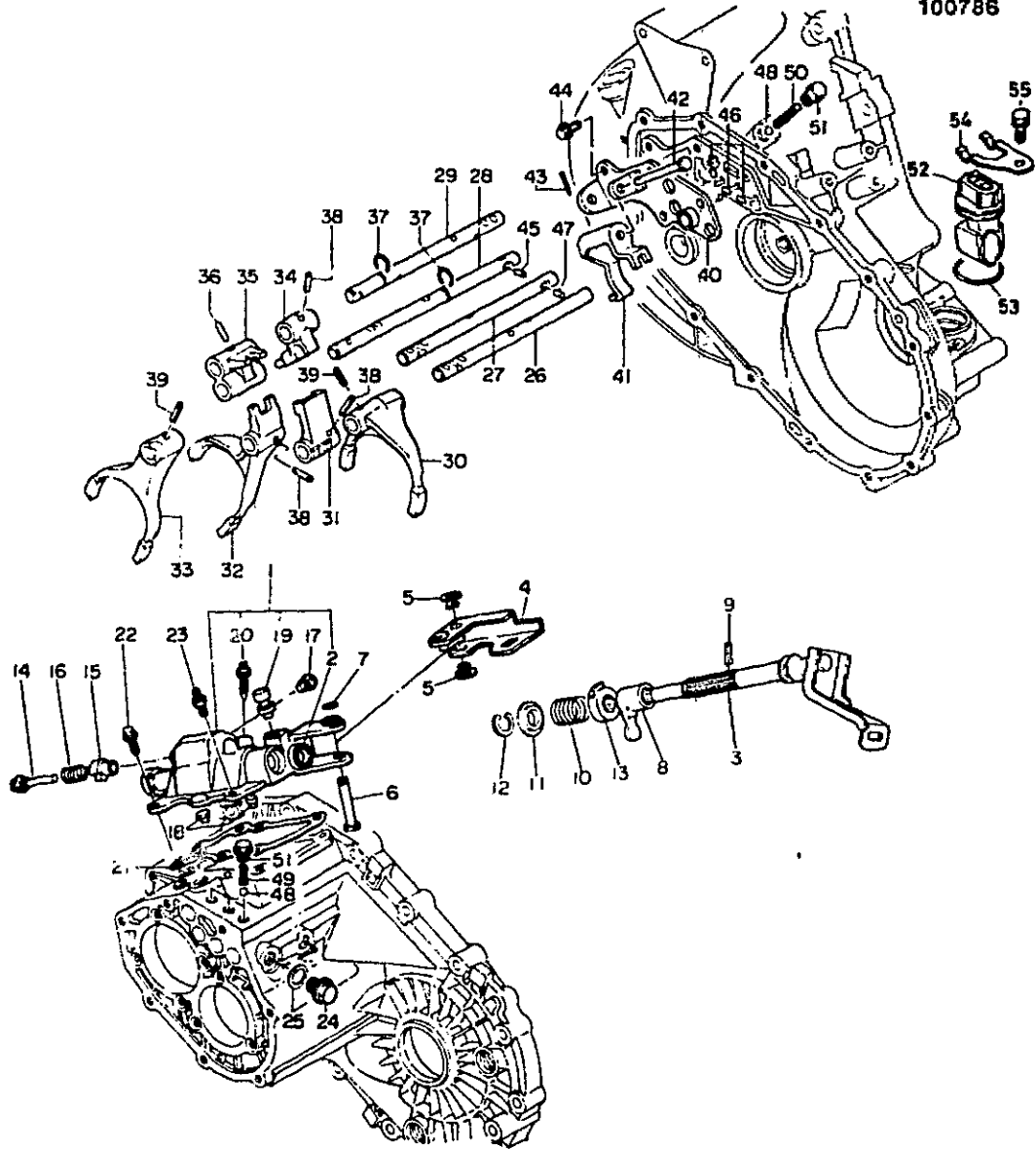

GM04-1781

1985-1988 P 5-SPEED MANUAL TRANSAXLE/SHIFTER PARTS (MT2)(ISUZU)

1.	C11	4.020	BOX, QUADRANT SHFT CONT (1985-87 SUB ASM)	94414387
	C11	4.020	BOX, QUADRANT SHFT CONT (1988-SUB ASM)	94477889
2.	C11	4.027	SEAL, QUADRANT BOX OIL	94145808
3.	C11	4.030	LEVER, EXT SHFT	94149858
4.	C11	4.045	LEVER, EXT SELECT (1985-87)	10088490
	C11	4.045	LEVER, EXT SELECT (1988)	94477071
5.	C11	4.032	BUSHING, SELECT LVR	94249510
6.	C11	4.032	PIN, SELECT LVR	94250117
7.		8.934	RING, SNAP (M6)	11514578
8.	C11	4.027	LEVER, INTERNAL SHFT	94149882
9.	C11	4.027	PIN, INTERNAL LVR SPR	94250113
10.	C11	4.027	SPRING, SELECT STOP-1ST & 2ND	94182935
11.	C11	4.027	SEAT, SPRING SELECT STOP	94257825
12.		8.934	RING,INT SNAP-FITS BORE SIZE (M16)	
13.	C11	4.030	STOPPER, REV INHIBITOR	94121950
14.	C11	4.032	BOLT, REV INHIBITOR	94120574
15.	C11	4.027	CAM, REV INHIBITOR STOPPER	94149884
16.	C11	4.027	SPRING, STOPPER CAM	94182589
17.	C11	4.032	BOLT, STOPPER CAM	94120573
18.	C11	4.020	PIN, QUADRANT BOX KNOCK	94250119
19.	C11	4.104	VENTILATOR, QUADRANT BOX	94255849
20.	C11	4.027	STUD, NEU POSN SET	94149883
21.	C11	4.015	GASKET, QUADRANT BOX	94249518
22.	C11	4.012	BOLT, QUADRANT BOX	94250104
23.	C11	4.012	BOLT, QUADRANT BOX STUD	94151793
24.	C11	4.104	SCREW, TRANS CASE PLUG	94252142
25.	C11	4.075	GASKET, TRANS CASE PLUG	94020241
26.	C11	4.309	SHAFT, GR SHFT ARM-1ST & 2ND	94147987
27.	C11	4.309	SHAFT, GR SHFT 3RD & 4TH ARM	94253912
28.	C11	4.309	SHAFT, GR SHFT ARM 5TH	94257918
29.	C11	4.309	SHAFT, GR SHFT ARM REV	94257919
30.	C11	4.303	FORK, SHFT-1ST & 2ND (1985)	94316924
31.	C11	4.303	BLOCK, 1ST & 2ND SHFT	94249780
32.	C11	4.303	FORK, 3RD & 4TH SHFT	94464752
33.	C11	4.303	FORK, 5TH SHFT	94109002
34.	C11	4.303	LEVER, REV SHFT	94337879
35.	C11	4.303	BLOCK, REV & 5TH SHFT	94257920
36.	C11	4.307	PIN, LK INTLK G/S	94024889
37.	C11	4.307	RING, 5TH/REV SHFT SHF SNAP (1985-87)	94030873
	C11	4.307	RING, 5TH/REV SHFT SHF SNAP (1988)	94030873
38.	C11	4.303	PIN, SHFT ARM SPR	94171541
39.	C11	4.303	PIN, SHFT ARM SPR	94171541
40.	C11	4.302	BRACKET, REV LVR FULCRUM	94249771
41.	C11	4.302	LEVER, REV SHFT	94152567
42.	C11	4.302	PIN, REV SHFT FULCRUM BRKT	94250115
43.	C11	4.302	PIN, FULCRUM	94029875
44.	C11	4.302	BOLT, FULCRUM BRKT	94250107
45.	C11	4.302	PIN, 5TH SHF LK	94250114
46.	C11	4.307	PIN, INTER LK G/S	94024889
47.	C11	4.302	PIN, 3RD & 4TH SHF LK	94250116
48.		8.899	BALL, 5/16 STL	104919
49.	C11	4.311	SPRING, DETENT BALL	94251507
50.	C11	4.311	SPRING, DETENT BALL REV	94251508
51.	C11	4.307	PLUG, DETENT SPR	94251509
52.	A24	3.652	SENSOR ASM, SPEED	25007714
53.	C11	4.338	SEAL, VEH SPD SEN	464885
54.	C11	4.338	RETAINER, VEH SPD SEN	3708148
55.		8.900	BOLT, HFH (M6X1X1.3) POR (1985-87)	14083759
		8.900	BOLT, HEX (M6X1X1.6) 9 8 ZP (1988)	11500413

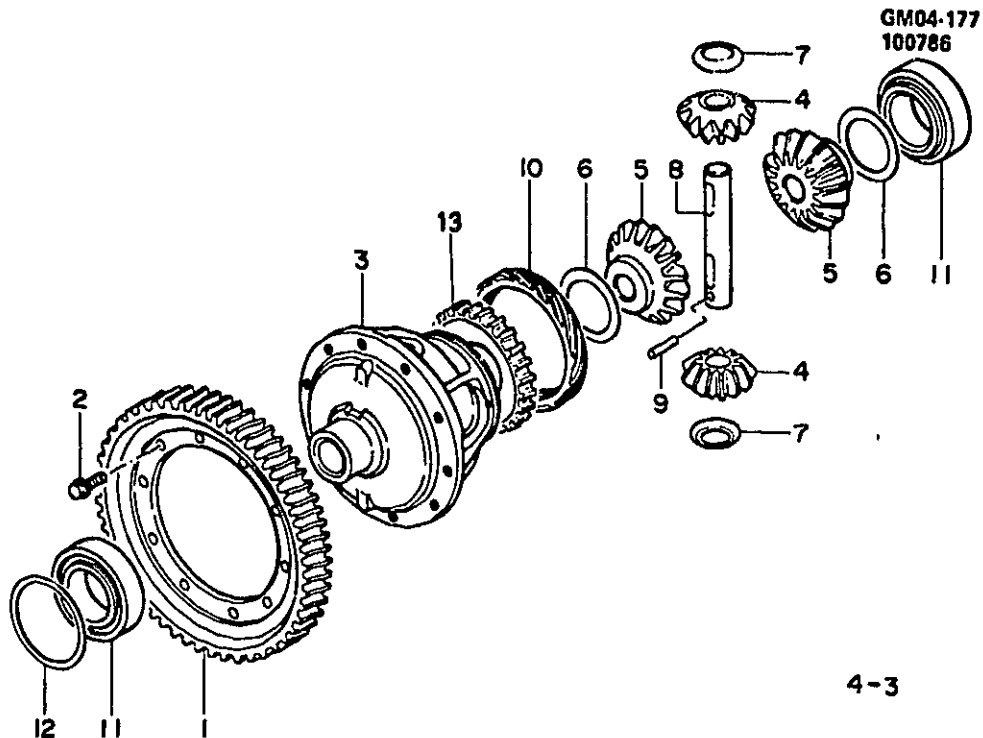

4-3

GM04-1771

1985-1988 P 5-SPEED MANUAL TRANSAXLE/DIFFERENTIAL (MT2)(ISUZU)

1.	E14	5.529	GEAR, DIFF RING (3 35R)	94149668
2.	E14	5.531	BOLT, RING GR	94127538
3.	E13	5.510	CASE, DIFF	94244546
4.	E13	5.510	DIFFERENTIAL	8672381
5.	E14	5.528	GEAR, DIFF SIDE(*1)	14076988
6.	E15	5.543	WASHER, DIFF SI GR THR(*1)	14040531
7.	E15	5.542	WASHER, PIN THR(*1)	463081
8.	E13	5.517	SHAFT, DIFF PIN(*1)	463082
9.	E13	5.518	PIN, PIN SHF LK	94250109
10.	C11	4.343	GEAR, SPEED DRIVE	94408341
11.	E14	5.538	BEARING, DIFF	94027665
12.	E14	5.537	SHIM, BRG DIFF SI (1 08MM)	94249545
	E14	5.537	SHIM, BRG DIFF SI (1 16MM)	94249546
	E14	5.537	SHIM, BRG DIFF SI (1 24MM)	94249547
	E14	5.537	SHIM, BRG DIFF SI (1 32MM)	94249548
	E14	5.537	SHIM, BRG DIFF SI (1 40MM)	94249549
	E14	5.537	SHIM, BRG DIFF SI (1 48MM)	94249550
	E14	5.537	SHIM, BRG DIFF SI (1 56MM)	94249551
	E14	5.537	SHIM, BRG DIFF SI (1 64MM)	94249552
	E14	5.537	SHIM, BRG DIFF SI (1 72MM)	94249553
	E14	5.537	SHIM, BRG DIFF SI (1 80MM)	94249554
	E14	5.537	SHIM, BRG DIFF SI (1 88MM)	94249555
	E14	5.537	SHIM, BRG DIFF SI (1 96MM)	94249556
13.	N.S.		ROTOR, SPEED SENSOR	

NOTE 1 PART OF 5 527 14045031 - GEAR KIT DIFF SI-W P.N

GM04-178
051884

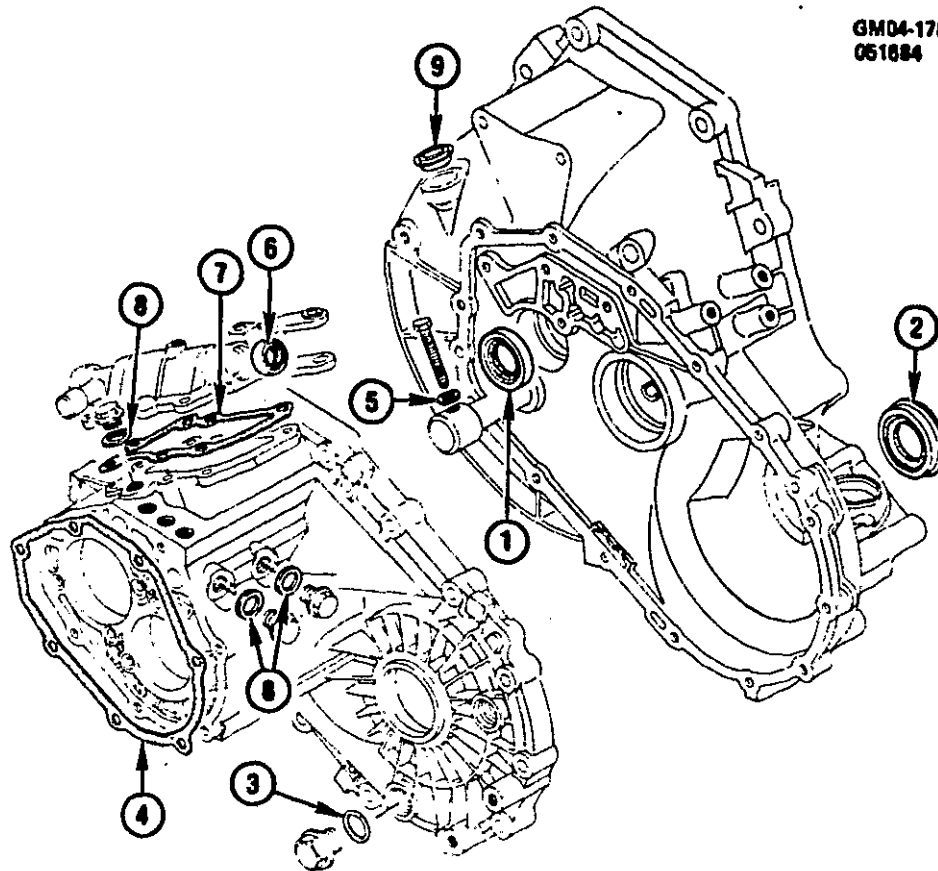

GM04-1781

1985-1988 P 5-SPEED MANUAL TRANSAXLE/CASE SEALS (MT2)(ISU ZU)

1. C11	4.354	SEAL, INPUT SHF(* 1)	94379067
2.	6.081	SEAL, DRIVE SHF OIL(* 1)	90342143
3. C11	4.105	O RING, TRANS OIL FLTR AND DRAIN(* 1)	94020128
4. C11	4.318	GASKET, CASE TO RR CVR(* 1)	94422618
5.	8.955	GASKET, COPPER FL (M10 2 X 16 X 1)(*)	94000373
6. C11	4.027	SEAL, QUADRANT BOX OIL(* 1)	94145908
7. C11	4.016	GASKET, QUADRANT BOX(* 1)	94249518
8. C11	4.075	GASKET, TRANS CASE PLUG(* 1)	94020241
9. N14	0.805	SEAL, CLU SHF(* 1)	14092820

NOTE 1 ALSO PART OF 4 005 94445605 GASKET KIT OVERHAUL

GM04-265
091286

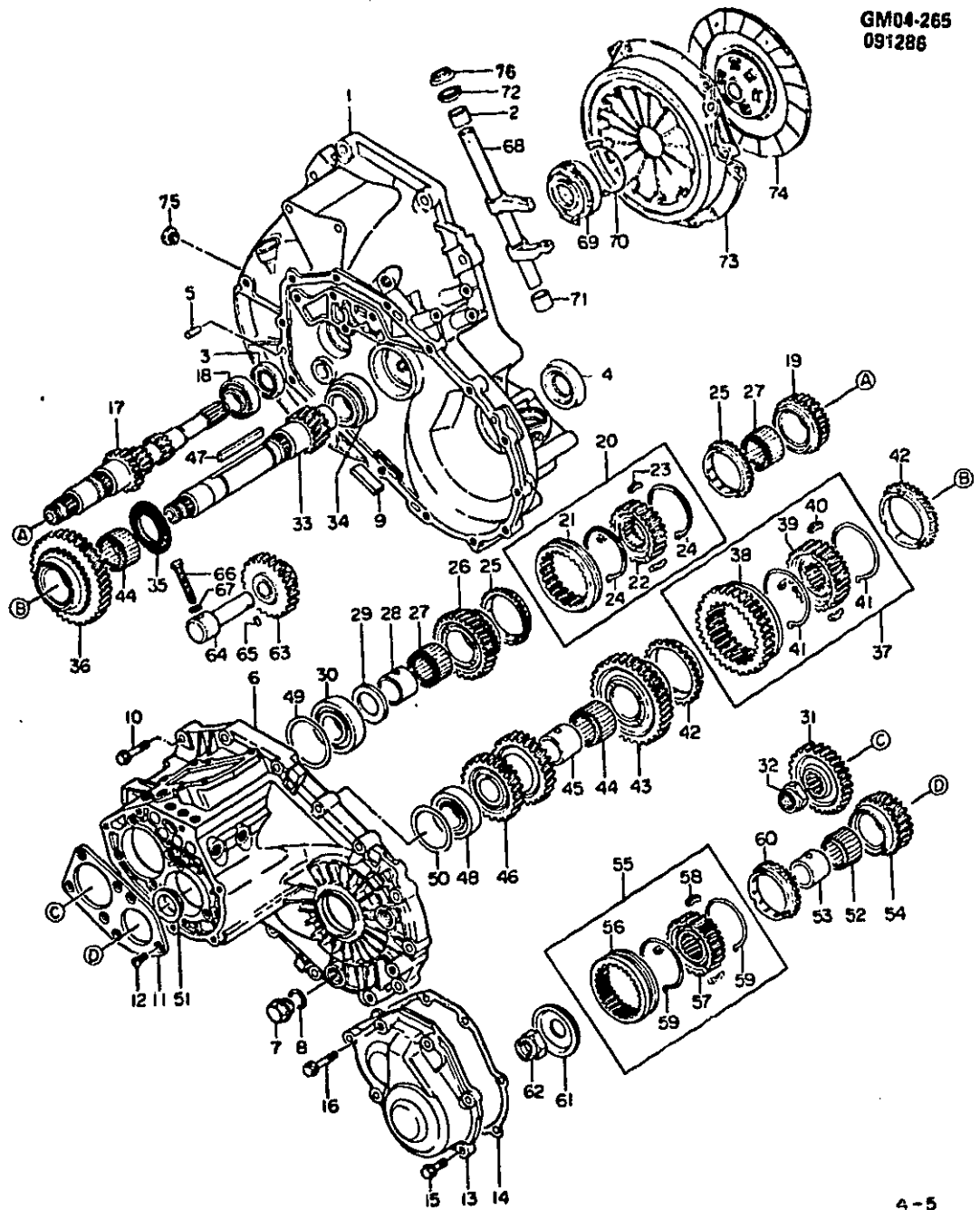

4-5

GM04-265

1985-1988 P 5-SPEED MANUAL TRANSAXLE PART 1 (MT2) (ISUZU)

1.	N13	0.683	HOUSING, CLU & DIFF	94433448
2.	N13	0.799	BEARING, CLU FORK SHF	474685
3.	C11	4.354	SEAL, INPUT SHF OIL	94379087
4.		6.061	SEAL, DRIVE SHF OIL	90342143
5.		6.939	PIN, STGHT SOLID (10MM DIA X 20MM)	94098216
6.	C11	4.103	CASE, TRANS (1985-86X*1)	94152585
	C11	4.103	CASE, TRANS (1986-88X*2)	94469503
7.	C11	4.105	PLUG, OIL DRAIN	94451478
8.	C11	4.105	O RING, TRANS OIL FLTR & DRAIN	94020128
9.	C11	4.105	MAGNET, CHIP COLLECTOR	465474
10.	C11	4.104	BOLT, HSG TO CASE	94250103
11.	C11	4.412	RETAINER, BRG	94469594
12.	C11	4.104	SCREW, RET TO TRANS CASE	94248159
13.	C11	4.317	COVER, RR (1985-86)	94249527
	C11	4.317	COVER, RR (1987-88)	94469501
14.	C11	4.318	GASKET, CASE TO RR CVR	94422616
15.	C11	4.319	BOLT, RR CVR TO CASE (27 MM)	94250105
16.	C11	4.319	BOLT, RR CVR TO CASE (42 MM)	94250106
17.	C11	4.412	SHAFT, INPUT	94310205
18.	C11	4.355	BEARING, INPUT SHF FRT	94249584
19.	C11	4.415	GEAR, 3RD INPUT (3 35R)	94149888
20.	C11	4.380	SYNCHRONIZER, 3RD & 4TH GEAR	94249573
21.		N.S.	SLEEVE, 3RD & 4TH SYN (PART OF #20)	
22.		N.S.	HUB, 3RD & 4TH CLU (PART OF #20)	
23.	C11	4.384	INSERT, 3RD & 4TH & 5TH GR SYN	94249576
24.	C11	4.384	SPRING, 3RD & 4TH INS	94249577
25.	C11	4.383	RING, 3RD & 4TH & 5TH GR BLOCKING	94249580
26.	C11	4.415	GEAR, 4TH INPUT	94139575
27.	C11	4.355	BEARING, 3RD & 4TH NDL	94465413
28.	C11	4.376	COLLAR, 4TH GR NDL BRG	94318287
29.	C11	4.415	WASHER, 4TH GR THR	94321336
30.	C11	4.408	BEARING, INPUT RR	94249810
31.	C11	4.415	GEAR, 5TH INPUT	94249812
32.	C11	4.422	NUT, 5TH GR (4 412)	94124014
33.	C11	4.403	SHAFT, OUTPUT	94148822
34.	C11	4.408	BEARING, OUTPUT SHF FRT	94249819
35.	C11	4.419	BEARING, NDL THR	94148936
36.	C11	4.417	GEAR, 1ST OUTPUT	94152548
37.	C11	4.380	SYNCHRONIZER, 1ST & 2ND	94152554
38.		N.S.	GEAR, REV & SLEV (PART OF #37)	
39.		N.S.	HUB, REV CLU (PART OF #37)	
40.	C11	4.384	INSERT, 1ST & 2ND GR SYN	94152557
41.	C11	4.384	SPRING, 1ST & 2ND INSERT	94152558
42.	C11	4.383	RING, 1ST & 2ND BLOCKING	94151610
43.	C11	4.415	GEAR, 2ND OUTPUT	94152551
44.	C11	4.355	BEARING, 1ST & 2ND GEAR	94465412
45.	C11	4.376	COLLAR, 2ND GR NDL BRG	94249838
46.	C11	4.415	GEAR, 3RD & 4TH OUTPUT	94249839
47.		6.950	KEY, (8MM SQUARE X 63) LONG STL PL	94008504
48.	C11	4.408	BEARING, OUTPUT RR	94249843
49.	C11	4.376	SHIM, INPUT SHAFT BRG (1 04MM THK)	94107682
	C11	4.376	SHIM, INPUT SHAFT BRG (1 12MM THK)	94107683
	C11	4.376	SHIM, INPUT SHAFT BRG (1 20MM THK)	94107684
	C11	4.376	SHIM, INPUT SHAFT BRG (1 28MM THK)	94107685
	C11	4.376	SHIM, INPUT SHAFT BRG (1 36MM THK)	94107686
	C11	4.376	SHIM, INPUT SHAFT BRG (1 44MM THK)	94107687
	C11	4.376	SHIM, INPUT SHAFT BRG (1 52MM THK)	94107688
	C11	4.376	SHIM, INPUT SHAFT BRG (1 60MM THK)	94107689
	C11	4.376	SHIM, INPUT SHAFT BRG (1 68MM THK)	94107690
	C11	4.376	SHIM, INPUT SHAFT BRG (1 76MM THK)	94107691
	C11	4.376	SHIM, INPUT SHAFT BRG (1 84MM THK)	94107692
	C11	4.376	SHIM, INPUT SHAFT BRG (1 92MM THK)	94107693
	C11	4.376	SHIM, INPUT SHAFT BRG (2 00MM THK)	94107694
	C11	4.376	SHIM, INPUT SHAFT BRG (2 08MM THK)	94107695
	C11	4.376	SHIM, INPUT SHAFT BRG (2 16MM THK)	94107696
	C11	4.376	SHIM, INPUT SHAFT BRG (2 24MM THK)	94107697
	C11	4.376	SHIM, INPUT SHAFT BRG (2 32MM THK)	94107698
	C11	4.376	SHIM, INPUT SHAFT BRG (2 40MM THK)	94107699
	C11	4.376	SHIM, INPUT SHAFT BRG (2 48MM THK)	94107700
50.	C11	4.416	SHIM, OUTPUT SHAFT BRG (2 44MM THK)	94249544
	C11	4.416	SHIM, OUTPUT SHAFT BRG (2 36MM THK)	94249545
	C11	4.416	SHIM, OUTPUT SHAFT BRG (2 28MM THK)	94249546
	C11	4.416	SHIM, OUTPUT SHAFT BRG (2 20MM THK)	94249547

50.	C11	4.416	SHIM, OUTPUT SHAFT BRG (2 12MM THK)	94249848
	C11	4.416	SHIM, OUTPUT SHAFT BRG (2 04MM THK)	94249849
	C11	4.416	SHIM, OUTPUT SHAFT BRG (1 96MM THK)	94249850
	C11	4.416	SHIM, OUTPUT SHAFT BRG (1 88MM THK)	94249851
	C11	4.416	SHIM, OUTPUT SHAFT BRG (1 80MM THK)	94249852
	C11	4.416	SHIM, OUTPUT SHAFT BRG (1 72MM THK)	94249853
	C11	4.416	SHIM, OUTPUT SHAFT BRG (1 64MM THK)	94249854
	C11	4.416	SHIM, OUTPUT SHAFT BRG (1 56MM THK)	94249855
	C11	4.416	SHIM, OUTPUT SHAFT BRG (1 48MM THK)	94249856
	C11	4.416	SHIM, OUTPUT SHAFT BRG (1 40MM THK)	94249857
	C11	4.416	SHIM, OUTPUT SHAFT BRG (1 32MM THK)	94249858
	C11	4.416	SHIM, OUTPUT SHAFT BRG (1 24MM THK)	94249859
	C11	4.416	SHIM, OUTPUT SHAFT BRG (1 16MM THK)	94249860
51.	C11	4.415	WASHER, 5TH GEAR THR	94321335
52.	C11	4.355	BEARING, 5TH NDL	94465413
53.	C11	4.376	COLLAR, 5TH GR NDL BRG	94316287
54.	C11	4.415	GEAR, OUTPUT 5TH	94139578
55.	C11	4.380	SYNCHRONIZER, 5TH GR	94249749
56.		N.S.	SLEEVE, 5TH SYN (PART OF #55)	
57.		N.S.	HUB, 5TH GR CLU (PART OF #55)	
58.	C11	4.384	INSERT, 3RD & 4TH & 5TH GR SYN	94249576
59.	C11	4.384	SPRING, 5TH INSERT	94249577
60.	C11	4.383	RING, 3RD & 4TH & 5TH GR BLOCKING	94249580
61.	C11	4.412	PLATE, INS STOPPER	94249752
62.	C11	4.412	NUT, SLEV & HUB	94124014
63.	C11	4.430	GEAR, REV IDLER	94180849
64.	C11	4.433	SHAFT, REV IDLER	94153350
65.		8.939	PIN, STGHT (4MMX8)	
66.		8.900	BOLT, HEX (MBX1 25X50) 10 9 PC	23049567
67.		8.955	GASKET, COP FLT WA TYPE (M10 2X16X1)	94000373
68.	N13	0.795	SHAFT, CLU FORK	94315475
69.	N13	0.799	BEARING, CLU REL	94133417
70.	N14	0.805	SPRING, REL BRG	94251599
71.	N13	0.799	BEARING, CLU FORK SHF	474665
72.	N14	0.805	SEAL, CLU FORK SHF	14092820
73.	N14	0.859	COVER, CLU PRESS-W/PLT (14091961
74.	N14	0.886	PLATE, CLU DRIVEN	14091962
75.	C11	4.105	PLUG, TORQ STRUT-BRKT HOLE	94043520
76.	N14	0.805	CAP, CLU SHF SEAL	94162203

NOTE 1 1986 1ST DES DOES NOT HAVE A 1/8" AIR GROOVE CAST INTO CASE

NOTE 2 1986 2ND DES HAS A 1/8" AIR GROOVE CAST INTO CASE BETWEEN 3RD/4TH SHIFT ROD & 1ST/2ND SHIFT ROD DETENT BALL AIR HOLES

GM04-320
022288

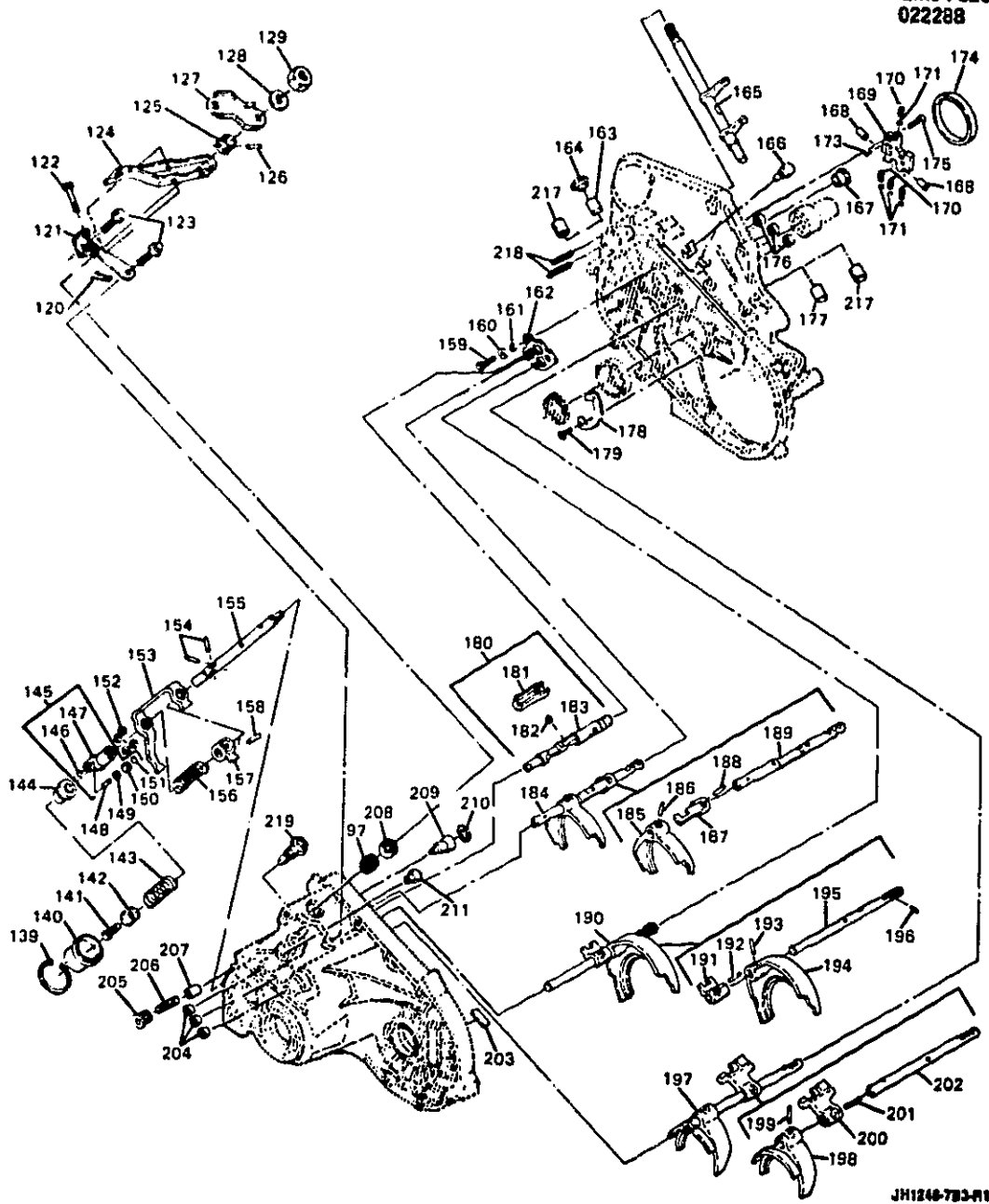

JH12467B3-R1

GM04-320

1986-1988 P 5-SPEED MANUAL TRANSAXLE PART 1 (MG2)(MUNCIE-282)

97.	C11	4.309	BEARING, SHFT SHF NDL	9441638
120.		8.934	RETAINER, TYPE B SPR STL(*1)	10040797
121.	C11	4.046	BRACKET, SEL LVR	10054291
122.		N.S.	PIN, SEL LVR PIV(*1)	
123.		8.900	BOLT, HFH (MBX1 25X20) 10 9 POR	11514343
124.	C11	4.302	LEVER, SELECTOR	10054292
125.	C11	4.037	COLLAR, SEL LVR	14091789
126.		8.939	PIN, SPR (M5X30) TYPE C ZINC(*1)	11513384
127.	C11	4.045	LEVER, EXTERNAL SHFT	10038859
128.	C11	4.045	WASHER, SHFT LVR	14091790
129.		N.S.	NUT, HEX (M14X2X12 5) 10 POR	
139.	C11	4.105	RETAINER, SHFT SHF CVR	14080598
140.	C11	4.309	COVER, SHFT SHF	14080595
141.	C11	4.311	BOLT, HEX (M6X1X16)	14082175
142.	C11	4.311	SEAT, 5TH DETENT OTR SPR	14082047
143.	C11	4.311	SPRING, 5TH DETENT	10051640
144.	C11	4.311	SEAT, 5TH DETENT INR SPR	10051665
145.	C11	4.302	LEVER, DETENT ASM (INCL #146-7-8-9.150-1)	10051630
146.		N.S.	RETAINER, PIN DETENT (PART OF #145)	
147.		N.S.	LEVER, DETENT (PART OF #145)	
148.		N.S.	PIN, DETENT LVR (PART OF #145)	
149.		N.S.	SPACER, DETENT LVR (PART OF #145)	
150.		N.S.	ROLLER, DETENT LVR (PART OF #145)	
151.		N.S.	RETAINER, PIN DETENT (PART OF #145)	
152.	C11	4.311	ROLLER, DETENT	23049899
153.	C11	4.302	LEVER, REV	8672038
154.		N.S.	PIN, DETENT LVR RLR	
155.	C11	4.309	SHAFT, SHFT	14092011
156.	C11	4.311	SPRING, 3RD/4TH BIAS	14082048
157.	C11	4.302	LEVER, SHFT (INTERNAL)	8672298
158.		N.S.	PIN, SHF LVR RET(*1)	
159.	C11	4.307	SCREW, CVR (M6X1X32) 9 8 PL	10051671
160.		8.931	WASHER, LOCK (M8 5X18X3) STL ZN (1 428)	14080586
161.	C11	4.307	SLEEVE, SHFT	14080585
162.	C11	4.307	PLATE, SHFT INTLK	14080584
163.	N13	0.795	BEARING, CLU FORK SHF UPR (24 1MM O D)	14092055
164.	N14	0.805	SEAL, CLU FORK SHF	14092820
165.	N13	0.795	SHAFT, CLU FORK (1986-87)(1988-8ZL)	8672937
	N13	0.795	SHAFT, CLU FORK (1988-8XPX)	8672942
	C11	4.104	VENT, TRANS	10051641
167.	C11	4.309	BUSHING, SHFT RAIL	14080593
168.		N.S.	PIN, INTLK (PART OF #169)	
169.	C11	4.311	HOLDER KIT, DETENT	8672917
170.		N.S.	SPRING, DETENT (PART OF #171)	
171.	C11	4.311	BALL, DETENT-W/SPR	8672923
173.		N.S.	PIN, SPR (PART OF #169)	
174.	C11	4.311	COVER, DETENT HOLDER	14092039
175.	C11	4.307	SCREW, HEX SCKT HD (M6X1X32) 9.8 PL	10051671
176.	C11	4.309	BEARING, SHFT RAIL(1-2,3-4,5)	14080583
	C11	4.309	BEARING, SHFT RAIL(REV)	14080571
177.	N13	0.795	BEARING, CLU FORK SHF LWR (20.0MM O D)(PART OF #165)	14092054
178.	C11	4.355	RETAINER, CLU HSG OUTPUT BRG	14092032
179.		8.900	BOLT, HEX (M6X1X13) 9.8 POR	10042901
180.		N.S.	RAIL, ASM REV SHFT (INCLUDES #181-2-3)	14092012
181.	C11	4.302	GATE, 5TH/REV SHFT	14092078
182.	C11	4.312	ROLLER, GR DISENGAGE	14092090
183.	C11	4.309	RAIL, REV SHFT	14092076
184.	C11	4.309	RAIL ASM, 3RD/4TH SHFT (INCL #185-6-7-8-9)	10051632
185.		N.S.	FORK, 3RD/4TH SHFT (PART OF #184)	
186.		N.S.	PIN, FORK RET (PART OF #184)	
187.		N.S.	LEVER, 3RD/4TH SEL (PART OF #184)	
188.		N.S.	PIN, LVR RET (PART OF #184)	
189.		N.S.	SHAFT, 3RD/4TH SHFT (PART OF #184)	
190.	C11	4.309	RAIL ASM, 1ST/2ND SHFT (INCL #191-2-3-4-5-6)	10051631
191.		N.S.	LEVER, 1ST/2ND SEL (PART OF #190)	
192.		N.S.	PIN, LVR RET (PART OF #190)	
193.		N.S.	PIN, FORK RET (PART OF #190)	
194.		N.S.	FORK, 1ST/2ND SHFT (PART OF #190)	
195.		N.S.	SHAFT, 1ST/2ND SHFT (PART OF #190)	
196.	C11	4.307	PIN, INTLK (M3.9X13.6)	14092017
197.	C11	4.309	RAIL ASM, 5TH SHFT (INCL #198-9.200-1-2)	14092083
198.		N.S.	FORK, 5TH SHFT (PART OF #197)	
199.		N.S.	PIN, FORK RET (PART OF #197)	

200.	N.S.	LEVER, 5TH SHFT (PART OF #197)	
201.	N.S.	PIN, LVR RET (PART OF #197)	
202.	N.S.	SHAFT, 5TH SHFT (PART OF #197)	
203. C11	4.105	MAGNET, CHIP COLLECTOR	465474
204.	8.970	PLUG, CUP (17ODX1 THX5 DEEP) STL	14080573
205. C11	4.307	SCREW, SLDG SLEV SPR	14082165
206. C11	4.307	SPRING, SLDG SLEV	14082041
207. C11	4.307	SLEEVE, SLDG	14082040
208. C11	4.309	SEAL, SHF SHFT("1)	14080587
209. C11	4.104	PLUG,	14082193
210.	N.S.	RING, RET	
211.	N.S.	PLUG, TRANS FILL(SHIPPING PURPOSES ONLY)	
217. N13	0.795	BEARING, CLU FORK SHF LWR(BUSHING TYPE)(1986-87)(1988-8ZL)	14092054
N13	0.795	BEARING, CLU FORK SHF LWR(NEEDLE ROLLER)(1988-8XPX)	23047095
N13	0.795	BEARING, CLU FORK SHF UPR (24 1MM O D)	14092055
218.	.	STUD, CLU CYL (NOT USED ON P CAR)	
219. N22	2.698	SWITCH, BACK UP LP	10075403

NOTE 1 PART OF 4 005 8672918 - OVERHAUL KIT

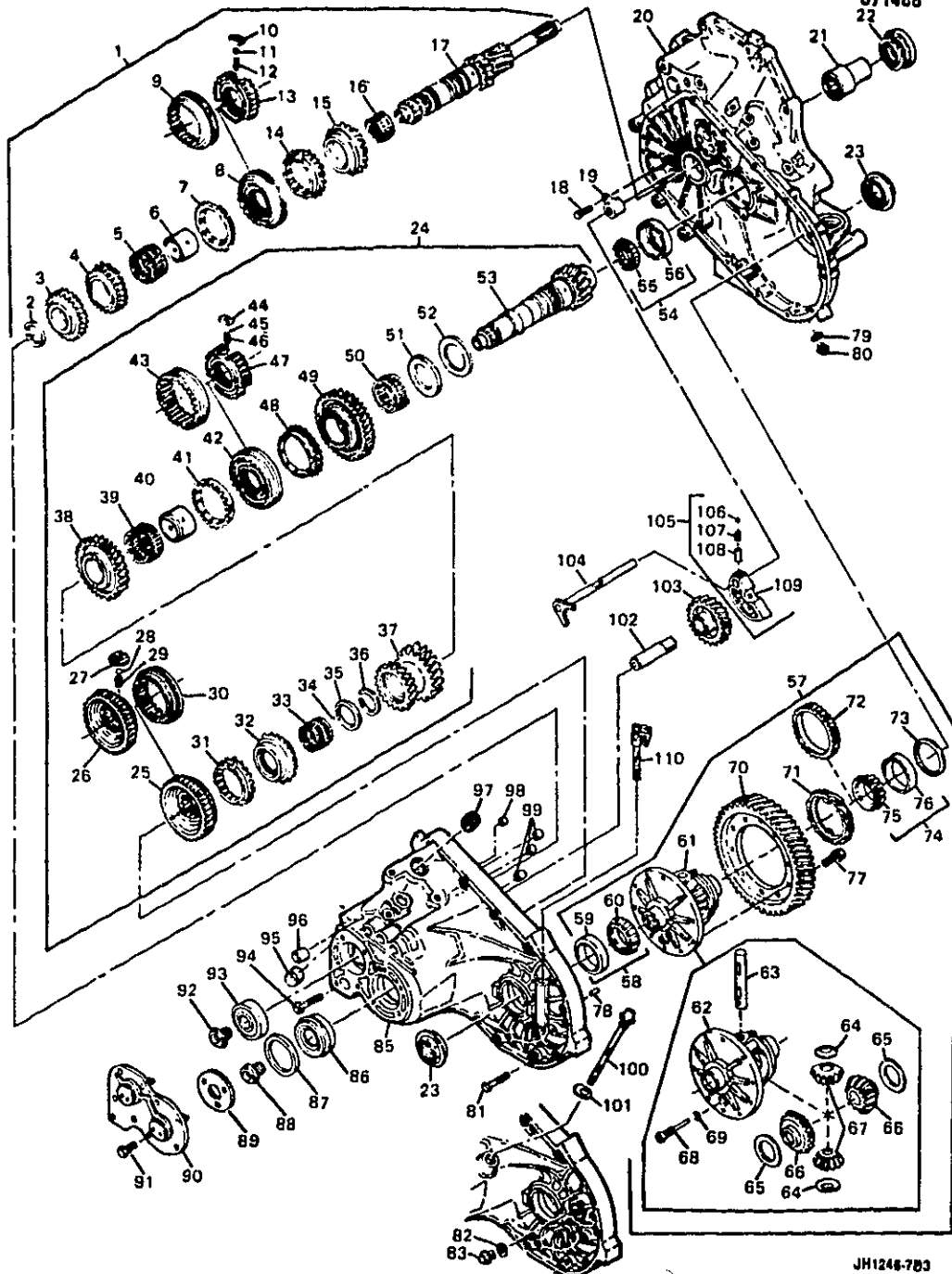

JH1244-783

GM04-284

1986-1988 P 5-SPEED MANUAL TRANSAXLE PART 2 (MG2)(MUNCIE-282)

1.	N.S.	SHAFT, INPUT-W/GR (SERVICED BY COMPONENTS #2 THRU #17)	
2.	C11	4.356 SNAP RING, SHF (1.7 THK)(*1)	10051684
3.	C11	4.415 GEAR, 5TH SPD INPUT	10051618
4.	C11	4.415 GEAR, 4TH SPD INPUT (1986-87)	10051621

4.	C11	4.415	GEAR, 4TH SPD INPUT (1988 89)	23047418
5.	C11	4.416	BEARING, 4TH GR	9441542
6.	C11	4.355	RACE, 4TH GR BRG (1986-87)	14082121
	C11	4.355	RACE, 4TH GR BRG (1988-89)	23047421
7.	C11	4.383	RING, 4TH GR BLOCKING	8672051
8.	C11	4.380	SYNCHRONIZER, 3RD-4TH GR (INCL #9.13)	10051607
9.		N.S.	SLEEVE, 3-4 SYN (PART OF #1.8)	
10.	C11	4.384	KEY, 3-4 SYN	14092094
11.		N.S.	BALL, 3-4 SYN(*1)	
12.		N.S.	SPRING, 3-4 SYN(*1)	
13.		N.S.	HUB, 3-4 GR SYN (PART OF #8)	
14.	C11	4.383	RING, 3RD GR BLOCKING	8672051
15.	C11	4.415	GEAR, 3RD SPD INPUT (1986-87)	10051614
	C11	4.415	GEAR, 3RD SPD INPUT (1988-89)	23047416
16.	C11	4.383	BEARING, 3RD GR	9441541
17.	C11	4.351	GEAR, INPUT CSTR (1986-87)	14092085
	C11	4.351	GEAR, INPUT CSTR (1988-89)	8672955
18.		8.900	BOLT, HEX (M6X1X25) 10 9 PS	11509417
		8.800	ADHESIVE KIT, THREAD LOCK 10 ML	12345493
19.	C11	4.309	GUIDE, REV SHFT RAIL	23047801
20.	N13	0.683	HOUSING, CLU & DIFF (1986-87)(1988-8ZP.ZM.ZN.ZL)	8672901
	N13	0.683	HOUSING, CLU & DIFF (1988-8XKX.XLX.XNX.XPX)	8672939
	N13	0.683	HOUSING, CLU & DIFF (1989)	8672939
21.	C11	4.355	BEARING, INPUT SHF-W/SLEV	14082181
22.	N13	0.799	BEARING, CLU REL	14080591
23.		6.081	SEAL, DRIVE SHF OIL	90342143
24.		N.S.	SHAFT, OUTPUT CSTR-W/GRS	
25.	C11	4.380	SYNCHRONIZER, REV OUTPUT/5TH GR	14082091
26.		N.S.	GEAR, REV (PART OF #25)	
27.	C11	4.384	KEY, 5TH SYN (3 USED)	14082094
28.		N.S.	BALL, 5TH SYN (PART OF #25)	
29.		N.S.	SPRING, 5 SYN (PART OF #25)	
30.		N.S.	SLEEVE, 5TH SYN (PART OF #25)	
31.	C11	4.383	RING, 5TH GR BLOCKING	8672051
32.	C11	4.415	GEAR, 5TH SPD OUTPUT	10051620
33.	C11	4.416	BEARING, 5TH GR	9441543
34.		N.S.	BALL, THR WA POSITIONER (PART OF #36)(*1)	
35.		N.S.	WASHER, THR (PART OF #36)	
36.	C11	4.384	RING KIT, W/BALL & WA (INCL #34.35)	8672914
37.	C11	4.415	GEAR, 3RD/4TH CSTR (1986-87)	10051619
	C11	4.415	GEAR, 3RD-4TH OUTPUT (1988-89)	8672185
38.	C11	4.395	GEAR, 2ND OUTPUT (1986-87)	10051616
	C11	4.395	GEAR, 2ND SPD OUTPUT (1988-89)	23047414
39.	C11	4.383	BEARING, 2ND OUTPUT	9441540
40.	C11	4.355	RACE, 2ND GR BRG (1986-87)	14080545
	C11	4.355	RACE, 2ND GR BRG (1988-89)	23047420
41.	C11	4.383	RING, 2ND GR BLOCKING	8672049
42.	C11	4.380	SYNCHRONIZER, 1ST/2ND GR (INCL #43 THRU 47)	23047862
43.		N.S.	SLEEVE, 1-2 SYN (PART OF #42)	
44.		N.S.	KEY, 1ST/2ND SYN (3 USED)(PART OF #42)	
45.		N.S.	BALL, 1ST/2ND SYN (PART OF #42)	
46.		N.S.	SPRING, 1-2 SYN (PART OF #42)	
47.		N.S.	HUB, 1-2 SYN (PART OF #42)	
48.	C11	4.383	RING, 1ST GR BLOCKING	8672049
49.	C11	4.417	GEAR, 1ST SPD OUTPUT (1986-87)	14092095
	C11	4.417	GEAR, 1ST SPD OUTPUT (1988-89)	23047412
50.	C11	4.383	BEARING, 1ST OUTPUT	9441539
51.	C11	4.355	BEARING, THR	10051633
52.	C11	4.355	RACE, THR BRG	10051634
53.	C11	4.421	GEAR, OUTPUT (1986-87)	14082129
	C11	4.421	SHAFT, W/OUTPUT GR (1988-89)	8672184
54.	C11	4.422	BEARING, OUTPUT GR FRT (INCL #55.56)	14092035
55.		N.S.	BEARING, OUTPUT (PART OF #54)	
56.		N.S.	RACE, BRG OUTPUT (PART OF #54)	
57.		N.S.	DIFFERENTIAL, W/GR	
58.	E14	5.538	BEARING, DIFF SI (INCL 59.60)	9437733
59.		N.S.	CUP, DIFF BRG (PART OF #58)	
60.		N.S.	TAPER CONE, DIFF BRG (PART OF #58)	
61.	E13	5.510	DIFFERENTIAL (INCL #62 THRU 69)	8672381
62.		N.S.	CASE, DIFF (PART OF #61)	
63.	E13	5.517	SHAFT, DIFF PIN (PART OF #61)(*1)	463082
64.	E15	5.542	WASHER, DIFF PIN THR (PART OF #61)(*1)	463081
65.	E15	5.543	WASHER, DIFF SI GR THR (PART OF #61)(*1)	14040531
66.	E14	5.528	GEAR, DIFF SI (PART OF #61)(*1)	14076988
67.		N.S.	GEAR, DIFF PIN (PART OF #61)(*1)	

68.	E13	5.518	SCREW, DIFF PIN SHF (PART OF #61)	463063
69.		8.931	WASHER, LOCK (PART OF #61)	9439511
70.	E14	5.529	GEAR, DIFF RG	14082130
71.	C11	4.343	GEAR, SPEEDO DRIVE (35 T)(NAT)(1986)	
	C11	4.343	GEAR, SPEEDO DRIVE (35 T)(NAT)(1987-ZNH.XCX)	
	C11	4.343	GEAR, SPEEDO DRIVE (35 T)(NAT)(1988-8ZL.ZM.XPX.XLX)	
	C11	4.343	GEAR, SPEEDO DRIVE (35 T)(NAT)(1989-9XLX)	
72.		4.329	ROTOR, SPEED SENSOR (34T)(1987-DAN)	
		4.329	ROTOR, SPEED SENSOR (34T)(1988-8ZP.ZZH.XHX)	
		4.329	ROTOR, SPEED SENSOR (28T)(1987-XBX)	
		4.329	ROTOR, SPEED SENSOR (28T)(1988-8ZN.ZZJ.XNX)	
		4.329	ROTOR, SPEED SENSOR (29T)(1989-9XNX)	
73.	E13	5.508	SHIM KIT, DIFF HSG BRG (0.30-0.70)	8672903
	E13	5.508	SHIM KIT, DIFF HSG BRG (0.60-1.00)	8672904
	E13	5.508	SHIM KIT, DIFF HSG BRG (0.90-1.30)	8672905
74.	E14	5.536	BEARING, DIFF SI (INCL #75.76)	9437733
75.		N.S.	BEARING, DIFF SI (PART OF #74)	
76.		N.S.	RACE, DIFF SI BRG (PART OF #74)	
77.	E14	5.531	BOLT, DIFF RG GR (10 USED)	14080521
78.	C11	4.104	PIN, TRANS CASE LOC	360570
79.	C11	4.195	WASHER, DRN SCR	476756
80.	C11	4.105	SCREW, DRN (M14 X1.5X14.5)	14056604
81.		8.900	BOLT, HEX (M8X1.25X50) 10.9 PC	23049567
82.	C11	4.105	WASHER, FIL PLUG	476753
83.	C11	4.105	PLUG, FIL (M20X1.5)	476753
85.	C11	4.103	CASE, TRANS (INCL #23.58.82.83.95.98.101.203)	8672928
86.	C11	4.422	BEARING, OUTPUT GR RR(*1)	23047493
87.	C11	4.422	SHIM KIT, OUTPUT GR	8672919
88.	C11	4.355	RETAINER, OUTPUT GR BRG(*1)	14092025
89.		6.058	WASHER, OIL SLINGER (1987-88)	10051857
90.	C11	4.103	PLATE, CASE END (1986-87)	23047422
	C11	4.103	PLATE, CASE END (1988-89)	23047422
91.	C11	4.105	SCREW, CASE END PLATE (9 USED)	10051837
92.	C11	4.358	RETAINER, INPUT GR BRG(*1)	14092024
93.	C11	4.355	BEARING, INPUT GR(*1)	14092068
94.			BOLT, REV IDLER (M8X1.25)	
95.	C11	4.302	BUSHING, DETENT LVR	14092005
96.	N13	0.799	BUSHING, SLIDING SLEV	14080570
97.	C11	4.408	BEARING, SHFT SHF NDL	9441538
98.	C11	4.309	BEARING, REV SHFT RAIL	14080571
99.		8.970	PLUG, SHFT RAIL	14080573
100.	C11	4.346	INDICATOR, OIL LVL	22540197
101.	C11	4.346	WASHER, FLUID LVL INDICATOR (1987)	14080243
	C11	4.346	WASHER, FLUID LVL INDICATOR (1988-89)	
102.	C11	4.433	SHAFT, REV IDLER	14080538
103.	C11	4.430	GEAR, REV IDLER	14080558
104.	C11	4.309	RAIL, REV SHFT IDLER GR	14082012
105.	C11	4.435	BRACKET, REV IDLER (INCL #108.9)	23047852
106.	C11	4.311	BALL, DETENT-W/SPR (INCL #107)	8672923
107.		N.S.	SPRING, DETENT (PART OF #106)	
108.		N.S.	SLEEVE, REV IDL GR DETENT BRKT (PART OF #105)	
109.		N.S.	BRACKET, REV IDLER (PART OF #105)	
110.	C11	4.346	INDICATOR, OIL LVL	22540197

NOTE 1. PART OF 4.005 8672918 - OVERHAUL KIT

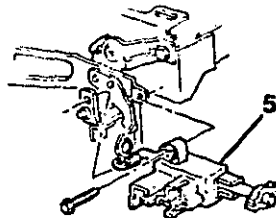
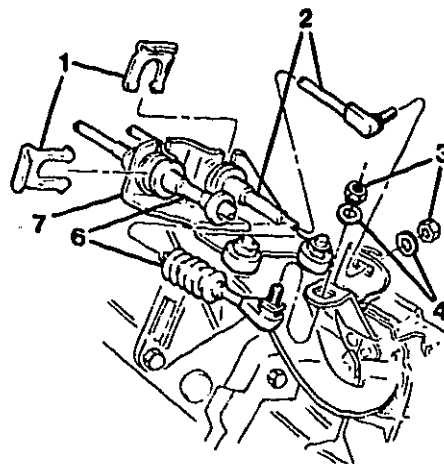
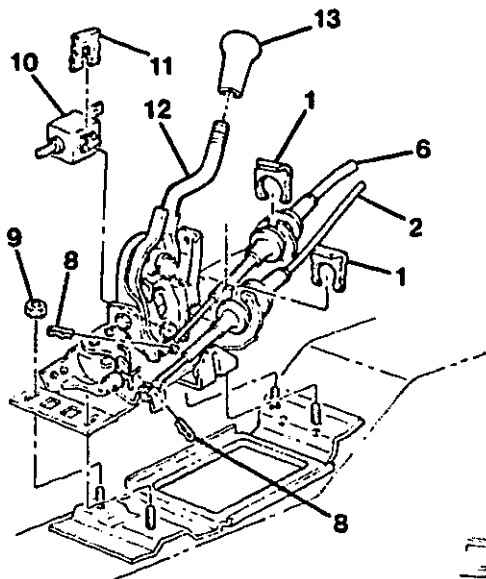

2P04-007

1984-1985 P SHIFT CONTROLS/MANUAL TRANSMISSION FLOOR

1.	C11	4.047	RETAINER, CBL	12338095
2.	C11	4.047	CABLE, TRANS SEL LVR (1984)	10026826
	C11	4.047	CABLE, TRANS SEL LVR (1985)	
3.		8.915	NUT, HEX (M10 X 1.5)	
4.		8.929	WASHER, FLAT (10MM)	
5.	C11	4.054	SWITCH, TRANS CLU START (1984)	10045862
	C11	4.054	SWITCH, TRANS CLU START (1985)	
		8.977	SCREW, (M4.2X1.41X30) HWH DR & TAP	
6.	C11	4.047	CABLE, TRANS SHFT LVR (1984)	10028819
	C11	4.047	CABLE, TRANS SHFT LVR (1985)	
	C11	4.008	GROMMET, TRANS CONT CBL	10017820
	C11	4.047	STUD, TRANS CONT CBL LVR	14091788
7.		4.017	BRACKET, TRANS CONT SHFT CBL	10035022
8.	C11	4.047	RETAINER, TRANS CONT CABLE (1/4" SPRING RET)	9791386
9.		8.917	NUT, HFH (M8 X 1.25)	
10.	N22	2.898	SWITCH, B/U LP	14009262
11.		N.S.	RETAINER, B/U LP SW	
12.	C11	4.004	CONTROL, TRANS	10038097
13.	C11	4.006	KNOB, CONT LVR (MEDDOESKIN)	10031075

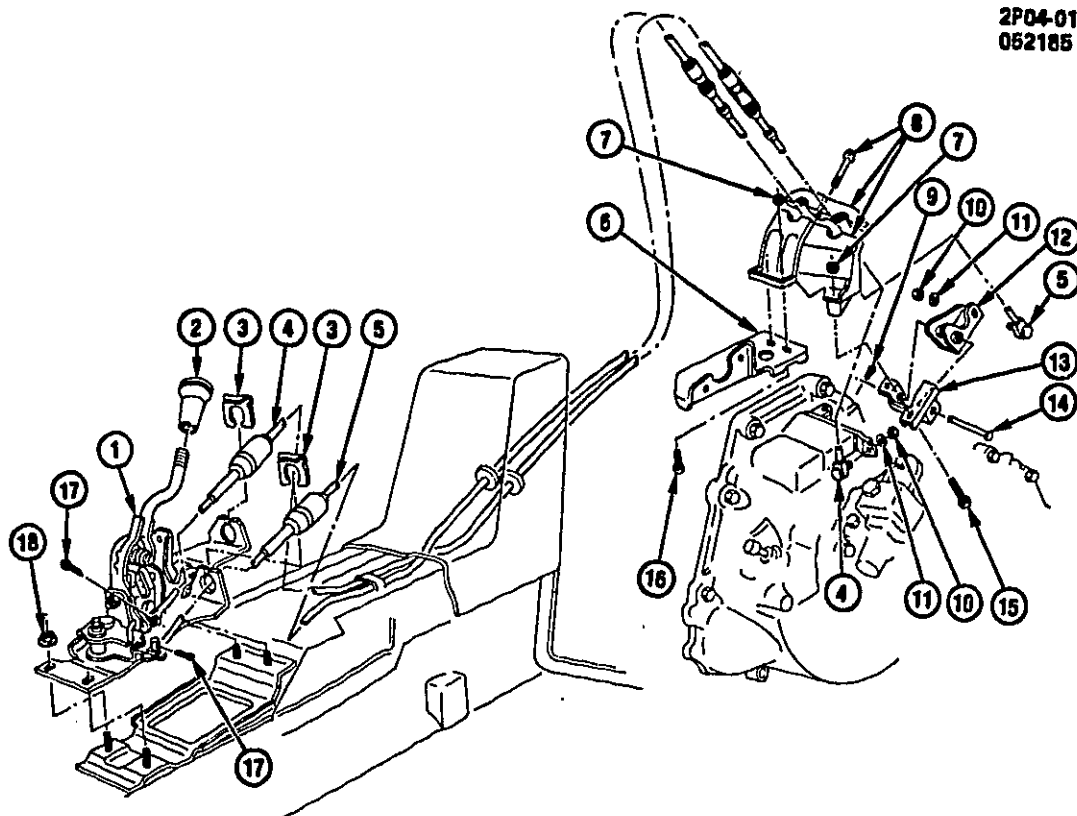

2P04-010

1985-1988 P SHIFT CONTROLS/MANUAL TRANSMISSION FLOOR (MT2)

1.	C11	4.004	CONTROL, TRANS	10042357
2.	C11	4.008	KNOB, TRANS CONT LVR (MED DOESKIN)(1985 EXC NP5)	10031075
	C11	4.008	KNOB, TRANS CONT LVR (GRAPHITE VINYL)(1985-88 EXC NP5)	10031076
	C11	4.008	KNOB, TRANS CONT LVR (SIENNA)(W/NP5)(1988)	10111548
	C11	4.008	KNOB, TRANS CONT LVR (DK SIENNA)(EXC NP5)(1988)	10078180
	C11	4.008	KNOB, TRANS CONT LVR (GRAPHITE LEATHER)(W/NP5)(1985-88)	14105748
3.	C11	4.047	RETAINER, TRANS CONT LVR CBL	12338095
	C11	4.047	RETAINER, RANGE SEL LVR CBL TO MTG BRK (1986-88)	12338095
4.	C11	4.047	CABLE, TRANS SHFT LVR	14105817
5.	C11	4.047	CABLE, TRANS SEL LVR	14105818
6.	C11	4.047	BRACKET, TRANS SEL SHFT LVR CBL BRKT (2.5R)	10037898
7.		8.917	NUT, HEX TORQ PREV (M8X1.25) 10 CAD	
8.	C11	4.047	BRACKET, TRANS SEL SHFT LVR CBL (1985-86)	10038294
	C11	4.047	BRACKET, TRANS SEL SHFT LVR CBL (1987-88)	10037898
9.		8.934	RETAINER, TYPE B (.062 SPRING STEEL WIR)	
10.		8.915	NUT, HEX (M10X1.5X9)	
11.		8.929	WASHER, FL (13/32"X13/16"X1/16")	
12.	C11	4.045	LEVER, TRANS SEL (2.5R)	10086490
13.	C11	4.047	BRACKET, TRANS SEL LVR (2.5R)	10034203
14.	C11	4.008	PIN, TRANS SEL LVR PIV (2.5R)	477095
15.	C11	4.027	STUD, NEU POSN SET (1985-86)	94149883
		8.900	BOLT, HFH (MBX1.25X25X21.8 THD LEN X18 OD) 10.9 POR (1987)	11509843
16.		8.900	BOLT, HFH (MBX1.25X25) 10.9 PC	11509511
17.	C11	4.047	RETAINER, TRANS CONT CABLE (1/4" SPRING RET)	9791366
18.		8.917	NUT, HEX FLG (M8X1.25)	11507036

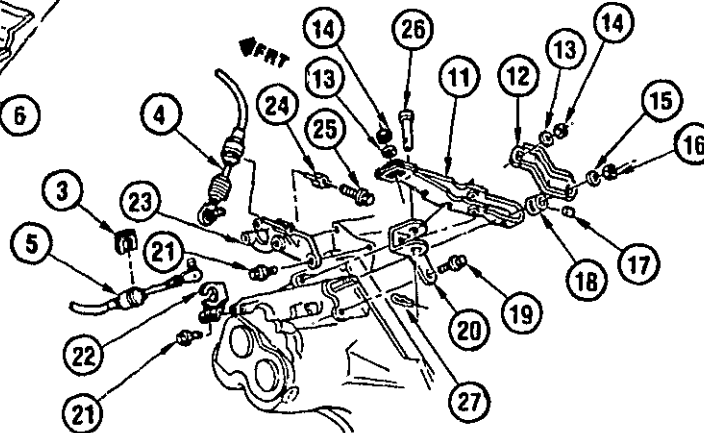
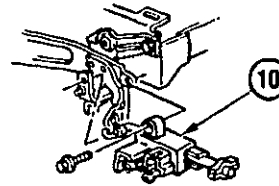
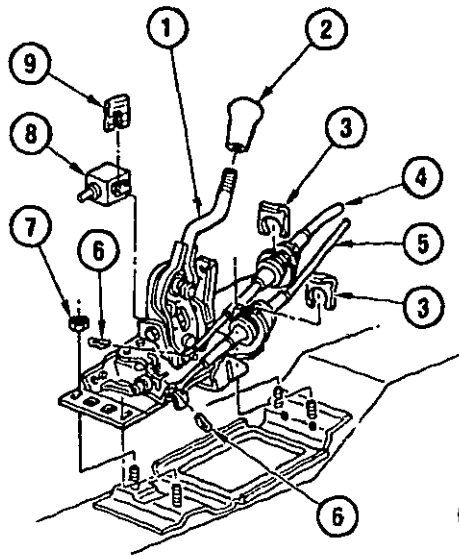

2P04-013

1987 P SHIFT CONTROLS/MANUAL TRANSMISSION FLOOR (MG2)

1.	C11	4.004	CONTROL, TRANS	14105798
2.	C11	4.006	KNOB, TRANS CONT LVR (GRAPHITE VINYL)	10031076
3.	C11	4.047	RETAINER, TRANS CONT LVR CBL	12338095
4.	C11	4.047	CABLE, TRANS SHFT LVR	10068448
5.	C11	4.047	CABLE, TRANS SEL LVR	10054258
6.	C11	4.047	RETAINER, TRANS CONT CABLE (1/4" SPRING RET)	9791366
7.		8.917	NUT, HFH (M8-1.25)	
8.	N22	2.698	SWITCH, B/U LP	14009262
9.		N.S.	RETAINER, B/U LP SW	
10.	C11	4.054	SWITCH, TRANS CLU START	10045862
11.	C11	4.302	LEVER, CONT SEL	10054292
12.	C11	4.046	LEVER, SHIFT (EXTERNAL)	10038669
13.		8.929	WASHER, FL (M11X20X2)	
14.		8.915	NUT, HEX (M10X1.5X9)	
15.	C11	4.046	WASHER, SHIFT LEVER	14091790
16.		8.900	NUT, HEX (M14X2X12.5)	
17.		8.939	PIN, COILED SPRING-TYPE C (M5 2X25)	
18.	C11	4.037	COLLAR, SEL LVR	14091789
19.		8.900	BOLT, HFH (M8X1.25X20) 10.9 POR	11514343
20.	C11	4.046	BRACKET, SEL LVR	10054291
21.		8.900	BOLT, HFH (M8X1.25X20) 10.9 POR	11514343
22.		N.S.	BRACKET, TRANS SEL LVR CBL	
23.		N.S.	BRACKET, SHFT LVR CBL	
24.	C11	4.047	RETAINER, TRANS SHFT LVR CBL	
25.		8.900	BOLT, HEX (M8X1.25X40 10.9 PC)	
26.	C11	4.008	PIN, CONT SEL LVR BRKT	477095
27.		8.934	RETAINER, TYPE B (062 SPRING STEEL WIR)	

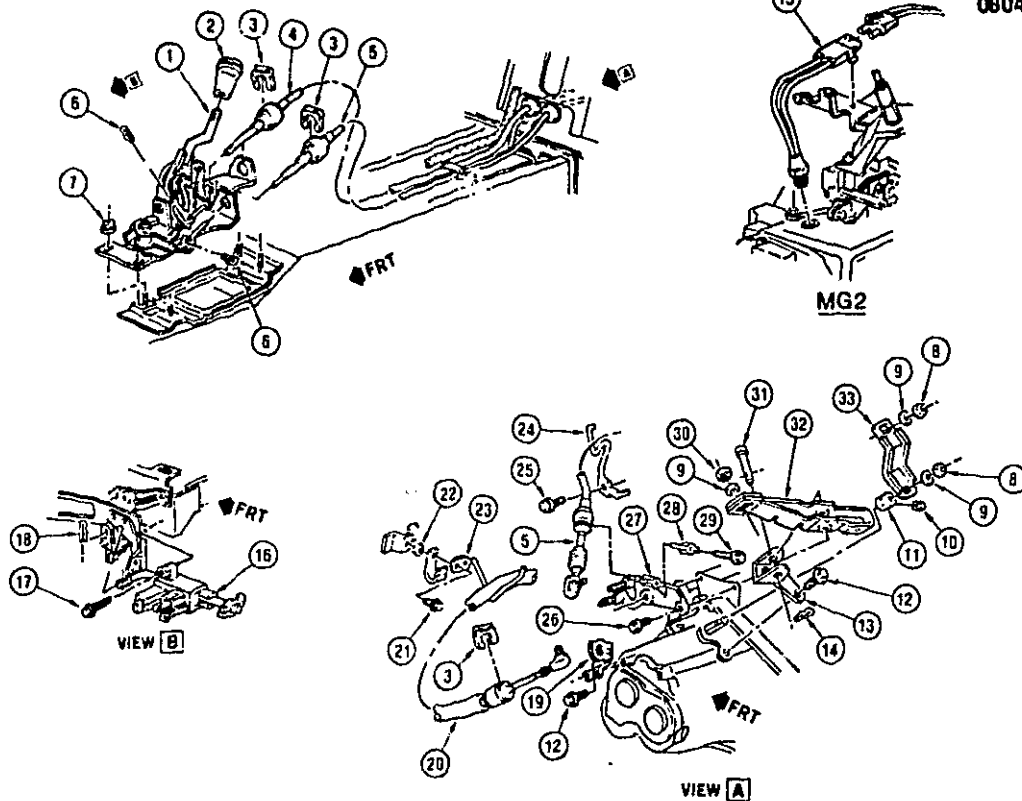

2P04-016

1988 P SHIFT CONTROLS/MANUAL TRANSMISSION FLOOR (MG2)

1	C11	4.004	CONTROL, TRANS	14105796
2	C11	4.008	KNOB, TRANS CONT LVR (GRAPHITE VINYL)	10031076
3	C11	4.047	RETAINER, TRANS CONT CABLE (1/4" SPRING RET)	9791366
4	C11	4.047	CABLE, TRANS SHFT LVR	10088448
5	C11	4.047	CABLE, TRANS SHFT LVR	10088448
6	C11	4.047	RETAINER, TRANS CONT LVR CBL	12338095
7		8.917	NUT, HFH (M8X1.25X7.50)10 PEOR	11507036
8		8.921	RETAINER, PUSH ON TYPE "E"	9428633
9		8.929	WASHER, FL (M11X20X2)1050 HARD CAD	25517558
10		8.939	PIN, COILED SPRING-TYPE "C" (M5 2X25)	
11	C11	4.037	COLLAR, SEL LVR	14091789
12		8.900	BOLT, HFH (M8X1 25X20) 10 9 POR	11514343
13	C11	4.048	BRACKET, SEL LVR	10054291
14		8.934	RETAINER, TYPE "B" (.062 SPRING STEEL WIRE)	
15	N22	2.698	SWITCH, B/U LP (BLA)	10075403
16	C11	4.054	SWITCH, TRANS NEU START	10045862
17		8.977	SCREW, HWH (M4.2X1.41X30)6172M PZOR	11508602
18		8.934	SPRING, CLIP ASH TRAY DOOR	149505
19	C11	4.047	BRACKET, TRANS SEL LVR CBL	10054281
20	C11	4.047	CABLE, TRANS SEL LVR	10054258
21		8.977	BOLT, HEX W/FL WA (M6 3X1.81X20)6010M PZOR	22527475
22		8.921	NUT, PUSH-ON (M6X1)SPR STL(STYLE 1)POR	14093869
23		N.S.	SUPPORT, TRANS SEL LVR CBL/TO TRANS/	
24	C11	4.010	SUPPORT, TRANS SEL SHFT LVR CBL/TO ENG	10037615
25		8.900	SCREW, HEX (M10X1 5X16)9 8 ZC	11513783
26		8.900	BOLT, HFH (M10X1 5X30)	1635490
27	C11	4.047	BRACKET, SHFT LVR CBL	10040978
28	C11	4.047	RETAINER, TRANS SHF LVR CBL	
29		8.900	BOLT, HEX (M8X1.25X40)10.9 PC	
30		8.915	NUT, HEX (M10X1.5X9)10 CD	11505057
31	C11	4.008	PIN, CONT SEL LVR BRKT	477095
32	C11	4.302	LEVER, CONT SEL	10054292
33	C11	4.045	LEVER, SHIFT (EXTERNAL)	10038889

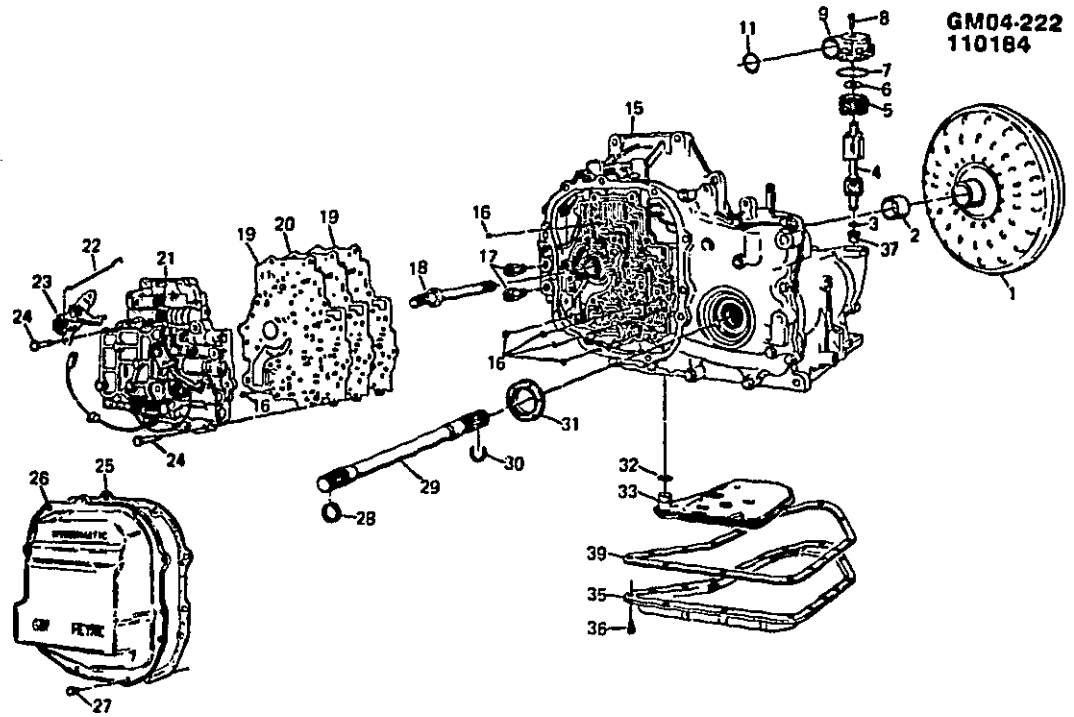

GM04-2223

1984-1988 P AUTOMATIC P (MD9) THM125C CASE & RELATED PARTS

1.	C11	4.115	CONVERTER, TRANS (REMFDX)1984-4PF-5PFX1985-5PFX1986-6PFX1987-7PSC)	8664909
	C11	4.115	CONVERTER, TRANS (REMFDX)1985-5CDX(1986-6CD)	8653954
	C11	4.115	CONVERTER, TRANS (REMFDX)1986-6CPX(1987-7CPC)	8664904
	C11	4.115	CONVERTER, TRANS (REMFDX)1988-8CPC)	8664904
	C11	4.115	CONVERTER, TRANS (REMFDX)1988-8PSC)	8664909
2.		N.S.	BUSHING, CONVR PUMP (PART OF #1)	
3.	C11	4.256	RING, GOV OIL SEAL	8632588
4.	C11	4.256	GOVERNOR, W/SEAL (1985-5CDX)1986-6CD)	8653922
	C11	4.256	GOVERNOR, W/SEAL (1984-4PF-5PFX)1985-5PFX(1986-6PF)	8653920
	C11	4.256	GOVERNOR, W/SEAL (1986-6CPX)1987-7CPCX(1988-8CPC)	8652917
	C11	4.256	GOVERNOR, W/SEAL (1987-7PSCX)1988-8PSC)	8643992
5.	C11	4.343	GEAR, SPEEDO DR (10 TEETH - GRN)	8632646
6.	C11	4.330	WASHER, SPEEDO DR GR THR (1984)	8631766
	C11	4.330	BEARING, SPEEDO DR GR TO CVR(1984-88)(PART OF #9)	8635490
7.	C11	4.256	SEAL, GOV CVR O RING	8649382
8.		8.900	BOLT, HEX (M6X1X25) 10.9 PS	11509417
9.	C11	4.256	COVER KIT, GOV-W/SEALS (INCL #6.7)	9652919
11.	C11	4.338	SEAL, O-RING	8622076
15.	C11	4.103	CASE, TRANS (COMPL)	8653918
16.		8.899	BALL (6.3MM)(6.3 MM)	104918
17.	C11	4.128	CONNECTOR, OIL CLR PIPES TO CASE	8637742
18.	C11	4.226	SHAFT, PUMP DR-W/SPCR (1984)(#1)	8643627
	C11	4.226	SHAFT, PUMP DR-W/SPCR (1984)(#4)(1985-88)	8643784
19.	C11	4.265	GASKET, VLV BDY SPCR PLT (PART OF #20)	8652506
20.	C11	4.265	SPACER, VLV BDY TO CASE CVR (1984-4PF)	8643497
	C11	4.265	SPACER, VLV BODY TO CASE CVR (1984-5PF)	8660566
	C11	4.265	SPACER, VLV BDY TO CASE CVR (1985-5CD)	8660569
	C11	4.265	SPACER, VLV BDY TO CASE CVR (1986-6CD)	8660561
	C11	4.265	SPACER, VLV BDY TO CASE CVR (1986-6PF)	8660723
	C11	4.265	SPACER, VLV BODY TO CASE CVR (1986-6CP)	8660723
	C11	4.265	SPACER, VLV BODY TO CASE CVR (1987-7CP)	8664173
	C11	4.265	SPACER, VLV BODY TO CASE CVR (1987-7PS)	8664787
	C11	4.265	SPACER, VLV BODY TO CASE CVR (1988-8CP)	8652186
21.	C11	4.224	PUMP, W/CONT VLV (1984-4PF)	8652314
	C11	4.224	PUMP, W/CONT VLV (1984/85-5PF)	8652883
	C11	4.224	PUMP, W/CONT VLV (1985-5CD)	8652314
	C11	4.224	PUMP, W/CONT VLV (1986-6PF)	8660489
	C11	4.224	PUMP, W/CONT VLV (1986-6CD)	8660764
	C11	4.224	PUMP, W/CONT VLV (1986-6CP)	8664101
	C11	4.224	PUMP, W/CONT VLV (1987-7CPC)	8665258
	C11	4.224	PUMP, W/CONT VLV (1987-7PSC)	8664775
	C11	4.224	PUMP, W/CONT VLV (1988-8CPC)	8665310
	C11	4.224	PUMP, W/CONT VLV (1988-8PSC)	8631686
22.	C11	4.275	LINK, THROT LVR TO CBL	8631694
23.	C11	4.275	LEVER, THROT-W/BRKT	11503872
24.		8.900	BOLT, HEX (M6X1X45) 10 9 PL	8660039
25.	C11	4.217	GASKET, VLV BDY CVR	8643575
26.	C11	4.215	COVER, VLV BDY	2069759
27.		8.900	BOLT, W/CON SPR WA (M8X1 25X20) 9 8 ZN	7829495
28.	E12	5.428	RING, JT RET (6 061)	8631640
29.	C11	4.175	SHAFT, OUTPUT	8631948
30.	C11	4.005	RING KIT, SNAP TURB SHF TO DR SPKT	8631156
31.		8.061	SEAL, AXLE OIL	1363951
32.	C11	4.197	SEAL, STNR TO CASE O-RING(*3)	8652898
	C11	4.197	SEAL, STNR TO CASE(*4)	8652910
33.	C11	4.197	STRAINER, OIL-W/GSKT	8643574
35.	C11	4.195	PAN, TRANS OIL	
36.		8.900	BOLT, HWH (M8X1 25X16)	
37.	C11	4.256	SLEEVE, GOV SHF	8631328
39.	C11	4.196	GASKET, OIL PAN	8660038

NOTE 1 1ST DES USED WITH 2 PIECE PUMP SHF BRG & SEAL

NOTE 3 USE WITH 9631951 STRAINER

NOTE 4 MULTILIP SEAL USE WITH 8652910 STRAINER

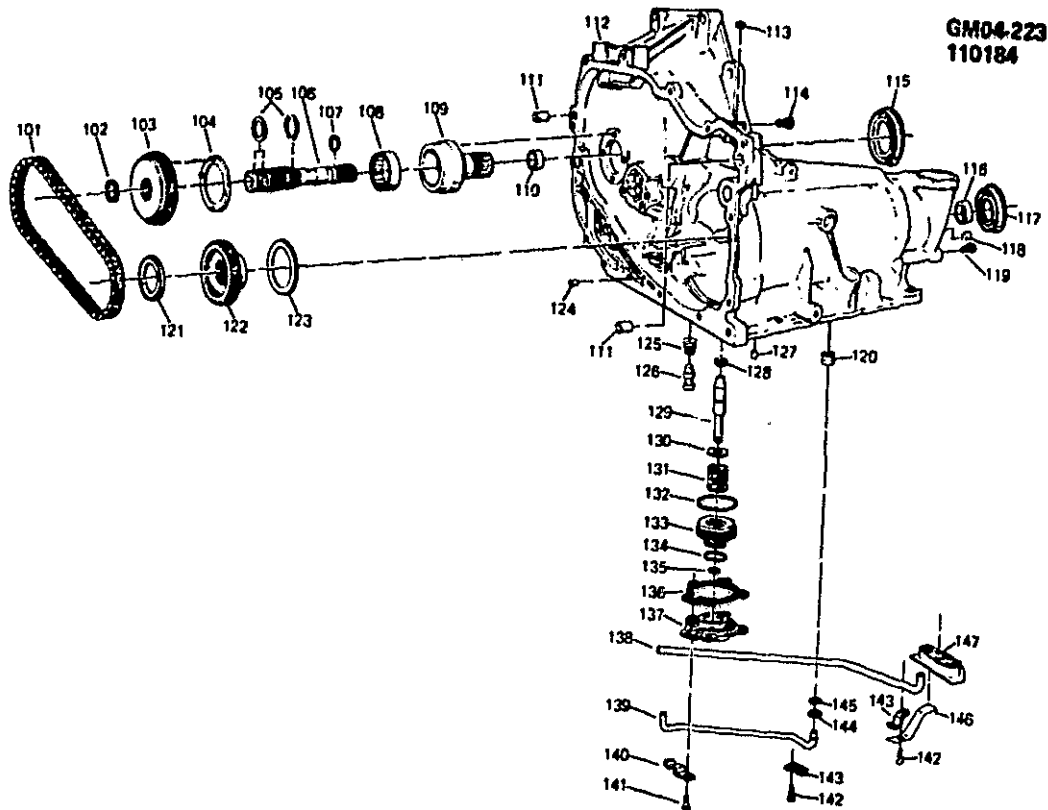

GM04-2233

1984-1988 P AUTOMATIC TRANSMISSION (MD9) THM125C CASE W/DRIVE LINK & SPROCKET

101.	C11	4.131	LINK, DRIVE	8660099
102.	C11	4.005	RING KIT, SNAP TURB SHF TO DR SPKT(*2 3)	8631948
103.	C11	4.131	SPROCKET, DR (35 TEETH)(1985-5CD)(1986-6CD-CP)(1987 7CPC-PSC) (1988)	8643210
	C11	4.131	SPROCKET, DR (33 TEETH)(1984-4PF)(1985-5PF)(1986-6PF)	8643209
104.	C11	4.131	WASHER, DR SPKT TO SUPT THR(1984-85)	8652841
	C11	4.131	WASHER, DR SPKT TO SUPT THR(1986-88)	8652841
105.	C11	4.123	RING, TURB SHF OTR(*4)	8637170
	C11	4.123	RING, TURB SHF INR	8643058
106.	C11	4.123	SHAFT, TURB-W/SLEV	8652382
107.	C11	4.131	SEAL, TURB SHF O RING (4 169)	8662686
108.	C11	4.131	BEARING, DRWN CUP DRK SPKT (PART OF #109)	8631186
109.	C11	4.131	SUPPORT, DR SPKT (INCL #108)	8652843
110.	C11	4.226	BUSHING, DR SPKT SUPT (4 131)	8628915
111.	C11	4.105	DOWEL PKG, CASE TO CASE LVR	8665946
112.	C11	4.103	CASE, TRANS (COMPL)(1984-87)	8653918
	C11	4.103	CASE, TRANS (COMPL)(1988)	8653918
113.	C11	4.282	SEAL, MAN SHF(*5)	8644709
114.	C11	4.226	BOLT, CASE CVR (MBX1 25X30)	8637266
115.	C11	4.226	SEAL, HELIX (CONV OIL)	8664812
116.	C11	4.319	BUSHING, CASE (39 O O D X 11 O)	8631119
117.	E11	5.422	SEAL, AXLE OIL	8631156
118.	C11	4.294	PLUG, PK PAWL SHF	8631016
119.		8.971	PLUG, HEX (1/4X18)	
120.	C11	4.162	SEAL, CASE TO HSG-W/PLUG (PART OF #144)	8631577
121.	C11	4.131	BEARING, DRVN SPKT THR (4 164)	9436851
122.	C11	4.131	SPROCKET, DRVN (37 TEETH)(1984-85-86-4PF-5PF-6PF)	8643224
	C11	4.131	SPROCKET, DRVN (32 TEETH)(1985-5CD)(1986-6CD-CP)(1987 7CPC-PSC) (1988)	8643223

123. C11	4.131	WASHER, DRVN SPKT TO DR SPKT THR	8637227
124. C11	4.106	PLUG, CUP (3RD OIL) 6 4MM)	8611710
125.	N.S.	SPRING, ACCUM EXH (PART OF #126)	
126. C11	4.104	VALVE KIT, ACCUM EXH CHK-W/SPR (INCL #125)	8643964
127. C11	4.106	PLUG, CASE SERVO	8628864
128. C11	4.228	SEAL, INTER SERVO (PART OF #129)	8631105
129. C11	4.228	PIN, INTER BAND-W/SEAL (NO GROOVE)(INCL #128)	8631923
	C11	4.228	PIN, INTER BAND-W/SEAL (1 GROOVE)(INCL #128)
	C11	4.228	PIN, INTER BAND-W/SEAL (2 GROOVES)(INCL #128)
130. C11	4.228	RETAINER, INTER SERVO SPR	8631925
131. C11	4.233	SPRING, INTR SERVO CUSH (657N)(*2)	8631039
132.	N.S.	RING, OIL SEAL OUTER INT SERVO (PART OF #133)	8652057
133. C11	4.228	PISTON, INT SERVO-W/SEALS(1984-85)(1986-PF)(1987-7PSC)	8652901
	C11	4.228	PISTON, INT SERVO-W/SEALS(1986-8CD-CP)(1987-7CPC)
	C11	4.228	PISTON, INT SERVO-W/SEALS(1988-8PSC)
	C11	4.228	PISTON, INT SERVO-W/SEALS(1988-8CPC)
134.	N.S.	SEAL, INTER SERVO PSTN INR (PART OF #133)	8652900
135.	8.934	RING, (TYPE TE #25)	8652911
136. C11	4.228	GASKET, INTER SERVO CVR	8652900
137. C11	4.228	COVER, INT SERVO(79)(1984-85-PF)(1986-6PF)(1987-7PSC)	8652911
	C11	4.228	COVER, INT SERVO(71)(1985-CD)(1986-6CD-CP)(1987-7CPC)
	C11	4.228	COVER, INT SERVO(64)(1988-8PSC)
	C11	4.228	COVER, INT SERVO(71)(1988-8CPC)
138. C11	4.248	PIPE, GOV OIL	8631702
139. C11	4.248	PIPE, REV OIL	8631702
140. C11	4.248	RETAINER, REV OIL PIPE TO SERVO CVR	8631703
141.	8.900	BOLT, HEX (M6X1X20) 9 8 ZC	8631704
142.	8.900	BOLT, HEX (M8X1 25X14) 10 9 PC	8631703
143. C11	4.248	RETAINER, GOV OIL PIPE	8631335
144. C11	4.184	SEAL KIT, REV OIL-W/BK UP RING (INCL #120,145)	8631330
145. C11	4.226	SEAL, REV PIPE/CASE O RING (PART OF #144)	8631334
146. C11	4.248	CLIP, CASE OIL WEIR RET(*4)	8637837
147. C11	4.248	WEIR, CASE OIL(*4)	8637836

NOTE 2 PART OF 4 005 8631948 - RING KIT, SNAP (1984-86)

NOTE 3 PART OF 4 005 8664957 - RING KIT, SNAP (1987-88)

NOTE 4 PART OF 4 123 8643996 - REPAIR KIT, TURB SHF

NOTE 5 PART OF 4 005 8631914 - GASKET KIT, W/SEALS

GM04-224
110184

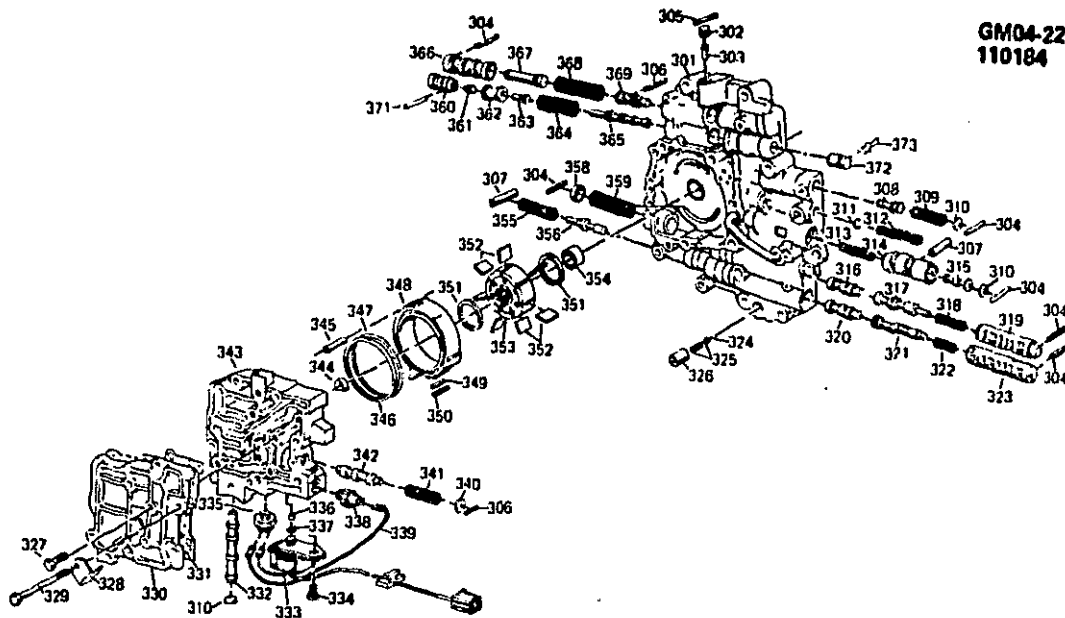

GM04-2247

1984-1988 P AUTOMATIC TRANSMISSION (MD9) THM125C PUMP & CONTROL VALVE

301.	C11	4.224	PUMP, OIL-W/CONT VLV (1984-4PF)	8852188
	C11	4.224	PUMP, OIL-W/CONT VLV (1984-5PF)(1985-5PF)(1986-6PF)	8852314
	C11	4.224	PUMP, OIL-W/CONT VLV (1985-5CD)	8852883
	C11	4.224	PUMP, OIL-W/CONT VLV (1986-6CD)	8860489
	C11	4.224	PUMP, OIL-W/CONT VLV (1986-6CP)	8860754
	C11	4.224	PUMP, OIL-W/CONT VLV (1987-7CPC)	8864104
	C11	4.224	PUMP, OIL-W/CONT VLV (1987-7PSC)	8866258
	C11	4.224	PUMP, OIL-W/CONT VLV (1988-8CPC)	8864775
	C11	4.224	PUMP, OIL-W/CONT VLV (1988-8PSC)	8866310
302.	C11	4.265	PLUG, LINE BOOST VLV	8831897
303.	C11	4.265	VALVE, LINE BOOST	8831816
304.	C11	4.265	PIN, VLV BDY VLV RET (25MM)	8828400
305.	C11	4.216	PIN, COILED SPR LINE BOOST PLUG	
308.	C11	4.265	PIN, THROT VLV BOOST BUSH	8843551
307.	C11	4.224	SLEEVE, SPR RET	8831290
308.		N.S.	VALVE, SHFT(*2)	
309.		N.S.	SPRING, SHFT(*2)	
310.	C11	4.265	PLUG, VLV BORE (14 22MM)	8825546
311.		8.899	BALL, 3/8"-STL	7826284
312.		N.S.	SPRING, PRESS RLF(*2)	
313.		N.S.	SPRING, 1-2 ACCUM(*2)	
314.		N.S.	BUSHING, 1-2 ACCUM(*2)	
315.		N.S.	VALVE, 1-2 ACCUM(*2)	
316.		N.S.	VALVE, 2-3 SHFT(*2)	
317.		N.S.	VALVE, 2-3 THROT(*2)	
318.		N.S.	SPRING, THROT VLV(*2)	
319.		N.S.	BUSHING, 2-3 THROT VLV(*2)	
320.		N.S.	VALVE, 1-2 SHFT(*2)	
321.		N.S.	VALVE, 1-2 THROT(*2)	
322.		N.S.	SPRING, THROT VLV(*2)	
323.		N.S.	BUSHING, 1-2 THROT VLV(*2)	
324.		8.899	BALL (6 3MM). (6 3MM)	104918
325.	C11	4.265	SPRING, LOW BLOW OFF-W/PLUG (1984-87)	8831768
	C11	4.265	SPRING, LOW BLOW OFF (1988)	8864458
326.	C11	4.265	PLUG, LOW BLOW OFF VLV (1984-87)	8831449
	C11	4.265	PLUG, LOW BLOW OFF VLV (1988)	8864457
327.		8.900	BOLT, HEX (M6X1X25)	
328.	C11	4.248	RETAINER, VLV BDY PIPE(*2)	8837100
329.		8.900	BOLT, AUX VLV BODY/CASE HEX (M6X1X90) 10 9 PC	11504919
330.	C11	4.228	COVER, AUX VLV BODY (1984-86)	8843645

330.	C11	4.226	COVER, AUX VLV BODY (1987-88)	8664134
331.	C11	4.226	GASKET, AUX VLV BDY CVR (1984-4PF)	8653947
	C11	4.226	GASKET, AUX VLV BDY CVR (1984-5PF)(1985-86)	8643863
	C11	4.226	GASKET, AUX VLV BDY CVR (1987-88)	8660789
332.	C11	4.116	VALVE, CONV CLU CONT	8637089
333.	C11	4.122	SOLENOID, CONV CLU-W/CLIP	8552379
334.		8.900	BOLT, (M6X1X16)	
335.	C11	4.265	SWITCH, OIL PRESS (2 PRONG)	8643710
336.	C11	4.265	PLUG, AUX VLV BDY ORIFICE	8623798
337.	C11	4.122	SEAL, SOL	8630052
338.	C11	4.265	SWITCH, VLV BDY GOV PRESS	8643710
339.	C11	4.122	WIRE, ASM (NOT REQ'D - EXPORT ONLY)	
340.	C11	4.265	PLUG, VLV BORE (1982-86)	8637863
	C11	4.265	PLUG, VLV BORE ORIFICE CUP (3 27MM)(1987)	8664135
341.	C11	4.116	SPRING, CONV CLU REG (1984-87)	8637889
342.	C11	4.116	VALVE, CONV CLU REG (1984-87)(12MM OD)	8637090
		N.S.	VALVE, CONV CLU REG (1988)(10MM OD)(*2)	
343.	C11	4.265	VALVE, AUX (1987-88)	8664131
344.	C11	4.224	SLEEVE, PUMP CVR	8631288
345.	C11	4.226	PIN, SLIDE PIV	8628273
346.		N.S.	RING, OIL SEAL-SLIDE TO CVR(*1)	
347.		N.S.	SEAL, O-RING (SLIDE)(*1)	
348.		N.S.	SLIDE, PUMP SEL (PART OF #353)	
349.		N.S.	SUPPORT, PUMP SLIDE SEAL(*1)	
350.		N.S.	SEAL, PUMP SLIDE(*1)	
351.	C11	4.226	RING, PUMP VANE	8631279
352.	C11	4.226	VANE, PUMP	8631280
353.	C11	4.224	ROTOR, OIL PUMP SEL-W/SLIDE (17 965-17 968MM)	8665951
	C11	4.224	ROTOR, OIL PUMP SEL-W/SLIDE (17 968-17 981MM)	8662904
	C11	4.224	ROTOR, OIL PUMP SEL-W/SLIDE (17 981-17 994MM)	8662905
	C11	4.224	ROTOR, OIL PUMP SEL-W/SLIDE (17 994-18 007MM)	8662908
	C11	4.224	ROTOR, OIL PUMP SEL-W/SLIDE (18 007-18 020MM)	8662907
354.	C11	4.226	BEARING, RLR PUMP SHF (1984-4PF)(*3)	8631277
	C11	4.226	BEARING, RLR PUMP SHF (1984-5PF)(1985-88)(*4)	8666375
355.		N.S.	SPRING, 3-2 VLV(*2)	
356.		N.S.	VALVE, 3-2 CONT(*2)	
358.		8.970	PLUG, CUP (687)	9421748
359.	C11	4.216	SPRING, PUMP PRIMING	8631717
360.		N.S.	BUSHING, T V BOOST VLV(*2)	
361.		N.S.	VALVE, T V BOOST(*2)	
362.		N.S.	BUSHING, REV BOOST VLV(*2)	
363.		N.S.	VALVE, REV BOOST(*2)	
364.		N.S.	SPRING, PRESS REG(*2)	
365.		N.S.	VALVE, PRESS REG(*3)	
366.		N.S.	BUSHING, T V PLGR(*3)	
367.		N.S.	PLUNGER, THROT VLV(*3)	
368.		N.S.	SPRING, THROT VLV(*3)	
369.		N.S.	VALVE, THROT(*3)	
371.	C11	4.265	PIN, VLV BDY THROT VLV BOOST BUSH	8643551
372.	C11	4.104	PLUG, BORE PRESS REG (1986-88)	8652128
373.	C11	4.338	RETAINER, HAIR PIN TYPE (1986-88)	8643202

NOTE 1 PART OF 4 226-8631947 SLIDE KIT. PUMP-W/SEALS & SUPT

NOTE 2 PART OF #301

NOTE 3 1984 1ST DES TWO PIECE PUMP SHAFT BRG & SEAL

NOTE 4 1984 2ND DES ONE PIECE PUMP SHAFT BRG & SEAL

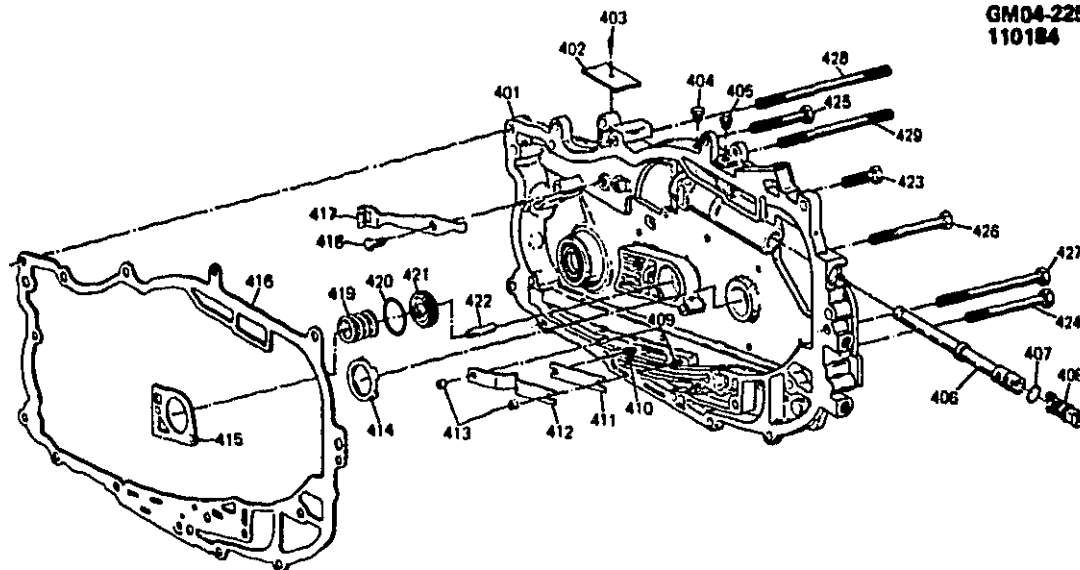

GM04-2253

1984-1988 P AUTOMATIC TRANSMISSION (MD9) THM125C CASE COVER PARTS

401. C11	4.105	COVER, TRANS CASE W/SLEV	8653969
402.	N.S.	NAMEPLATE,	
403. C11	4.003	SCREW, NAMEPLATE	8622361
404. C11	4.104	VENT, TRANS (1984)	3750810
C11	4.104	VENT, TRANS (1985-88)	8652235
405.	8.971	PLUG, HEX HD PIPE (1/8X27)	
406. C11	4.265	VALVE ASM, MAN	8666494
407. C11	4.115	SEAL, ELEC CONN O RING (4 338)	10054241
408. C11	4.115	CONNECTOR, ELEC-W/SEALS (PART OF #412)	8634383
409. C11	4.226	PIN, THERM ELEM SPR (1984-86)(PART OF #412)(*)	8631687
410. C11	4.226	PIN, THERM ELEM	8631654
411. C11	4.226	PLATE, THERM ELEM (PART OF #412)	8631719
412. C11	4.226	ELEMENT, THERM (PART OF #412)	8631739
C11	4.226	ELEMENT KIT, THERM (INCL #408 9 11 12 13)	8631956
413.	N.S.	WASHER, THERM ELEM (1984-86)(PART OF #412)(*)	
414. C11	4.131	WASHER, CASE CVR TO DR SPKT THR (1984-85)	8652868
C11	4.131	WASHER, CASE CVR TO DR SPKT THR (1986-88)	8652868
415.	N.S.	GASKET, CASE TO CASE CVR CTR (PART OF #412)	
416. C11	4.109	GASKET KIT, CASE TO CASE CVR (INCL #415)	8631979
417. C11	4.293	SPRING, MAN DETENT-W/RLR	8631748
418.	8.900	BOLT, HEX (M6X1X10)	
419. C11	4.233	SPRING, 1-2 ACCUM PSTN (1984-85)	8631168
C11	4.233	SPRING, 1-2 ACCUM PSTN (1986-88)	8652501
420. C11	4.229	RING, 1-2 ACCUM PSTN OIL SEAL	8631895
421. C11	4.228	PISTON, 1-2 ACCUM	8665920
422. C11	4.265	PIN, 1-2 ACCUM	8631164
423.	8.900	BOLT, (M8X1 25X16)	
424.	8.900	BOLT, HEX (M8X1 25X45) CAD BR	11506088
425.	8.900	BOLT, HEX (M8X1 25X25) 10 9	11500918
426.	8.900	BOLT, HEX (M8X1 25X75) 10 9 PL	11500721
427.	8.900	BOLT, HEX (M8X1 25X55) 10 9 PL	11504824
428. C11	4.105	STUD, CASE CVR TO CASE (M8X1 25X76 4)	8637161
429.	N.S.	STUD, CASE CVR TO CASE (M8X1 25X64)	

NOTE 1 FOR 1987-88 USE 8637673 PIN & WASHER ASM

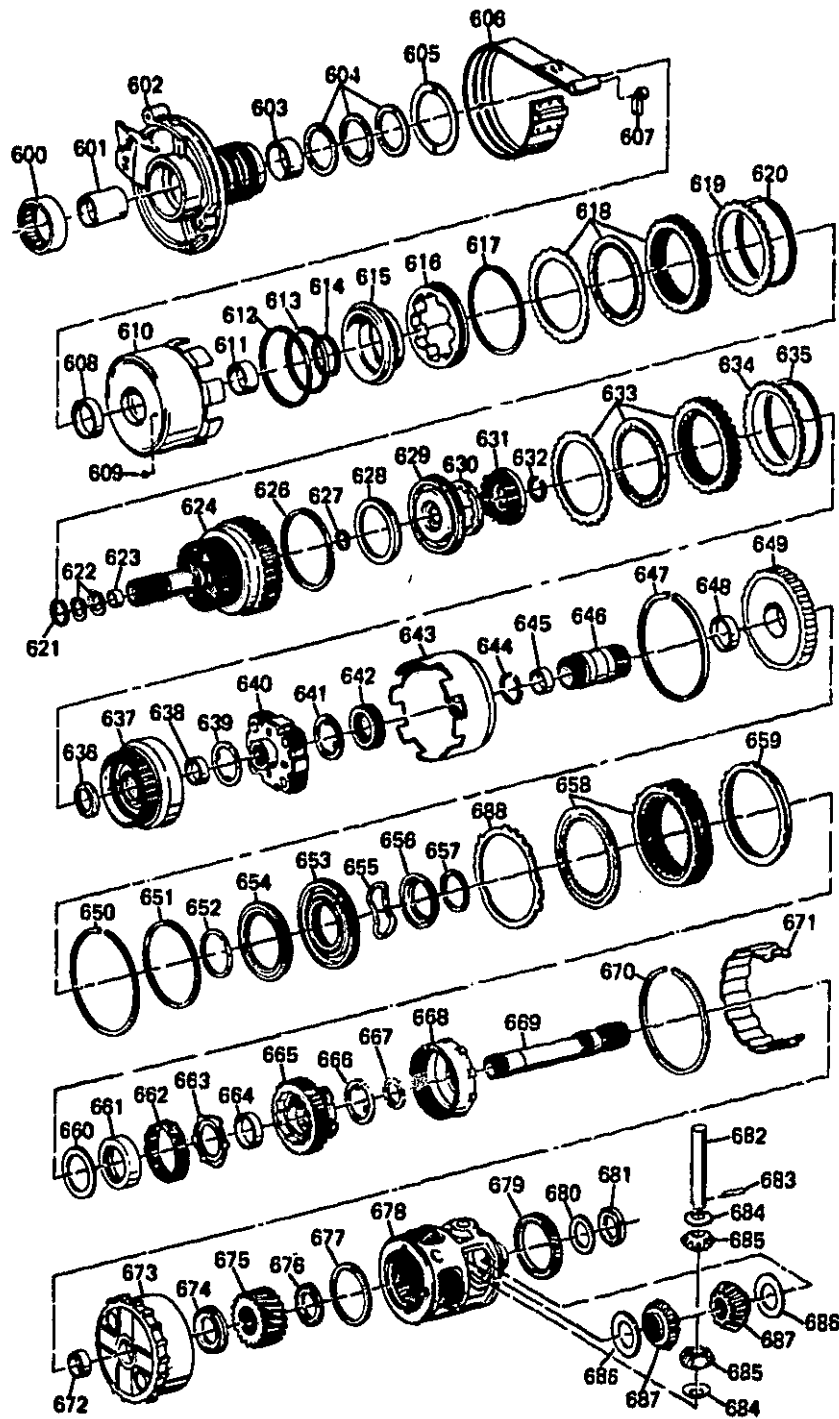

1984-1988 P AUTOMATIC TRANSMISSION (MD9) THM125C INTERNAL POWER TRAIN PARTS

600.	C11	4.131	BEARING, DR SPKT	8631190
601.		N.S.	SLEEVE, DRVN SPKT SUPT (PART OF #602)	
602.	C11	4.131	SUPPORT, DR SPKT	8652564
603.	C11	4.131	BUSHING, DR SPKT SUPT	8631900
604.	C11	4.131	RING, DR SPKT SUPT(*1.2.3.6)	8652535
605.	C11	4.169	WASHER, SUPT DIR CLU THR	8631029
606.		4.251	HOUSING & DRUM KIT, W/INTER BAND DIR CLU (1984-4PF)	8653978
		4.251	BAND KIT, INTER-W/DIR CLU HSG & DRUM (1984-5PF)(1985-88)	8653982
607.	C11	4.105	PLUG, BAND ANC HOLE	8637640
608.	C11	4.169	BUSHING, DIR CLU FRT	8631902
609.	C11	4.226	RETAINER, DIR CLU HSG CHK VLV-W/BALL	8628732
610.	C11	4.169	HOUSING & DRUM KIT, DIR CLU-W/DRUM (1984-4PF)	8653978
	C11	4.169	HOUSING, DIR CLU-W/DRUM (1984-5PF)(1985-88)	8653971
611.	C11	4.169	BUSHING, DIR CLU DRUM RR	8631901
612.		N.S.	SEAL, DIR CLU PSTN OTR(*1.2.3.5.6)	
613.		N.S.	SEAL, DIR CLU PSTN CTR(*1.2.3.5.6)	
614.		N.S.	SEAL, DIR CLU PSTN INR(*1.2.3.5.6)	
615.	C11	4.166	PISTON, DIR CLU (1984-4PF)	8631009
	C11	4.166	PISTON, DIR CLU (1984-5PF)(1985-88)	8652082
616.	C11	4.164	RING, DIR CLU APPLY-W/REL SPR (1984-4PF)(1985-5CD)(1986-6CD-CP) (1987-7CPC)	8664635
	C11	4.164	RING, DIR CLU APPLY-W/REL SPR (1984-5PF)(1985-5PF)(1986-6PF)(1987-7PSC)	8664636
	C11	4.164	RING, DIR CLU APPLY-W/REL SPR (1988-8PSC)	8664635
	C11	4.164	RING, DIR CLU APPLY-W/REL SPR (1988-8CPC)	8664636
617.	C11	4.164	RING, SNAP FWD & DIR CLU BKG (1984-4PF)	8652055
	C11	4.164	RING, SNAP FWD & DIR CLU BKG (1984-5PF)(1985-88)	8652055
618.	C11	4.163	PLATE, DIR CLU (FLAT STL)	8631026
	C11	4.163	PLATE, FWD & DIR CLU (1984-4PF)*1.2.3)	8652409
	C11	4.163	PLATE, FWD & DIR CLU (1984-5PF)(1985-88)*1.2.3.6)	8643741
619.	C11	4.163	PLATE, FWD & DIR CLU BKG (4 89MM)(1984-4PF)	8658146
	C11	4.163	PLATE, FWD & DIR CLU BKG (1984-5PF)(1985-88)	8652562
620.	C11	4.164	RING, FWD & DIR CLU BKG SNAP (1984-4PF)	8652055
	C11	4.164	RING, FWD & DIR CLU BKG SNAP (1984-5PF)(1985-88)	8652055
621.	C11	4.169	SPACER, DR SPKT TO INPUT SHF (1 89MM)(WHITE)	8631258
	C11	4.169	SPACER, DR SPKT TO INPUT SHF (2 08MM)(BLUE)	8631259
	C11	4.169	SPACER, DR SPKT TO INPUT SHF (1 28MM)(RED)	8631260
	C11	4.169	SPACER, DR SPKT TO INPUT SHF (2 48MM)(YELLOW)	8631261
	C11	4.169	SPACER, DR SPKT TO INPUT SHF (2 68MM)(GREEN)	8631262
622.	C11	4.123	RING, INPUT SHF OIL SEAL	8631048
623.	C11	4.123	BUSHING, INPUT SHF	8631903
624.	C11	4.169	HOUSING, FWD CLU (1984-4PF)	8664982
	C11	4.169	HOUSING, FWD CLU (1984-5PF)(1985-88)	8664982
626.	C11	4.166	SEAL, FWD CLU PSTN OTR(1987-88)(PART OF 629 FOR 84-86)*3.6)	8631986
627.	C11	4.166	SEAL, FWD CLU PSTN INR(1987-88)(PART OF 629 FOR 84-86)*3.6)	8631986
628.		N.S.	RING, FWD CLU APPLY	
	C11	4.166	PISTON, FWD CLU	8637973
	C11	4.166	INSERT, FWD CLU PSTN (1984-86)	8643606
	C11	4.166	INSERT, FWD CLU PSTN (1987-88)	8660548
630.		N.S.	GUIDE, REL SPR (PART OF #631)	
631.	C11	4.164	SPRING, FWD CLU REL-W/GDE	8631927
632.	C11	4.005	RING KIT, SNAP TURB SHF TO DR SPKT	8631948
633.	C11	4.163	PLATE, FWD CLU-WAVED STL	8664155
	C11	4.163	PLATE, FWD CLU-FLAT STL	8631379
	C11	4.163	PLATE, FWD CLU-FLAT FACED	8643741
634.	C11	4.163	PLATE, FWD CLU BKG (6 03MM)(1984-86)	8637880
	C11	4.163	PLATE, FWD CLU BKG (5 34MM)(1984-86)	8637881
	C11	4.163	PLATE, FWD CLU BKG (4 64MM)(1984-86)	8637882
	C11	4.163	PLATE, FWD CLU BKG (5 102-4 862MM)(1986-88)	8664160
	C11	4.163	PLATE, FWD CLU BKG (4 457-4 307MM)(1986-88)	8664161
	C11	4.163	PLATE, FWD CLU BKG (3 902-3 752MM)(1986-88)	8664162
	C11	4.163	PLATE, FWD CLU BKG (3 347-3 197MM)(1986-88)	8664163
635.	C11	4.164	RING, FWD CLU BKG SNAP (1984-4PF)	8652055
	C11	4.164	RING, FWD CLU BKG SNAP (1984-5PF)(1985-88)	8652055
636.	C11	4.158	WASHER, INPUT SHF THR (1984-85)	8631747
	C11	4.158	WASHER, INPUT SHF THR (1986-87)	8652759
	C11	4.158	WASHER, INPUT SHF THR (1988)	8664762
637.	C11	4.158	GEAR, INPUT INT-W/BUSH	8631049
638.	C11	4.158	BUSHING, INPUT INT GR	8631904
639.	C11	4.159	WASHER, INPUT CARR THR	8631063
640.	C11	4.175	CARRIER, INPUT (COMPL)	8631681
641.	C11	4.159	WASHER, INPUT CARR THR	8631082
642.	C11	4.159	GEAR, INPUT SUN	8652644

843.	C11	4.175	DRUM, INPUT(1984)(1985-5PF)(1986-88)	8652435
	C11	4.175	DRUM, INPUT-W/TUBE (1985-5CD)	8652435
844.	C11	4.159	RING, INPUT DRUM/SUN GR SNAP (2 22MM)(PINK)(*)	8631802
845.	C11	4.159	BUSHING, REACT SUN	8631908
846.	C11	4.159	GEAR, REACT SUN	8631845
847.	C11	4.162	RING, LOW & REV CLU HSG/CASE SNAP	8631549
848.	C11	4.180	BUSHING, LO & REV CLU HSG	8631905
849.	C11	4.189	HOUSING, LO & REV CLU W/BUSH	8680814
850.	C11	4.162	RING, LO & REV CLU HSG/CASE SNAP (PART OF #632)	8631549
851.	C11	4.166	SEAL KIT, LO & REV CLU (INCL 652)(*)1.2.3.6)	8631913
852.		N.S.	SEAL, LO & REV PSTN INR (PART OF #651)(*)1.2.3.6)	
853.	C11	4.166	PISTON, APPLY RING LO & REV CLU (1984-4PF)	8652024
	C11	4.166	PISTON, APPLY RN LO & REV CLU (1984-5PF)(1985-86)	8652024
	C11	4.166	PISTON, APPLY RN LO & REV CLU (1987-88)	8684150
854.	C11	4.166	INSERT, LO & REV CLU PSTN	8643490
855.	C11	4.164	SPRING, LO & REV CLU REL (4 189)	8628222
856.	C11	4.164	RETAINER, LO & REV CLU SPR (1984-4PF)(1986-87)	8631075
	C11	4.164	RETAINER, LO & REV CLU SPR (1984-5PF)(1985)	8684861
	C11	4.164	RETAINER, LO & REV CLU SPR (1988)	8684961
857.	C11	4.005	RING KIT, SNAP TURB SHF TO DR SPKT	8631948
858.	C11	4.163	PLATE, LO & REV CLU (WAVED STL)	8684141
	C11	4.163	PLATE, LO & REV CLU (FLAT FACED)(1984-86)	8680812
	C11	4.163	PLATE, LO & REV CLU (FLAT FACED)(1987-88)	8680812
	C11	4.163	PLATE, LO & REV CLU (FLAT STL)(1984-86)	8652027
859.	C11	4.163	PLATE, LO & REV CLU BKG (1FLAT FACFD)	8688661
860.	C11	4.180	SPACER, REV CLU HSG/LO RACE (1 05MM)(ID 1)	8631241
	C11	4.180	SPACER, REV CLU HSG/LO RACE (1 47MM)(ID 2)	8631242
	C11	4.180	SPACER, REV CLU HSG/LO RACE (1 89MM)(ID 3)	8631243
	C11	4.180	SPACER, REV CLU HSG/LO RACE (2 31MM)(ID 4)	8631244
	C11	4.180	SPACER, REV CLU HSG/LO RACE (2 73MM)(ID 5)	8631245
	C11	4.180	SPACER, REV CLU HSG/LO RACE (3 15MM)(ID 6)	8631246
861.	C11	4.180	RACE, LOW RLR CLU	8631093
862.	C11	4.180	ROLLER, LO CLU	8652403
863.	C11	4.180	WASHER, REACT CARR/LO RACE THR	8631227
864.	C11	4.180	BUSHING, REACT CARR	8631905
865.	C11	4.175	CARRIER, REACT	8680048
866.	C11	4.176	WASHER, REACT CARR TO INT GR THR	8628188
867.	C11	4.159	BEARING, REACT INT GR TO CARR THR	8628962
868.	C11	4.187	GEAR, REACT INT	8652236
869.	C11	4.175	SHAFT, FINAL DR SUN GR	8652388
870.	C11	4.164	RING, FINAL DR INT SPCR TO CASE	8631078
871.	C11	4.176	SPACER, FINAL DR INT GR	8652022
872.	C11	4.319	BUSHING, FINAL DR INT GR	8631119
873.	C11	4.187	GEAR, FINAL DR INTER W/BUSH	8631117
874.	C11	4.187	BEARING, SUN GR/INT GR THR	8631116
875.	C11	4.187	GEAR, FINAL DR SUN (1984)(1985-86-5PF-6PF)(1987-7PSC)	8631155
	C11	4.187	GEAR, FINAL DR SUN (1985-5CD)(1986-6CD)	8644237
	C11	4.187	GEAR, FINAL DR SUN (1986-6CP)(1987-7CPC)(1988-8CPC)	8644114
	C11	4.187	GEAR, FINAL DR SUN (1988-8PSC)	8631155
876.	C11	4.159	BEARING, CARR/SUN GR (1984-85)(1986-6CD-CP)(1987-7CPC)	8646254
	C11	4.159	BEARING, CARR/SUN GR (1986-6PF)(1987-7PSC)(1988)	8628962
877.		8.934	RING, PIN RET (TYPE T M80 PL)	11501328
878.	C11	4.175	CARRIER KIT, FINAL DR-W/PIN (1984-4PF-5PF)(1985-5PF)(1986-6PF)(1987-7PSC)(1988-8PSC)	8653941
	C11	4.175	CARRIER KIT, FINAL DR-W/PIN (1985-5CD)(1986-6CD)	8643990
	C11	4.175	CARRIER KIT, FINAL DR-W/PIN (1986-6CP)(1987-7CPC)	8643963
	C11	4.175	CARRIER KIT, FINAL DR-W/PIN (1988-8CPC)	8643963
879.	C11	4.258	GEAR, GOV DRIVE (PART OF #678)	8631571
880.	C11	4.176	WASHER, DIFF CARR/CASE THR (1 45MM)(ID 0)	8631420
	C11	4.176	WASHER, DIFF CARR/CASE THR (1 55MM)(ID 1)	8631421
	C11	4.176	WASHER, DIFF CARR/CASE THR (1 65MM)(ID 2)	8631422
	C11	4.176	WASHER, DIFF CARR/CASE THR (1 75MM)(ID 3)	8631423
	C11	4.176	WASHER, DIFF CARR/CASE THR (1 85MM)(ID 4)	8631424
	C11	4.176	WASHER, DIFF CARR/CASE THR (1 95MM)(ID 5)	8631425
	C11	4.176	WASHER, DIFF CARR/CASE THR (2 05MM)(ID 6)	8631426
	C11	4.176	WASHER, DIFF CARR/CASE THR (2 15MM)(ID 7)	8631427
	C11	4.176	WASHER, DIFF CARR/CASE THR (2 25MM)	8631428
	C11	4.176	WASHER, DIFF CARR/CASE THR (2 35MM)	8631429
881.	C11	4.176	BEARING, DIFF CARR/CASE THR	8631382
882.		N.S.	SHAFT, DIFF PIN(*4)	
883.		N.S.	PIN, DIFF PIN SHF RET(*4)	
884.		N.S.	WASHER, PIN THR(*4)	
885.		N.S.	PINION, DIFF(*4)	
886.		N.S.	WASHER, DIFF SI GR THR(*4)	
887.		N.S.	GEAR, DIFF SI(*4)	

888. C11 4.163 PLATE, LOW & REV CLU (WAVED STL)

8884141

NOTE 1 PART OF 4 005 8653931 - OVERHAUL KIT (1984 4PF)
NOTE 2 PART OF 4 005 8653990 - OVERHAUL KIT (1984-5PF)(1985)
NOTE 3 PART OF 4 005 8652902 - OVERHAUL KIT (1986-87)
NOTE 4 PART OF 4 175 8637919 - GEAR KIT, SI & PIN
NOTE 5 PART OF 4 166 8631911 - SEAL KIT, DIR CLU PSTN
NOTE 6 PART OF 4 005 8652995 - OVERHAUL KIT (1988)

GM04-227
110188

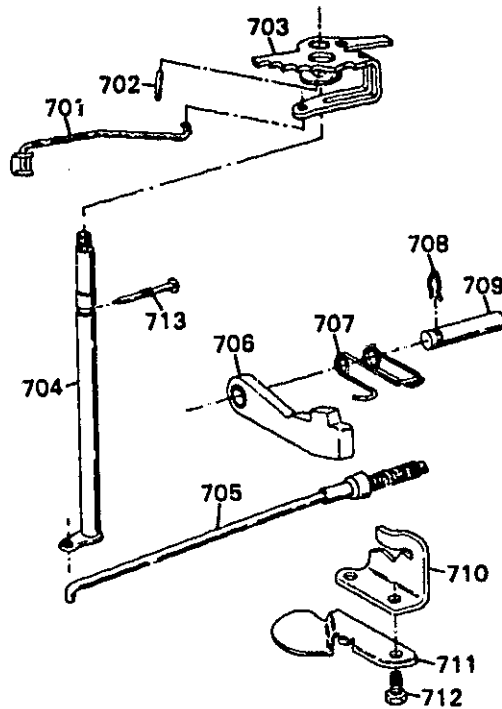

KH0020-125C

GM04-2273

1984-1988 P AUTOMATIC TRANSMISSION (MD9) THM125C PARK LOCK & INSIDE DETENT LEVER

701.	C11	4.265	ROD, W/RET. MAN VLV	8831721
702.		8.939	PIN,SPG TYPE A 3/16X1 1/8 SS PL(ARI)	12338111
703.		N.S.	LEVER & HUB, MAN DETENT (PART OF #704)	
704.	C11	4.275	SHAFT, MAN-W/LVR & PIN (INCL #702,3.4)(1984-87)	8884924
	C11	4.275	SHAFT, MAN-W/LVR & PIN (INCL #702,3.4)(1988)	8884925
705.		N.S.	ACTUATOR, PK BRK (PART OF #706)	
706.	C11	4.294	PAWL, PK BRK-W/ACT (INCL #705)	8831995
707.	C11	4.295	SPRING, PK PAWL RTN	8831880
708.		8.934	RETAINER, SPR (7/32X1/16) ZC	451788
709.	C11	4.294	SHAFT, PK LK PAWL	8831182
710.	C11	4.290	BRACKET, PK LK	8831184
711.	C11	4.197	BRACKET, DIPSTICK STOP	8837189
712.		8.900	BOLT, HEX (M8X1 25X20) 10 0 PZOR	11508887
713.	C11	4.275	PIN, MAN SHF TO CASE	8831532

2P04-009
012585

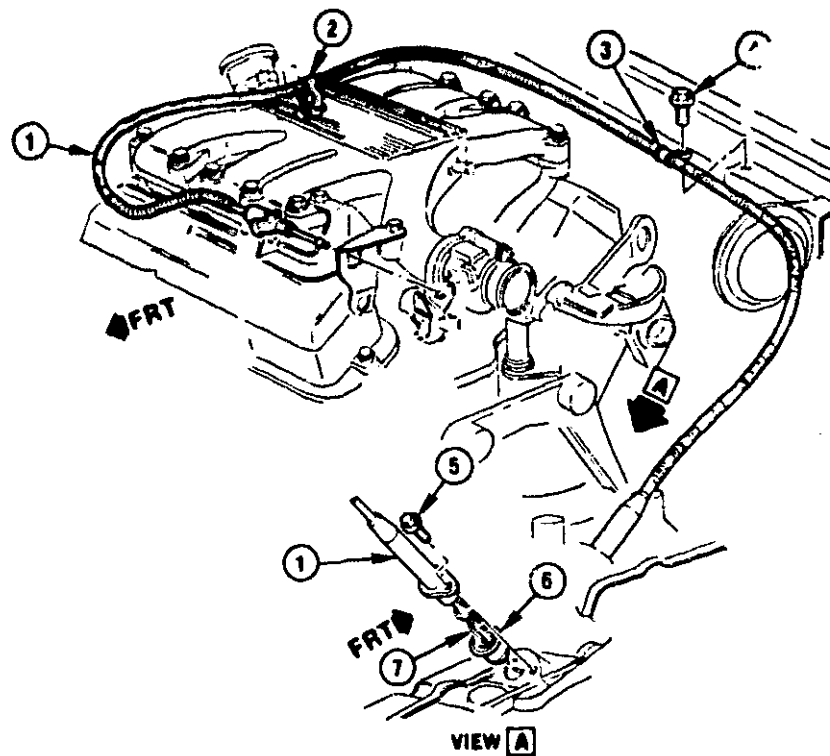

2P04-009

1985-1988 P AUTOMATIC TRANSMISSION (MD9) THM125C THROTTLE VALVE CABLE-2.8L V6 (L44/2.

9)

1.	C11	4.050	CABLE, TRANS THROT VLV	10042208
2.	C11	4.052	CLIP, TRANS THROT VLV CBL(3 885)	10035494
3.		N.S.	CLIP, CABLE	
4.		8.977	SCREW, HWH TAP (M6 3X1 81X1 3) PZOR	
5.		8.900	BOLT, HEX W CON WA (M6X1X15) PZOR	
6.	C11	4.050	SEAL, TRANS THROT VLV CBL MULTI LIP	25518260
7.	C11	4.275	LINK, THROT EVR TO CBL	8831885

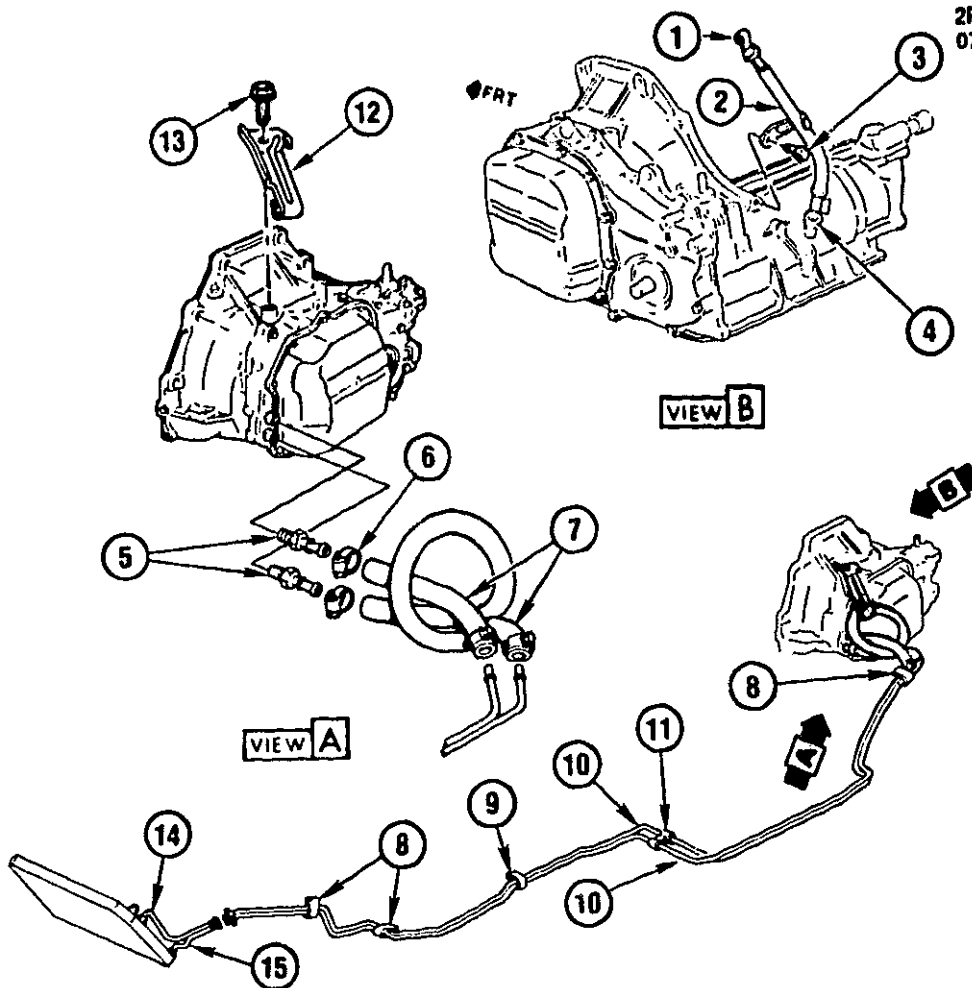

2P04-006

1984-1985 P FILLER TUBE & OIL COOLER PIPES THM125C A.T. (MD9)

1.	C11	4.133	INDICATOR, TRANS OIL LVL	10027492
2.	C11	4.133	TUBE, TRANS OIL TUBE	10027463
3.		8.900	BOLT, HEX (M8 X 1 25 X 20)	
4.	C11	4.133	SEAL, TRANS OIL FIL TUBE MULTI-LIP	1259475
5.		8.983	NUT, INV FLR 5/16" TUBE (1/2".20 STL)	
6.		8.948	CLAMP, WORM GEAR HEX SLOT SCREW (250 X 625) SS	
7.		8.962	HOSE, (7 9MM X 3050 MM LGTH)(# 1)	
8.		8.960	CLIP, CLSD STL (1/4" X 3/8" TYPE 2)	
9.	C11	4.128	RETAINER, TRANS OIL CLR PIPE TO UNDERBODY (SIDE MTG HOLE)	10095347
10.	A10	8.964	TUBING, (25FT X 5/16"ID)(# 1)	
		3.163	SHIELD, PIPE (5/16" O D X 95"X# 1)	10038499
11.		N.S.	CLIP, TRANS OIL CLR PIPE TO UNDERBODY (CTR MTG HOLE)	
12.	C11	4.128	BRACKET, TRANS OIL CLR PIPE LWR HOSE	10038063
13.		8.900	BOLT, HEX FLG (M10X1 5X20)	
14.		N.S.	PIPE, OIL-UPPER	
15.		N.S.	PIPE, OIL-LOWER	

NOTE 1 CUT AS REQUIRED

2P04-012
050487

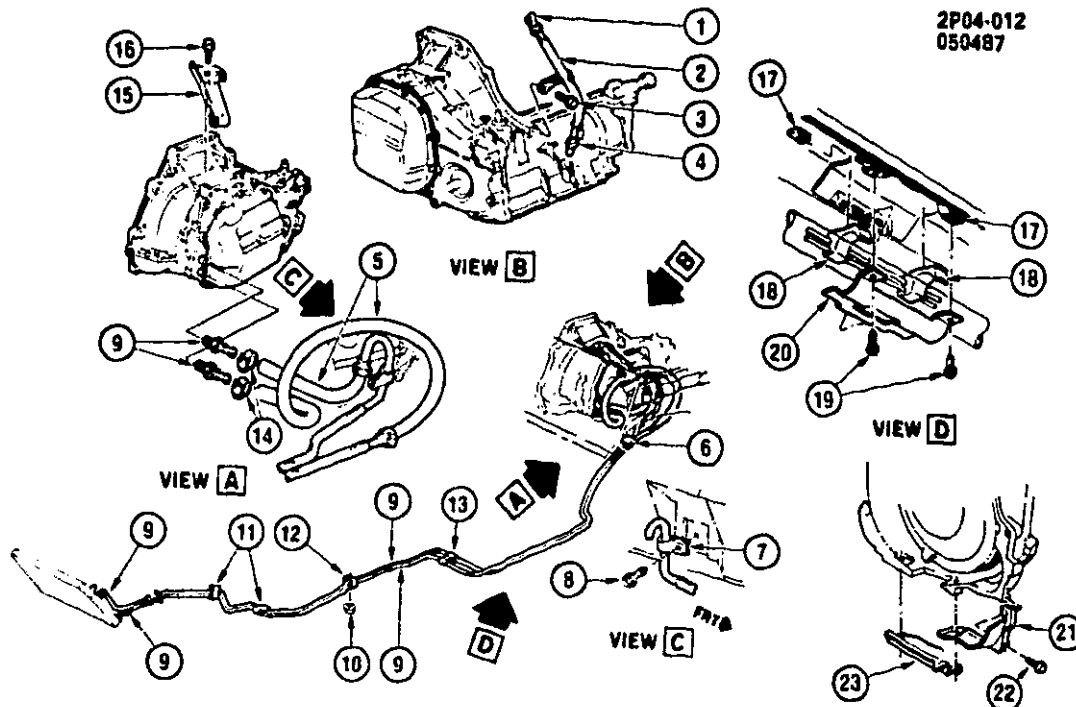

2P04-012

1986-1988 P FILLER TUBE & OIL COOLER PIPES THM125C A.T. (MD9)

1.	C11	4.133	INDICATOR, TRANS OIL LVL	10038243
2.	C11	4.133	TUBE, TRANS OIL FIL	10038244
3.		8.900	BOLT, HEX (M8X1 25X20)	11508887
4.	C11	4.133	SEAL, TRANS OIL FIL TUBE MULTI-LIP	1259475
5.		8.962	HOSE, (7 9 MM X 3050 MM LGTH)(* 1)	25508418
6.		N.S.	CLAMP, OIL CLR PIPE (3 163)	
7.		8.950	CLIP, CLSD STEEL (7/16"X5/16")	25526629
8.		8.977	BOLT, HEX W/FL WA (M6 3X1 81X20)	12337828
9.		8.984	TUBING, BULK(* 1)	1324714
		8.963	NUT, INV FLR (5/16" TUBE 1/2"-20)	9439894
10.		8.917	NUT, HFH (M6X1 X6 5) 9 ZOR	11503747
11.		N.S.	CLAMP, OIL CLR PIPE (3 163)	
12.	C11	4.128	RETAINER, OIL CLR PIPE	10095347
13.		N.S.	CLIP, OIL CLR	
14.		8.948	CLAMP, WORM GEAR HEX SLOT SCREW (250 X 625) SS	25518880
15.	C11	4.128	BRACKET, OIL CLR LWR HOSE	10041179
16.		8.977	SCREW, HEX HD MA (M1 25X25) 9 8 PC	11502685
17.		8.921	NUT, TYPE P-WU SPR (M6 3X1 81) PHOS	11514290
18.	N18	1.159	INSULATOR, RAD INL PIPE RR	10029873
19.		8.977	BOLT, HWH TAP (M6 3X1 81X20) PEOR 13-OD	22527475
20.	N18	1.166	CLAMP, RAD PIPE OTLT-INL REAR	10029872
21.	C11	4.115	COVER, TRANS CONV FRT (2 8-9)(1986-88)	10034035
	N13	0.679	COVER, TRANS CONV FRT (2 5R)W/A T (MD9)(1988)	10054248
22.		8.977	SCREW, HWH TAP (M6 3X1 81X20)(13 OD)PEOR	11508566
23.	C11	4.113	COVER, TRANS CONV RR (2 8-9)(1986-88)	10034034
	N13	0.679	COVER, TRANS CONV RR (2 5R)W/A T (MD9)(1988)	10054249

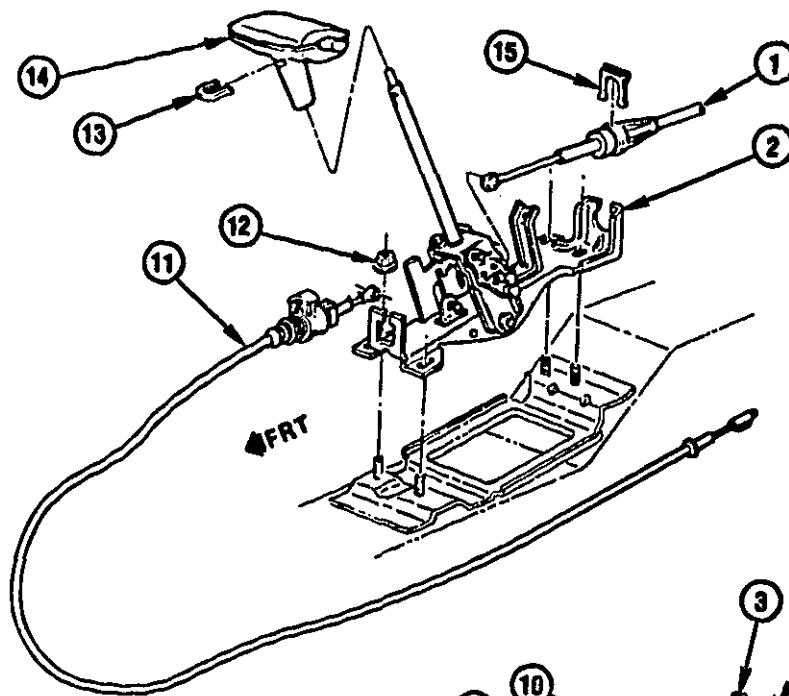

2P04-005
062393

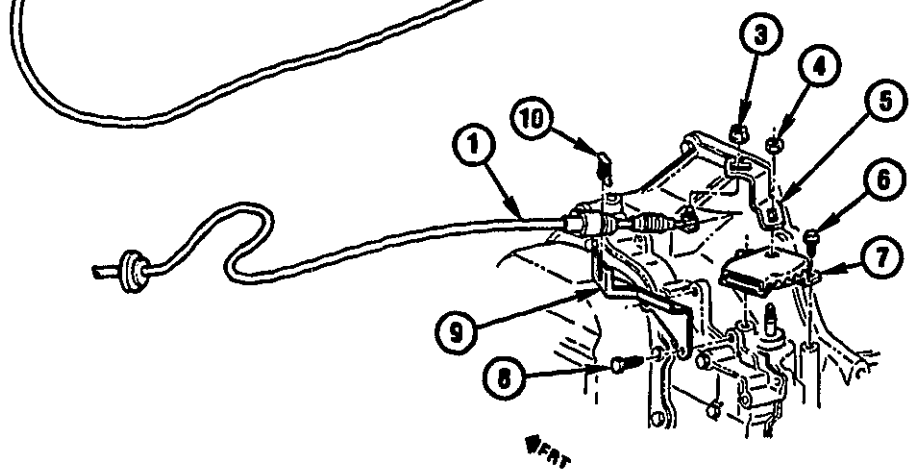

2P04-005

1984 P SHIFT CONTROL/AUTOMATIC TRANSMISSION FLOOR

1.	C11	4.047	CABLE, TRANS RANGE SEL LVR (INCL GROMMET & PIN)	10035430
	C11	4.008	GROMMET, TRANS CONT CBL	10017820
	C11	4.047	PIN, TRANS RANGE SEL CVR CBL	10023799
2.	C11	4.004	CONTROL, TRANS	10037764
3.		8.915	NUT, HEX STYLE 1 (M8 X 1.25)	
		8.929	WASHER (5/16" X 47/64" X 1/16" ZC)	
4.		8.915	NUT, HEX (M10 X 1.5 X 9)	
5.	C11	4.045	LEVER, TRANS RANGE SEL	10029180
6.		8.900	BOLT, SPR WA & MET HEX (M8 X 1.25 X 18)	
7.	C11	4.054	SWITCH, NEU START & BK LP	1994255
8.		8.900	BOLT, HEX HD (M8 X 1.25 X 16)	
9.	C11	4.047	BRACKET, TRANS RANGE SEL LVR CBL	10023801
10.	C11	4.047	RETAINER, TRANS CONT LVR CBL	12338095
11.	C11	4.047	CABLE, TRANS PK LK	10039712
12.		8.917	NUT, HEX FLG (M8 X 1.25)	
13.	C11	4.006	RETAINER, CONT LVR HDL	10028352
14.	C11	4.006	HANDLE, TRANS CONT LVR (GRAPHITE)	10029904
	C11	4.006	HANDLE, TRANS CONT LVR (DOESKIN)	10029905
15.	C11	4.008	RETAINER, RANGE SEL LVR CBL TO CONT	477093

2P04-008
071185

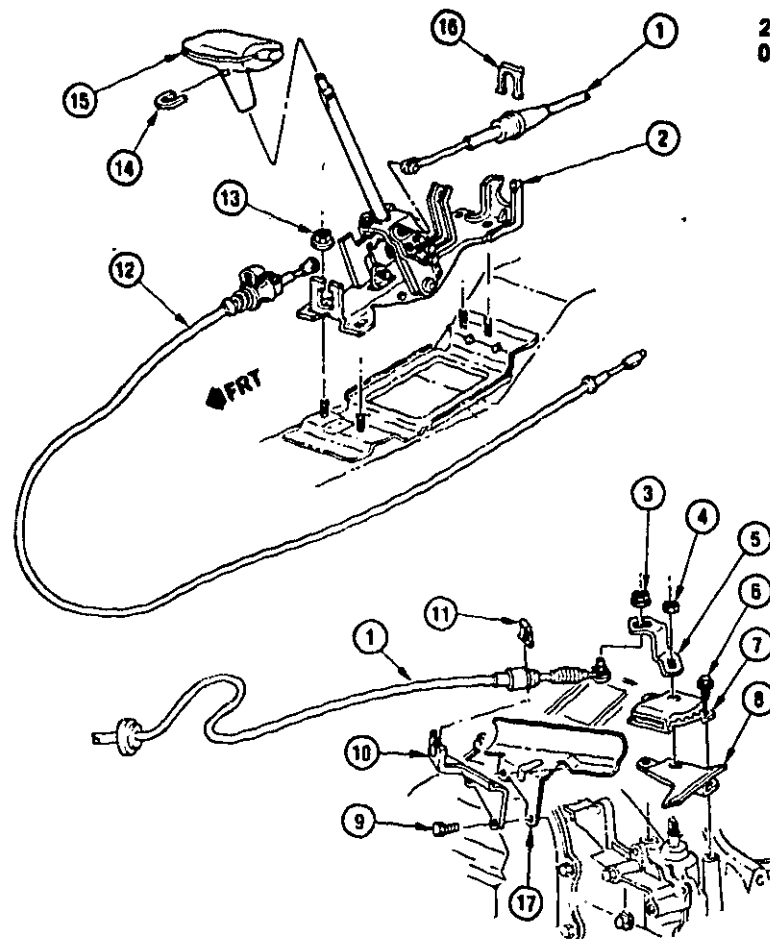

2P04-008

1985 P SHIFT CONTROL/AUTOMATIC TRANSMISSION FLOOR

1.	C11	4.047	CABLE, TRANS RANGE SEL LVR	10035430
	C11	4.008	GROMMET, TRANS CONT CBL	10017820
	C11	4.047	PIN, TRANS RANGE SEL LVR CBL	10023799
2.	C11	4.004	CONTROL, TRANS	10037784
3.		8.915	NUT, HEX STYLE 1 (M8 X 1 25)	
		8.929	WASHER, (5/16"X 47/64"X1/16")	
4.		8.915	NUT, HEX (10X1 5X9)	
5.	C11	4.045	LEVER, TRANS RANGE SEL	10029180
6.		8.900	BOLT, SPR WA & MET HEX (M8X1 25X18)	
7.	C11	4.054	SWITCH, NEU START & BK LP	1994255
8.	C11	4.054	SHIELD, TRANS NEU START SW	10035341
9.		8.900	BOLT, HEX HD (M8-1.25X16)	
10.	C11	4.047	BRACKET, TRANS RANGE SEL LVR CBL	10023801
11.	C11	4.047	RETAINER, RANGE SEL LVR CBL TO MTG BRK	12338095
12.	C11	4.047	CABLE, TRANS PK LK	10039712
13.		8.917	NUT, HEX FLG (M8-1 25)	
14.	C11	4.008	RETAINER, CONT LVR HDL	10028352
15.	C11	4.008	HANDLE, TRANS CONT LVR(GRAPHITE)(EXC NP5)	10029904
	C11	4.008	HANDLE, TRANS CONT LVR(MED DK DOESKIN)(EXC NP5)	10029906
16.	C11	4.008	RETAINER, RANGE SEL LVR CBL TO CONT	477093
17.	C11	4.047	SHIELD, TRANS RANGE SEL LVR CBL HT	10038168

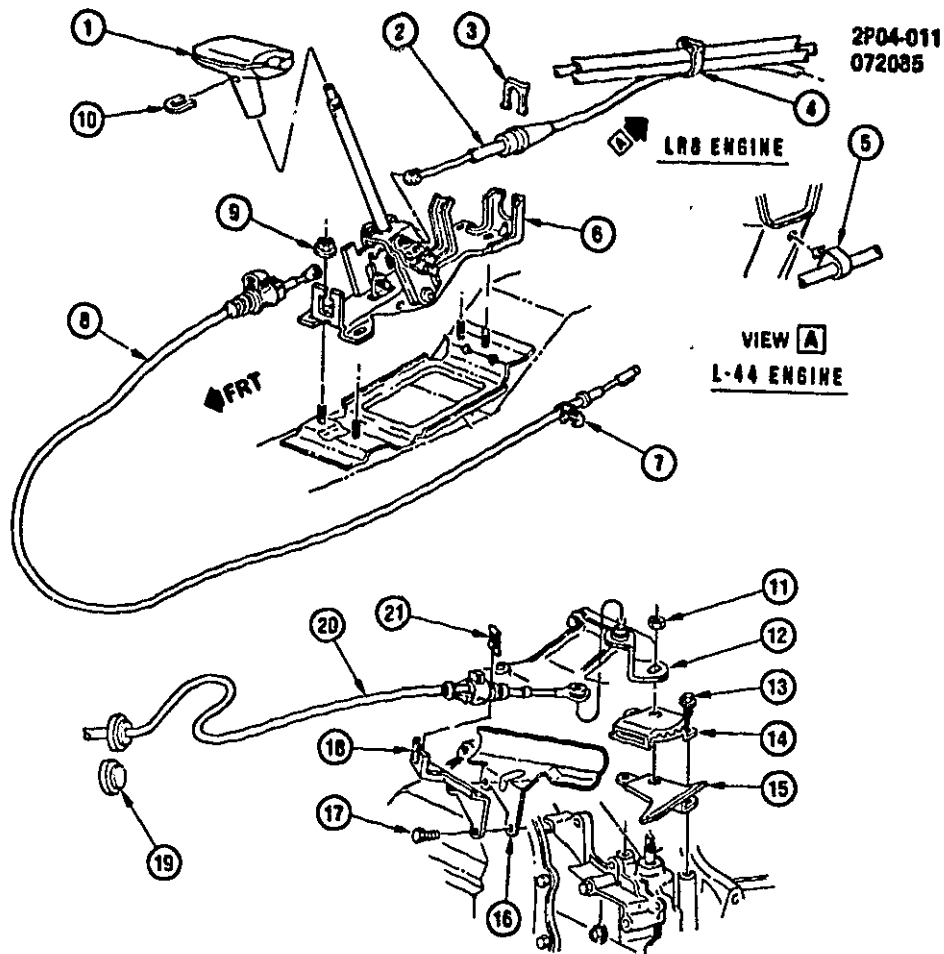

1986-1988 P SHIFT CONTROL/AUTOMATIC TRANSMISSION FLOOR

1.	C11	4.008	HANDLE, TRANS CONT LVR(*1)	10029904
2.	C11	4.047	CABLE, TRANS RANGE SEL LVR (1986-88)	10040889
3.	C11	4.008	RETAINER, RANGE SEL LVR CBL TO CONT	477093
4.	N18	1.166	CLAMP, WORM TYPE (5/6" TO 1 06" DIA)	22518665
5.		8.985	RETAINER, PLASTIC 7" ADJ STRAP	3816659
6.	C11	4.004	CONTROL, TRANS (MD9)	10037764
7.	N22	2.559	CLIP, PK LK CBL	1233599
8.	C11	4.047	CABLE, TRANS PK LK	10039712
9.		8.917	NUT, HFH (M8X1 25X7 5)	11507036
10.	C11	4.008	RETAINER, CONT LVR HDL	10028352
11.		8.915	NUT, HEX (M10 X 1 5)	11505057
12.	C11	4.045	LEVER, TRANS RANGE SEL (1986-87)	10039871
	C11	4.045	LEVER, TRANS RANGE SEL (1988)	10046661
13.		8.900	BOLT, SPR WA & MET HEX (M8 X 1 25 X 18)	11048283
14.	C11	4.054	SWITCH, NEU START & BK LP	1994255
15.		4.054	SHIELD, TRANS NEU START SW	10035341
16.	C11	4.047	SHIELD, TRANS RANGE SEL LVR CBL HT (1986-87)	10036188
17.		8.900	BOLT, HEX (M8X1 25X18)	11509589
18.	C11	4.047	BRACKET, TRANS RANGE SEL LVR CBL	10039873
19.		N.S.	PLUG, TRANS RANGE SEL LVR CBL	
20.	C11	4.047	CABLE, TRANS RANGE SEL LVR (1986-88)	10040889
21.	C11	4.047	RETAINER, RANGE SEL LVR CBL TO MTG BRKT	12338095

NOTE 1 SEE PARTS CATALOG FOR ADDITIONAL USAGE

GM04-255
080885

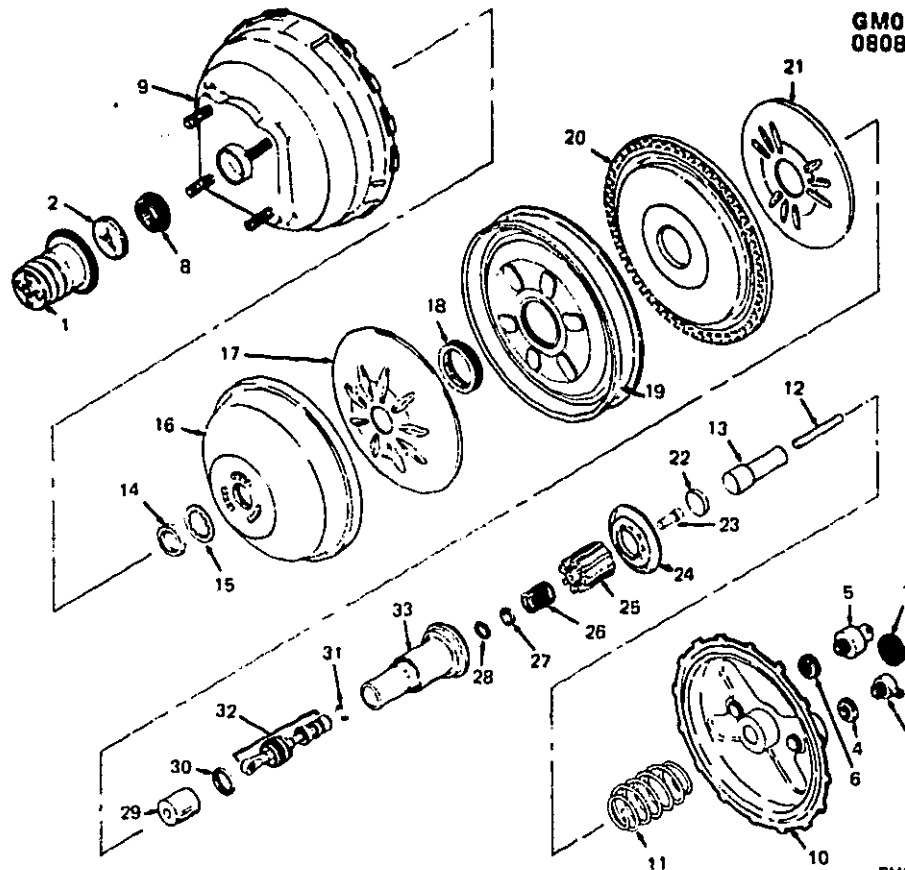

DM5189E121

GM04-255

1985-1987 P BRAKE BOOSTER/VACUUM (DUAL DIAPHRAGM)(MORAINÉ)

NOTE SEE CHART IN GROUP FOR USAGE

1.	N.S.	BOOT>(* 1,2,7)
2.	N.S.	SILENCER>(* 1,2,4)
3.	N.S.	VALVE, VACUUM CHECK(* 1,2,3)
4.	N.S.	GROMMET>(* 1,2,3)
5.	N.S.	SWITCH, VACUUM (SOME MODELS)(* 1,2,5)
6.	N.S.	GROMMET>(* 1,2,5)
7.	N.S.	SEAL, FRT HOUSING(* 1,2)
8.	N.S.	BEARING, PRIM PISTON(* 1,2)
9.	N.S.	HOUSING, RR(* 1)
10.	N.S.	HOUSING, FRT(* 1)
11.	N.S.	SPRING, RETURN(* 1)
12. E3	4.924	ROD, VAC PWR BOOST PISTON(* 1)
13.	N.S.	RETAINER, REACTION(* 1)
14.	N.S.	SILENCER, POWER HEAD(* 1,2,4)
15.	N.S.	RETAINER, DIAPHRAGM(* 1,2)
16.	N.S.	DIAPHRAGM, PRIM(* 1,2)
17.	N.S.	PLATE, PRIM SUPPORT(* 1)
18.	N.S.	BEARING, PISTON SECD(* 1,2)
19.	N.S.	DIVIDER, HOUSING(* 1)
20.	N.S.	DIAPHRAGM, SECD(* 1,2)
21.	N.S.	PLATE, SUPPORT SECD(* 1)
22.	N.S.	DISC REACTION>(* 1,2,6)
23.	N.S.	PISTON, REACTION(* 1,6)
24.	N.S.	RETAINER, BODY REACTION(* 1,4,6)
25.	N.S.	BODY REACTION(* 1,6)
26.	N.S.	SPRING, AIR VALVE(* 1,4)
27.	N.S.	BUMPER, REACTION(* 1,2,4)

28.	N.S.	RING, RETAINING(* 1.2.4)
29.	N.S.	FILTER>(* 1 2.4)
30	N.S.	RETAINER>(* 1.4)
31.	N.S.	O-RING>(* 1.4)
32.	N.S.	ROD ASM, AIR VALVE (PUSH)(* 1.4)
33.	N.S.	PISTON, POWER(* 1.6)

NOTE 1 SERVICE PWR BOOSTER, GROUP 4 901 (INCLS #1 THRU 33)

NOTE 2 PWR BOOS REPAIR KIT, GROUP 4 898 (INCLS #1 THRU 8.14.15.16.18.20.22.27.28.29)

NOTE 3 VALVE & GROMMET, GROUP 4 955 (INCLS #3.4)

NOTE 4 AIR VALVE (PLUNGER & VLV), GROUP 4 918 (INCLS #2.24.26 THRU 32)

NOTE 5 VACUUM SWITCH KIT, GROUP 4 918 (INCLS #5,6)

NOTE 6 PISTON KIT, GROUP 4 922 (INCLS #22.23.24.25.33)

NOTE 7 BOOT REPAIR KIT, GROUP 4 940 (INCLS #1.2.24)

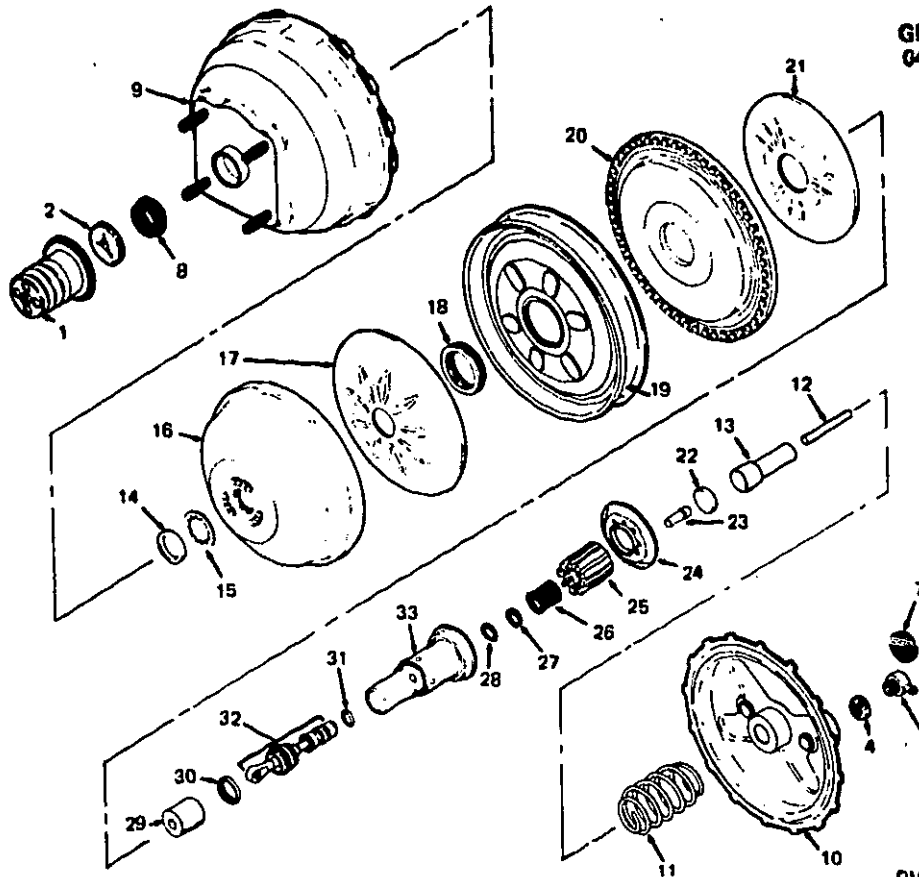

1988 P BRAKE BOOSTER/VACUUM (DUAL DIAPHRAGM)(MORAINE)

NOTE SEE CHART IN GROUP FOR USAGE

1.	D26	4.659	BOOT>(*1,2)
2.		N.S.	SILENCER>(*1,2,3)
3.		N.S.	VALVE, VACUUM CHECK(*1,2,4)
4.		N.S.	GROMMET>(*1,2,4)
7.		N.S.	SEAL, FRT HOUSING(*1,2)
8.		N.S.	BEARING, PRIMARY PISTON(*1,2)
9.		N.S.	HOUSING, REAR(*1)
10.		N.S.	HOUSING, FRT(*1)
11.		N.S.	SPRING, RETURN(*1)
12.	E3	4.924	ROD, PISTON (GAGED)(*1)
13.		N.S.	RETAINER, REACTION(*1)
14.		N.S.	SILENCER, POWER HEAD(*1,2)
15.		N.S.	RETAINER, DIAPHRAGM(*1,2)
16.		N.S.	DIAPHRAGM, PRIMARY(*1,2)
17.		N.S.	PLATE, PRIMARY SUPPORT(*1)
18.		N.S.	BEARING, PISTON SECD(*1,2)
19.		N.S.	DIVIDER, HOUSING(*1)
20.		N.S.	DIAPHRAGM, SECD(*1,2)
21.		N.S.	PLATE, SUPPORT SECD(*1)
22.		N.S.	DISC, REACTION(*1,2,5)
23.		N.S.	PISTON, REACTION(*1,5)
24.		N.S.	RETAINER, BODY REACTION(*1,3,5)
25.		N.S.	BODY, REACTION(*1,5)
26.		N.S.	SPRING, AIR VALVE(*1,3)
27.		N.S.	BUMPER, REACTION(*1,2,3)
28.		N.S.	RING, RETAINER(*1,2,3)
29.		N.S.	FILTER(*1,2,3)

30. N.S. RETAINER>(*1.2.3)
31. N.S. O-RING>(*1.2.3)
32. N.S. ROD ASM, AIR VALVE(*1.3)
33. N.S. PISTON, POWER(*1.5)

NOTE 1 GROUP 4 901 SERVICE POWER BOOSTER (INCLS #1 THRU 33)

NOTE 2 GROUP 4 898 REPAIR KIT, PWR BOOSTER (INCLS #1 THRU 8.14.15.16.18.20.22.27 28.29.30)

NOTE 3 GROUP 4 918 VALVE KIT, AIR (INCLS #2.24.26 THRU 32)

NOTE 4 GROUP 4 955 VALVE KIT, W/GROMMET (INCLS #3.4)

NOTE 5 GROUP 4 922 PISTON KIT. (INCLS #22 THRU 25.33)

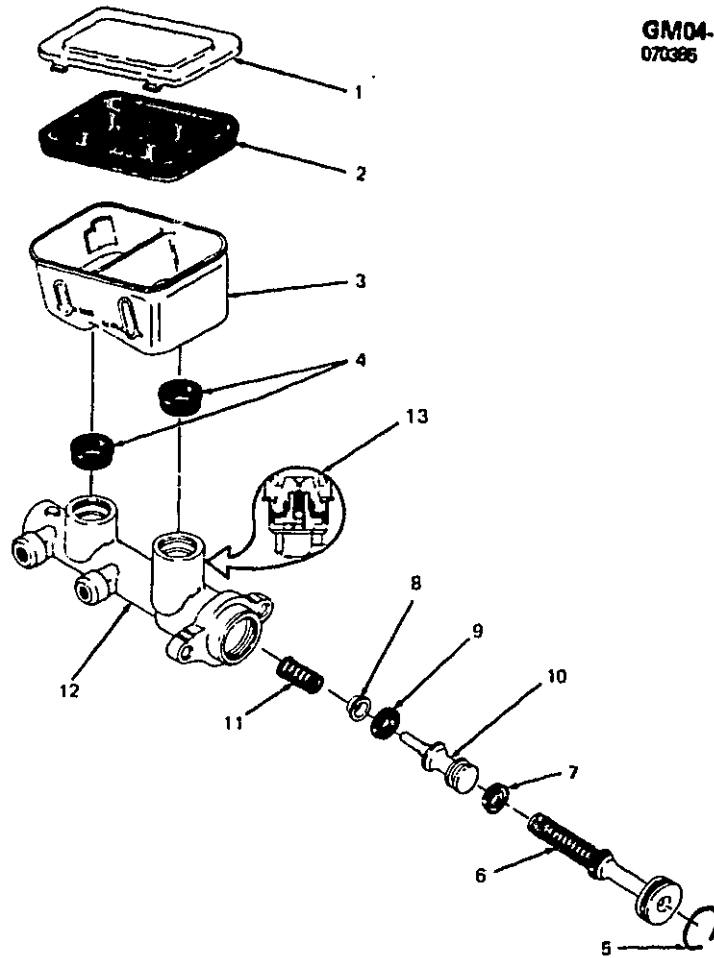

DM3150G050

GM04-203

1985-1988 P BRAKE MASTER CYLINDER (MORAINE)

NOTE SEE CHART IN GROUP FOR USAGE

1.	D26	4.651	COVER, M/CYL RESVR(*1)
2.	D26	4.651	DIAPHRAGM KIT, M/CYL RESVR(*1)
3.		N.S.	RESERVOIR, M/CYL(*1,3)
4.		N.S.	GROMMET, M/CYL RESVR(*1,3)
5.		N.S.	RING, LOCK(*1,2)
6.		N.S.	PISTON, PRIMARY(*1,2)
7.		N.S.	SEAL, SECONDARY(*1,2)
8.		N.S.	RETAINER, SEC PISTON SPRING(*1,2)
9.		N.S.	SEAL, PRIMARY(*1,2)
10.	D26	4.653	PISTON, M/CYL SECD(*1)
11.		N.S.	SPRING, SECD PISTON(*1)
12.		N.S.	BODY, M/CYL(*1)
13.		N.S.	QUICK TAKE UP

NOTE 1 SERVICE MASTER CYLINDER. GROUP 4.650 (INCLS #1 THRU 12)

NOTE 2 REPAIR KIT. GROUP 4 649 (INCLS #5,6,7,8,9)

NOTE 3 RESERVOIR & GROMMET KIT. GROUP 4.651 (INCLS #3,4)

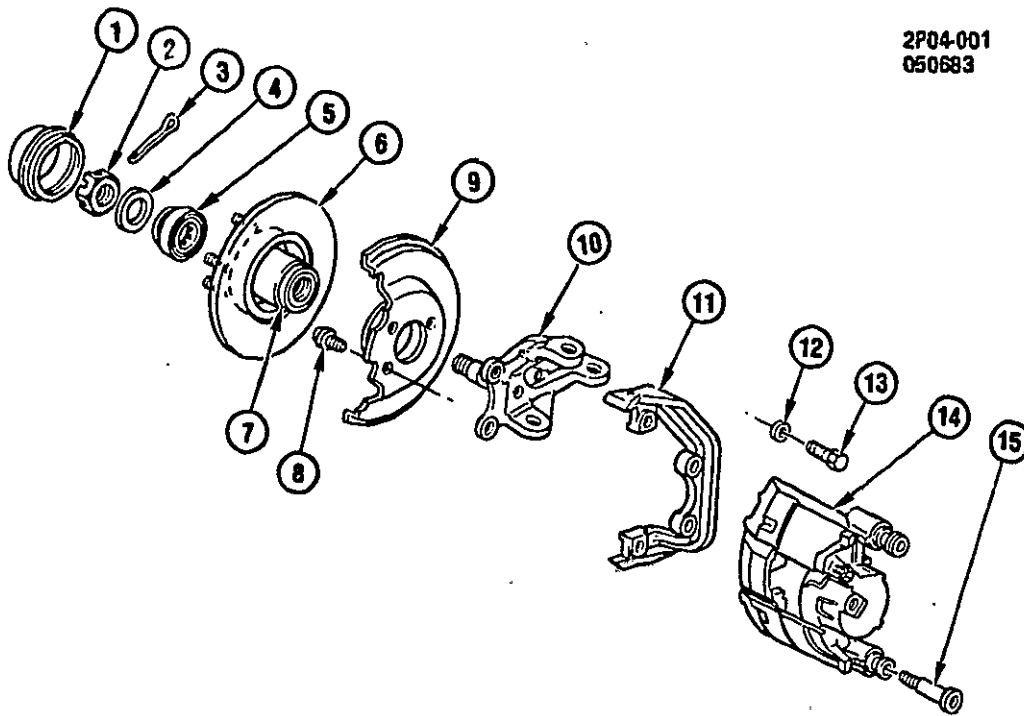

2P04-001

1984-1987 P BRAKE CALIPER/FRONT DISC

1.	N23	6.330	CAP, FRT WHL BEARING GREASE	6255554
2.	N23	6.022	NUT, STRG KNU SPDL	361745
3.		8.938	PIN, COTTER (3.2 X 25M)	
4.	N23	6.321	WASHER, STRG KNU SPDL	361740
5.	N23	6.313	BEARING, FRT WHL OTR	9415135
6.	E16	5.809	ROTOR, BRK-W/HUB	10039013
7.	N23	6.311	BEARING, INPUT GR	9415132
8.		8.900	BOLT, HEX W/CON WA (M6 X 1 X 13)	
9.	E9	5.002	SHIELD, SPLASH	10032502
10.	N23	6.020	KNUCKLE, STRG-RH	14001236
	N23	6.020	KNUCKLE, STRG-LH	14001235
11.	E9	5.001	BRACKET, CLPR MT-RH	18012302
	E9	5.001	BRACKET, CLPR MT-LH	18012301
12.		8.931	WASHER, MED SPR LOCK (7/16")	
13.	D26	4.665	BOLT, MTG BRKT TO STRG KNU	471109
14.	D26	4.665	CALIPER, BRK-RH (1984)	18011294
	D26	4.665	CALIPER, BRK-LH (1984)	18011293
	D26	4.665	CALIPER, BRK-RH (1985-87)	18012366
	D26	4.665	CALIPER, BRK-LH (1985-87)	18012365
	D26	4.668	PISTON, CLPR	18010264
	D26	4.667	REPAIR KIT, CLPR	18011295
	D26	4.666	COVER, CLPR BOLT	18009829
	D26	4.666	VALVE, CALIPER BLEEDER	18013395
	E9	5.017	PAD KIT, DISC	12300237
15.	D26	4.665	BOLT, CLPR-W/SLEEVE	18016163
	D26	4.665	BUSHING, CLPR BOLT	18001032

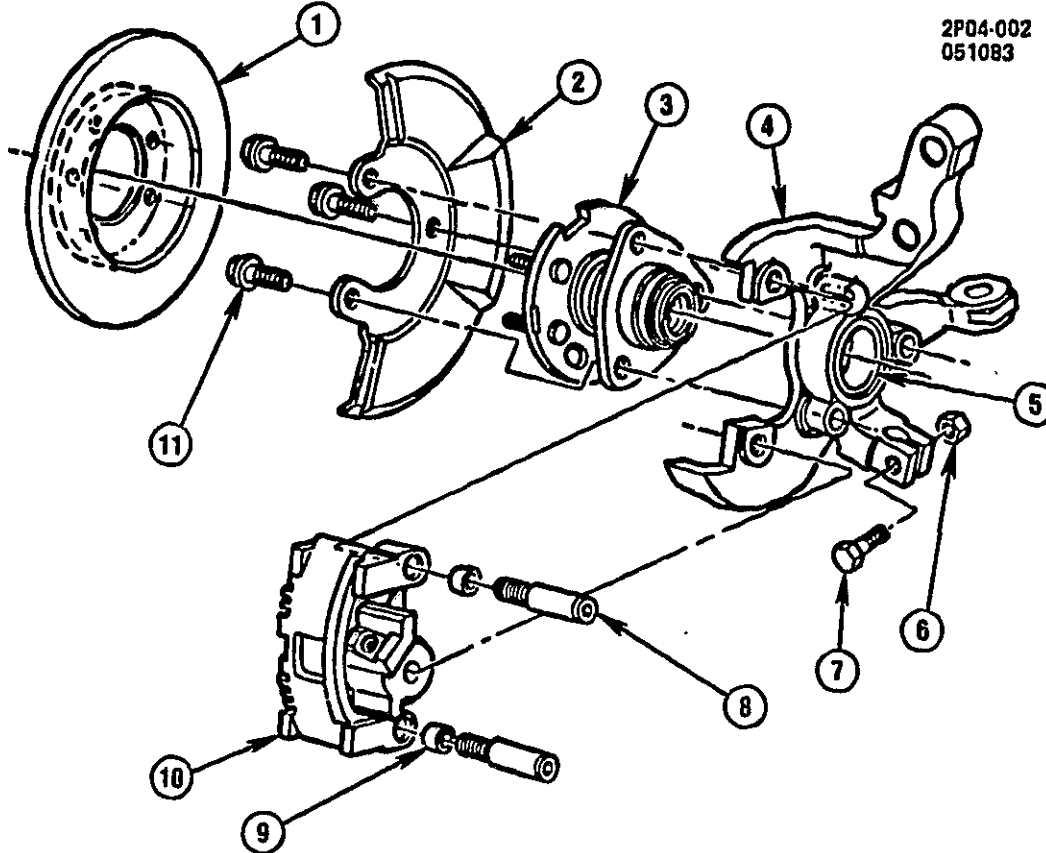

2P04-002

1984-1987 P BRAKE CALIPER/REAR DISC

1.	E16	5.809	ROTOR, RR BRK	10022442
2.	E9	5.002	SHIELD, DISK BRK SPLASH	10031892
3.	E16	5.855	HUB KIT, SUSP (6.307)	7470002
4.	E16	5.806	KNUCKLE, SUSP-RH (6.020)	14076994
	E16	5.806	KNUCKLE, SUSP-LH (6.020)	14076993
5.	E9	5.002	SEAL KIT, KNUCKLE (6.326)	14084120
6.		8.917	NUT, HWH TORX PREV (M10 X 1.5)	
7.	E16	5.808	BOLT, RR SUSP KNU (6.104)	14089585
8.	D26	4.665	BOLT, CLPR-W/SLEEVE	18016163
	D26	4.665	COVER, CLPR BOLT	18009829
9.	D26	4.665	BUSHING, CLPR BOLT	18001032
10.	D26	4.665	CALIPER, RR-RH	18014437
	D26	4.665	CALIPER, RR-LH	18014436
	D26	4.667	REPAIR KIT, CLPR	18011329
	D26	4.665	SCREW, CLPR ACTR-RH	18006297
	D26	4.665	SCREW, CLPR ACTR-LH	18005296
11.		8.900	SCREW, HEX (M12 X 1.75 X 40)	

GM04-251
051586

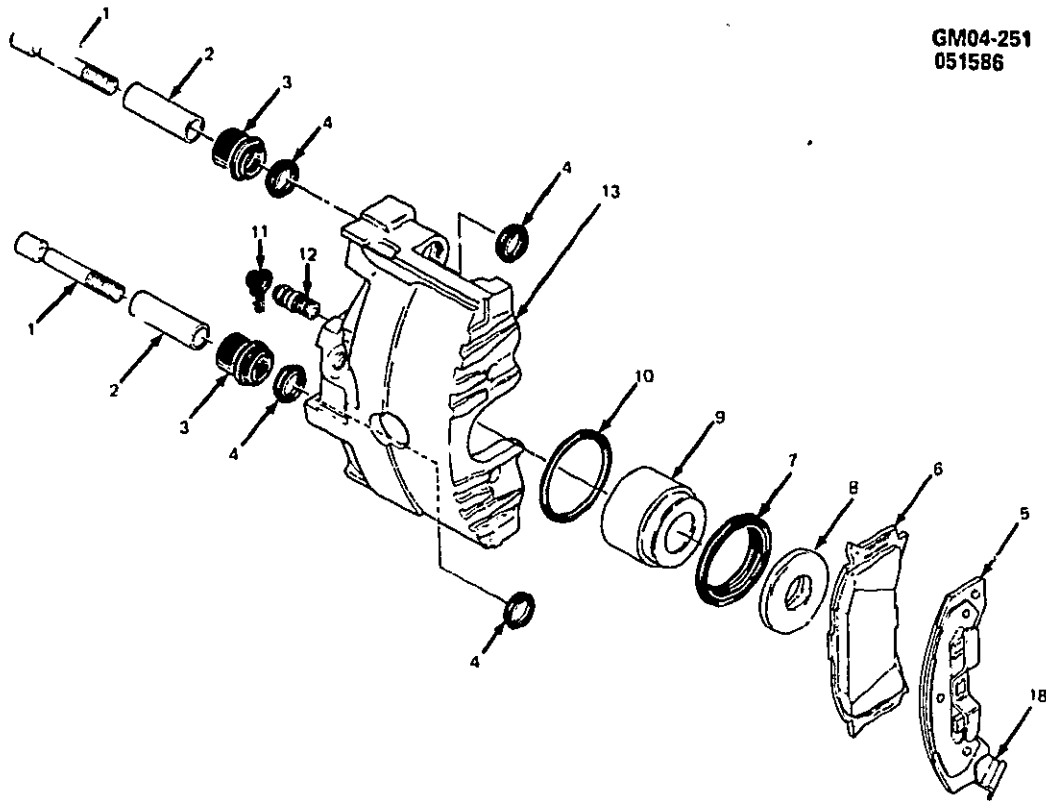

DM3165C154

GM04-251

1986-1987 P BRAKE CALIPER/FRONT DISC (5349 SERIES)(MORaine)

1.	N.S.	BOLT, MOUNTING. (2 REQD)(*3)
2.	N.S.	SLEEVE, MTG BOLT (2 REQD)(*3)
3.	D26	4.665 COVER, CLPR BOLT (2 REQD)
4.	D26	4.665 BUSHING, CLPR BOLT (4 REQD)(*1.5)
5.	N.S.	SHOE & LINING, OUTBOARD(*5)
6.	N.S.	SHOE & LINING, INBOARD(*5)
7.	N.S.	BOOT, PISTON(*1.2)
8.	N.S.	PROTECTOR, PISTON(*4)
9.	N.S.	PISTON(*1.4)
10.	N.S.	SEAL, PISTON(*1.2)
11.	N.S.	CAP, BLEEDER VLV(*1)
12.	D26	4.666 VALVE, CALIPER BLEEDER(*1)
13.	N.S.	HOUSING, CALIPER(*1)
18.	N.S.	SENSOR, WEAR(*5)

- NOTE 1 GROUP 4.665 CALIPER, FRT BRK (INCLS #4.7.9.10.11.12.13)
NOTE 2 GROUP 4.667 REPAIR KIT, FRT CALIPER PISTON (INCLS #7,10)
NOTE 3 GROUP 4.665 BOLT, W/SLEEVE, FRT BRK CLPR (INCLS #1.2)
NOTE 4 GROUP 4.668 PISTON, FRT BRK CALIPER (INCLS #8,9)
NOTE 5 GROUP 5.017 PAD KIT, FRT DISC BRK (INCLS #4.5.6.18)

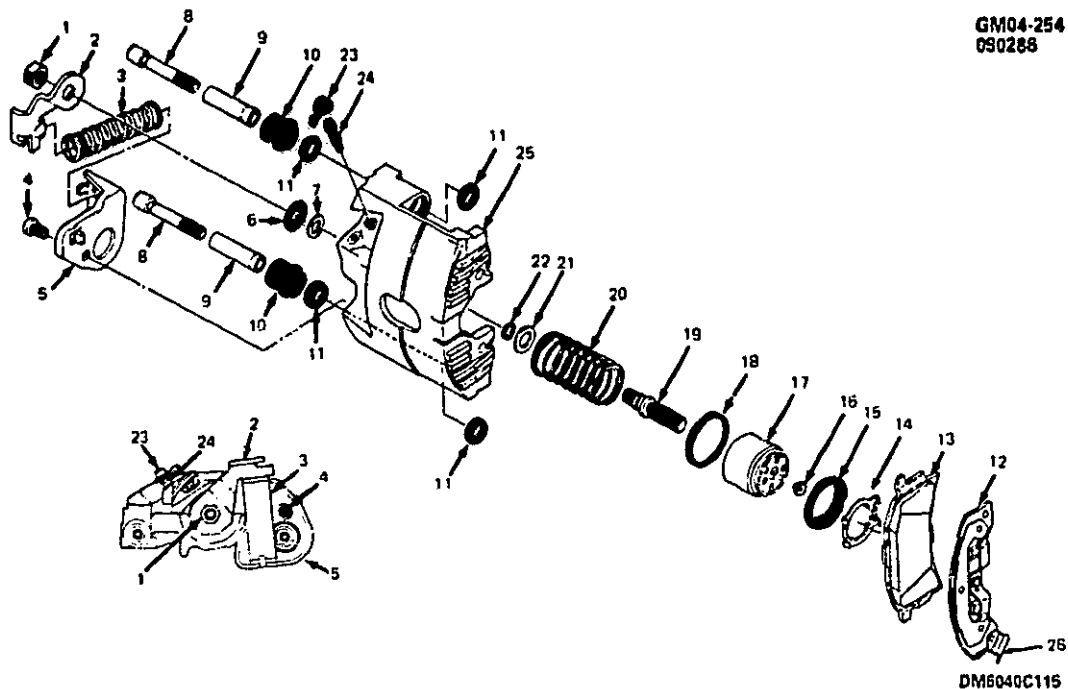

DM6040C115

GM04-254

1986-1987 P BRAKE CALIPER/REAR DISC (5748 SERIES)(MORAINE)

1.	N.S.	NUT, ACTUATOR(*1 5)
2.	E9	LEVER, PK BRK(*1)
3.	E9	SPRING, LVR RETURN(*1)
4.	N.S.	BOLT, BRKT(*1 6)
5.	N.S.	BRACKET, PK BRK CBL(*1 6)
6.	N.S.	SEAL, LEVER(*1 2.7)
7.	N.S.	WASHER, ANTI-FRICTION(*1 2 7)
8.	N.S.	BOLT, MTG(*3)
9.	N.S.	SLEEVE, BOLT MTG(*3)
10.	D26	4.665 COVER, CLPR BOLT (2 REOD)
11.	D26	4.665 BUSHING, BOLT (4 REOD)(*1.7)
12.	N.S.	SHOE & LINING, OUTBOARD(*7)
13.	N.S.	SHOE & LINING, INBOARD(*7)
14.	D26	4.669 SPRING KIT, DISC PAD
15.	N.S.	BOOT, PISTON(*1.2)
16.	N.S.	VALVE, TWO-WAY CHECK(*1.2.4.7)
17.	N.S.	PISTON(*1.4)
18.	N.S.	SEAL, PISTON(*1.2.4)
19.	N.S.	SCREW, ACTUATOR(*1 5)
20.	N.S.	SPRING, BALANCE(*1)
21.	N.S.	WASHER, THRU(*1.2)
22.	N.S.	SEAL, SHAFT(*1.2)
23.	N.S.	CAP, BLEEDER VLV(*1)
24.	D26	4.666 VALVE, CLPR BLEEDER(*1)
25.	N.S.	HOUSING, CALIPER(*1)
26.	N.S.	SENSOR, WEAR(*7)

NOTE 1 GROUP 4 665 CALIPER RR BRK (INCLS #1 THRU 7.11 15 THRU 25)
 NOTE 2 GROUP 4 667 REPAIR KIT RR BRK CLPR (INCLS #6.7.15.16.18 21.22)
 NOTE 3 GROUP 4 665 BOLT W/SLEEVE RR CLPR (INCLS #8.9)
 NOTE 4 GROUP 4 668 PISTON, W/ACTR. RR BRK CLPR (INCLS #6.17.18)
 NOTE 5 GROUP 4 665 SCREW W/LK NUT RR BRK CLPR ACTR (INCLS 1 19)
 NOTE 6 GROUP 5 158 BRACKET W/BOLT. RR CLPR PK BRK CBL (INCLS #4.5)
 NOTE 7 GROUP 5 017 PAD KIT RR DISC BRK (INCLS #6.7.11.12.13.16.26)

GM04-276
040687

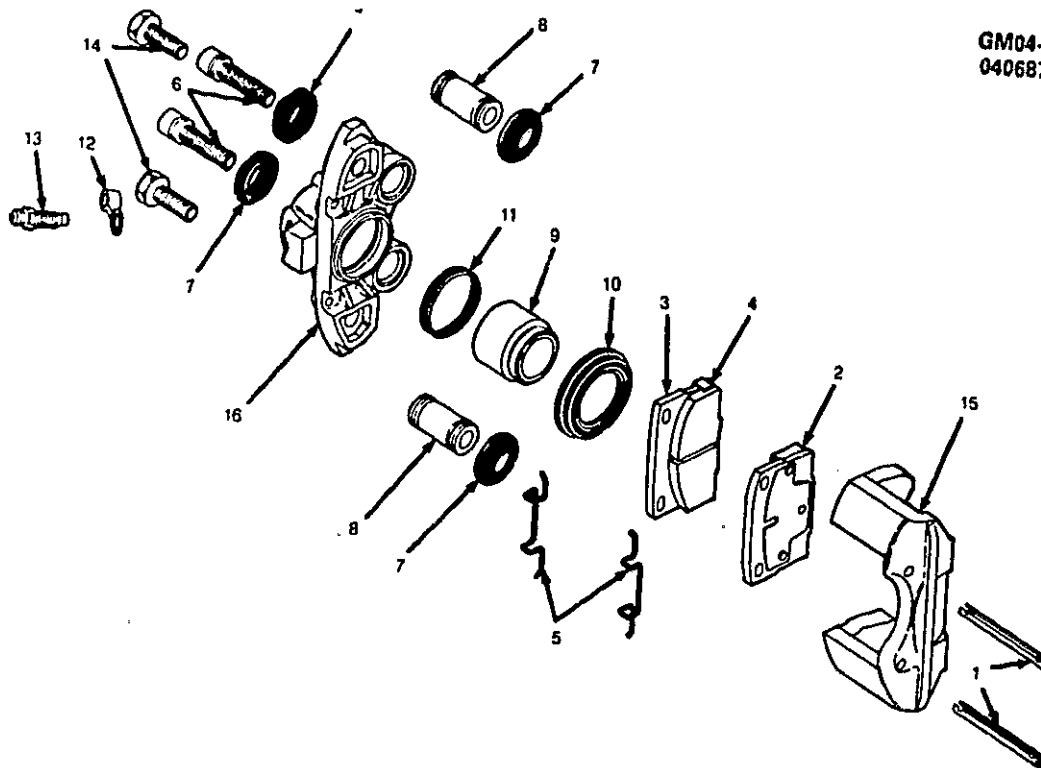

DM6253C306

GM04-276

1988 P BRAKE CALIPER/FRONT DISC (48H SERIES)(MORaine)

NOTE SEE BRAKE CHART AT THE END OF 4 000 GROUP

1.	N.S.	PIN, SPRING(*4.5)
2.	N.S.	SHOE & LINING, OUTBOARD(*5)
3.	N.S.	SHOE & LINING, INBOARD(*5)
4.	N.S.	SENSOR, WEAR(*5)
5.	N.S.	SPRING, (2 REQD)(*4.5)
6.	D26	4.665 BOLT, MOUNTING (2 REQD)
7.	N.S.	BOOT, SLEEVE(2 REQD)(*1.3)
8.	N.S.	SLEEVE, (2 REQD)(*1.3)
9.	D26	4.668 PISTON>(*1)
10.	N.S.	BOOT>(*1.2)
11.	N.S.	SEAL, PISTON(*1.2)
12.	N.S.	CAP, BLEEDER VALVE(*1)
13.	D26	4.666 VALVE, BLEEDER(*1)
14.	D26	4.665 BOLT, BRIDGE (2 REQD)(*1)
15.	N.S.	BRIDGE(*1)
16.	N.S.	HOUSING, CALIPER(*1)

NOTE 1 GROUP 4 665 CALIPER, FRT BRK (INCLS #7 THRU 16)

NOTE 2 GROUP 4 667 REPAIR KIT, FRT CALIPER (INCLS #10.11)

NOTE 3 GROUP 4 665 SLEEVE & BOOT KIT FRT BRK CALIPER (INCLS #7.8)

NOTE 4 GROUP 4 665 PIN & SPRING KIT FRT BRK CALIPER SHOE (INCLS #1 5)

NOTE 5 PAD KIT FRT DISC BRK (INCLS #1 THRU 5)

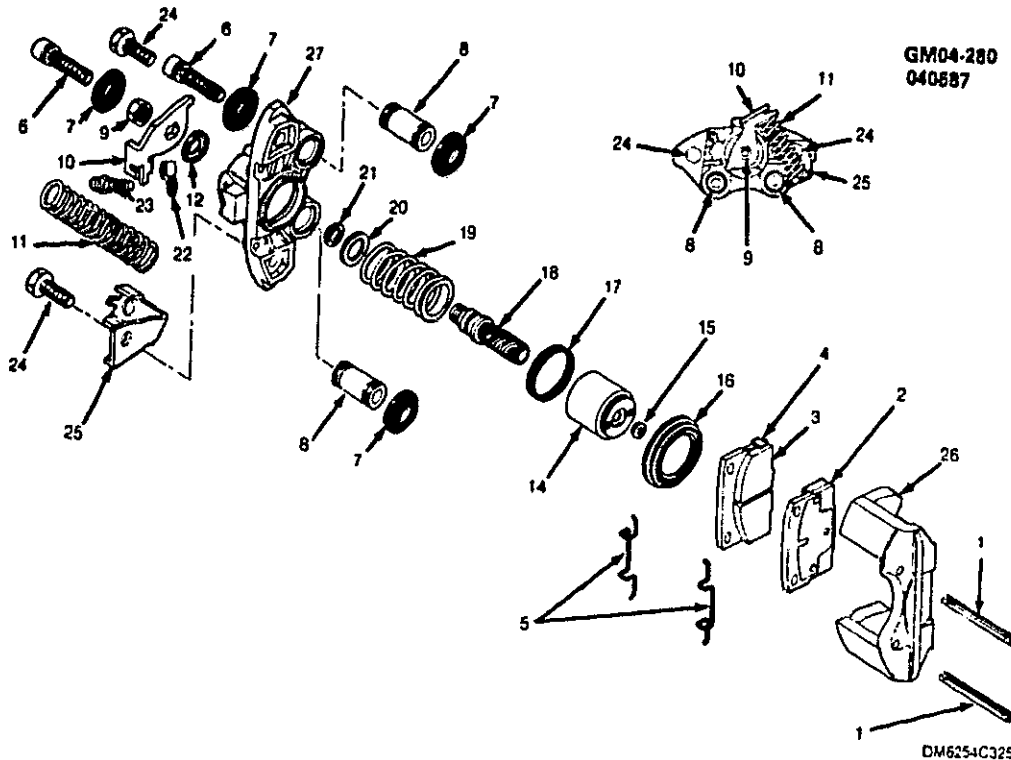

GM04-280

1988 P BRAKE CALIPER/REAR DISC (48H SERIES)(MORAINE)

1.	N.S.	PIN, SPRING (2 REQD)(* 4 7)
2.	N.S.	SHOE & LINING, OUTBOARD(* 7)
3.	N.S.	SHOE & LINING, INBOARD(* 7)
4.	N.S.	SENSOR, WEAR(* 7)
5.	N.S.	SPRING>(* 4 7)
6.	D26	4.665 BOLT, MOUNTING (2 REQD)
7.	N.S.	BOOT, SLEEVE (2 REQD)(* 1 3)
8.	N.S.	SLEEVE, (2 REQD)(* 1 3)
9.	N.S.	NUT>(* 1 6)
10.	E9	5.149 LEVER(* 1)
11.	E9	5.151 SPRING, RETURN(* 1)
12.	N.S.	SEAL, LEVER(* 1 2 7)
14.	N.S.	PISTON>(* 1 5)
15.	N.S.	VALVE, TWO WAY CHECK(* 1 2 5 7)
16.	N.S.	BOOT>(* 1 2)
17.	N.S.	SEAL, PISTON(* 1 2)
18.	N.S.	SCREW, ACTUATOR(* 1 6)
19.	N.S.	SPRING, BALANCE(* 1)
20.	N.S.	WASHER, THRUST(* 1 2)
21.	N.S.	SEAL, SHAFT(* 1 2)
22.	N.S.	CAP, BLEEDER VALVE(* 1)
23.	D26	4.666 VALVE, BLEEDER(* 1)
24.	D26	4.665 BOLT, BRIDGE(* 1)
25.	E9	5.001 BRACKET(* 1)
26.	N.S.	BRIDGE(* 1)
27.	N.S.	HOUSING, CALIPER(* 1)

NOTE 1 GROUP 4 665 CALIPER RR BRK (INCLS # 7 THRU 12 14 THRU 27)

NOTE 2 GROUP 4 667 REPAIR KIT RR BRK CLPR (INCLS # 12, 15 16 17 20 21)

NOTE 3 GROUP 4 665 BOOT KIT RR CLPR SLEEVE (INCLS # 7 8)

NOTE 4 GROUP 4 665 SPRING W/SHOE PIN RR CLPR (INCLS # 1 5)

NOTE 5 GROUP 4 665 PISTON CLPR ACTR (INCLS # 14 15)

NOTE 6 GROUP 4 665 SCREW W/NUT CLPR ACTR (INCLS # 9 18)

NOTE 7 GROUP 5 017 PAD KIT RR DISC BRK (INCLS # 1 THRU 5 12 15)

2P04-004
020484

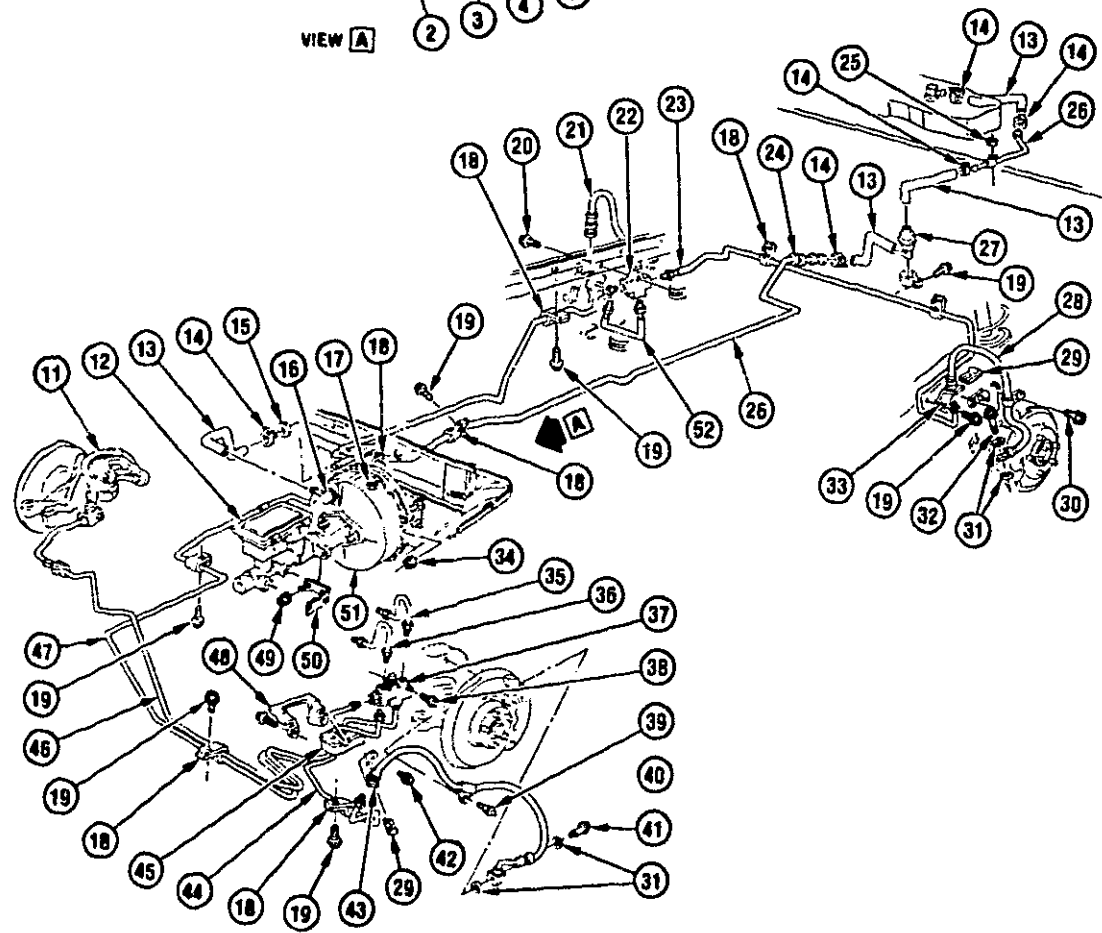
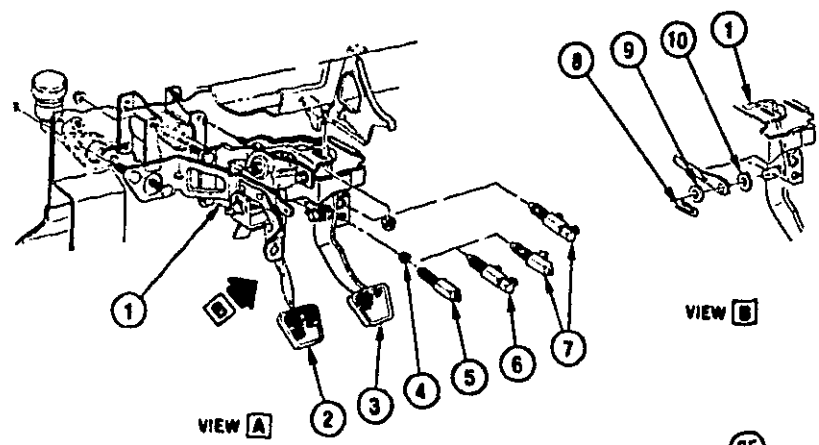

1984-1985 P BRAKE PEDAL & MASTER CYLINDER MOUNTING

1.	N.S.	PEDAL, BRAKE PEDAL & SUPT-SEE GROUP 0 000 EXPLODE	
2.	D23	4.630 COVER, CLU PED PAD	14009148
3.	D23	4.630 COVER, BRK PED-W/M T	14009148
	D23	4.630 COVER, BRK PED-W/A T	1256203
4.	N21	2.447 RETAINER, STOP LP SW	22534155
5.	N21	2.447 SWITCH, STOP LP-W/M T (1985 EXC K34)	25524844
6.	N21	2.447 SWITCH, STOP LP-W/A T (EXC K34)	25524848
7.	N21	2.447 SWITCH, STOP LP (1984-85 W/K34)	25524845
8.		8.934 RETAINER, TYPE B (.062 SPR STL WIRE)	
9.		8.929 WASHER, FLAT (3/4"X13/32"X1/16")	
10.		8.928 WASHER, SPR (11/16"X15/32"X1/16")	
11.	D27	4.680 HOSE, FRT BRK-RH (1984)	17981515
	D27	4.680 HOSE, FRT BRK-RH (1985)	17981448
12.	D23	4.650 CYLINDER, MASTER	18014285
13.		8.982 HOSE, (11/32" X 25FT)(*2)	
14.		8.948 CLAMP, WORM GEAR (62 TO 1 25)	12337891
15.	D28	4.845 GROMMET, P/B BOOS TUBE	10024270
16.	E3	4.956 VALVE, PWR BOOS-W/GROMMET	18003614
17.		8.915 NUT, HEX (M6 X 1)	
18.	D28	4.845 CLIP, BRK PIPE (3 162)	22518924
19.		8.977 SCREW, HWH TAP (M6 3 X 1 81 X 16)	
20.		8.900 SCREW, HFH (M6 X 1 X 20)	
21.	D27	4.680 HOSE, RR BRK-RH	17982498
22.	E3	4.931 FITTING, RR BRK FRT PIPE	10024443
23.	N.S.	PIPE, RR BRK RR(*1)	
24.	D28	4.845 GROMMET, P/B BOOS TUBE-RR	10040114
25.		8.915 NUT, HEX (M10 X 1.5)	
26.	N.S.	TUBE, P/B BOOS(*3)	
27.	E3	4.913 FILTER, PWR BRK BOOS (1984)	17070814
	E3	4.913 FILTER, PWR BRK BOOS (1985)	17085016
28.	D27	4.680 HOSE, RR BRK-LH	17982499
29.	D27	4.681 RETAINER, FRT OR RR BRK HOSE	22527167
30.		8.900 BOLT, HEX (M8X1 25X13)	
31.		8.929 WASHER, FL COPPER (M10 3X17X1 30)	
32.	D27	4.686 BOLT, RR BRK HOSE (M10X1 5)	14094948
33.	D27	4.686 BRACKET, RR BRK HOSE-RH	10024193
	D27	4.686 BRACKET, RR BRK HOSE-LH	10024194
34.		8.917 NUT, HEX(M8X1 25)	
35.	N.S.	PIPE, RR BRK COMB VLV(*4)	
36.	N.S.	PIPE, FRT BRK M/C TO COMB VLV(*4)	
37.	D27	4.690 VALVE, BRK COMB (1984 EXC Y82)	10028021
	D27	4.690 VALVE, BRK COMB (1984 Y82)	10038563
	D27	4.690 VALVE, BRK COMB (1985)	10038563
38.		8.977 SCREW, HWH TAP (M6 3X1 81X35)	
39.		8.967 RIVET, MONO BOLT (1/4" DIA)	
40.	D27	4.680 HOSE, FRT BRK-LH (1984)	17981516
	D27	4.680 HOSE, FRT BRK-LH (1985)	17981449
41.	D27	4.686 BOLT, FRT BRK HOSE (M10X1 5)	14094948
42.		8.977 SCREW, HWH TAP (M6 3X 81X16)	
43.	D27	4.686 BRACKET, FRT BRK HOSE SUPT-RH (1984)	10031347
	N.S.	BRACKET, FRT BRK HOSE SUPT-LH (1984)	
44.	N.S.	PIPE, FRT BRK(*5)	
45.	D27	4.685 INSULATOR, FRT BRK PIPE	10024395
46.	N.S.	PIPE, FRT BRK(*5)	
47.	D27	4.686 PIPE, RR BRK INTER	10036433
48.	D27	4.681 BRACKET, FRT BRK HOSE	10024445
		8.977 SCREW, HWH TAP (M6 3X 81X16)	
49.		8.917 NUT, TORX PREV HWH (M10 X 1 5)	
50.	D27	4.690 BRACKET, COMB VLV TO M/CYL	10028622
51.	D28	4.901 BOOSTER, VAC P/B	18010350
52.	N.S.	PIPE, RR BRK RR(*5)	

NOTE 1 USE 8 964.3696822 TUBING (3/16"X 25FT) 8 964.3793113 ARMOR SHELDDING. 8 963.11504479 NUT

NOTE 2 CUT TO LENGTH

NOTE 3 USE 8 964.3750950 TUBING (3/8" X 25FT)

NOTE 4 USE 8 964.3696822 TUBING (3/16" X 25FT). 8 963.9424955 NUT. 8 963.9424958 NUT

NOTE 5 USE 8 963.11504479 NUT & 8 964.3696822 TUBING (3/16"X 25FT)

2P04-014
081286

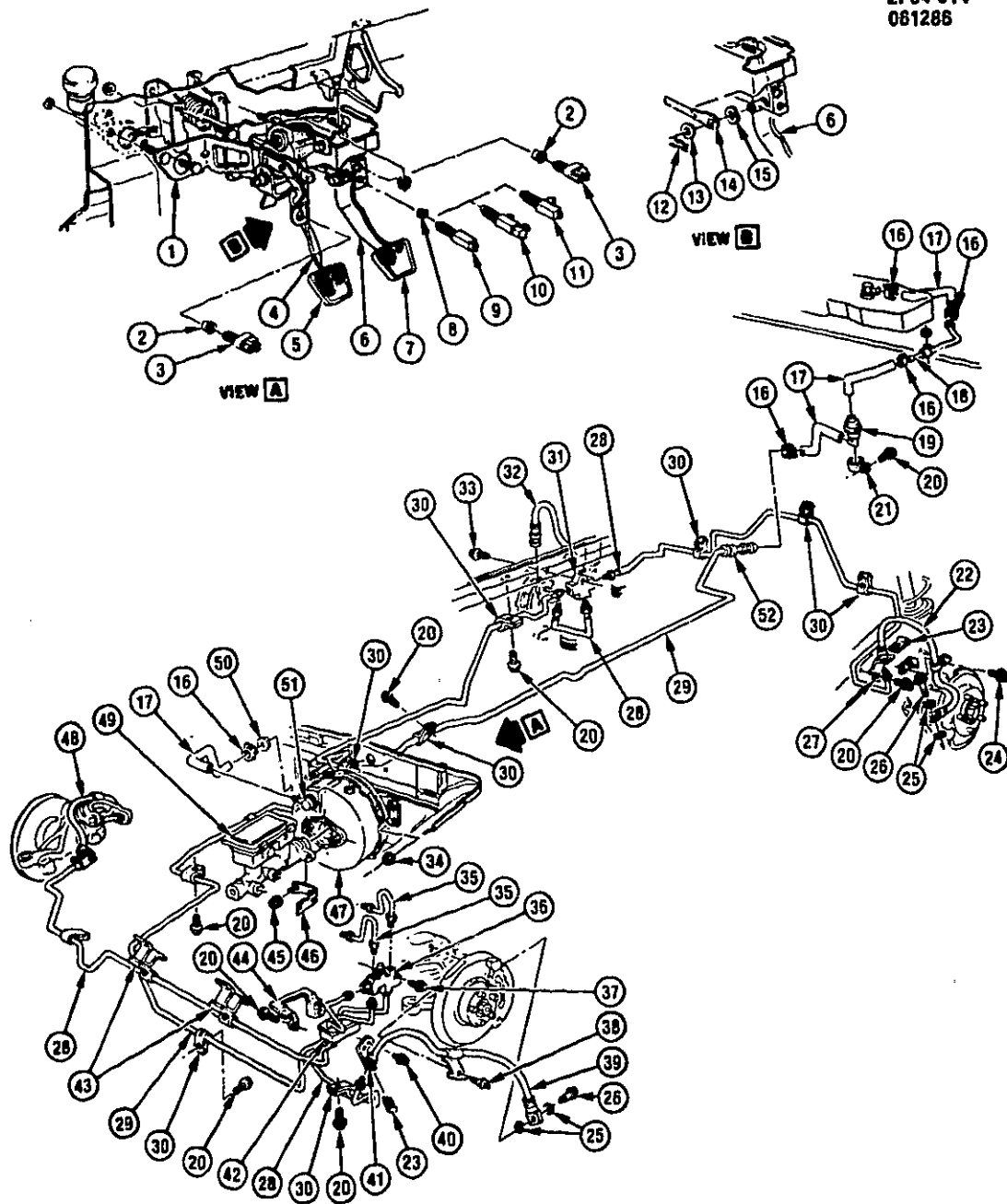

2P04-014

1986-1988 P BRAKE PEDAL & MASTER CYLINDER MOUNTING

1.	N14	0.829	SUPPORT, CLU PED (1986 MT2.M17K*2)	10038579
	N14	0.829	SUPPORT, CLU PED (1986 MT2.M17K*3)	14105679
	N14	0.829	SUPPORT, CLU PED (MG2)	14105679
	N14	0.829	SUPPORT, CLU PED (1987 MT2.M17)	14105679
2.	B8	3.865	RETAINER, CRCONT VAC REL VLV	1612303
3.	B8	3.863	SWITCH, BRK & CLU VAC REL-W/K34)	10024217
4.		N.S.	PEDAL, CLU (1986 MT2.M17K*2)	
	N14	0.830	PEDAL, CLU (1986 W/MT2.M17K2ND DESK*3)	10086423
	N14	0.830	PEDAL, CLU (1986 W/MT2.M17K2ND DES)	10086423
	N14	0.830	PEDAL, CLU (1986 W/MT2.M17K2ND DES)	10086423
	N14	0.831	BUSHING, CLU PED	15594358
5.	D23	4.630	COVER, CLU PED PAD	14009148
6.	D23	4.625	PEDAL, BRK-W/M T (1986-87)	10137317
	D23	4.625	PEDAL, BRK-W/A T (1986-87)	10137315
	D23	4.625	PEDAL, BRK-W/M T (1988)	10047605
	D23	4.625	PEDAL, BRK-W/A T (1988)	10047602
	D23	4.626	BUSHING, BRK PED (0 831)	15594358
7.	D23	4.630	COVER, BRK PED PAD-W/M T	14009148
8.	N21	2.447	RETAINER, STOP LP SW	22534155
9.	N21	2.447	SWITCH, STOP LP-W/M T (EXC K34)(1986-88,	25529882
10.	N21	2.447	SWITCH, STOP LP-W/MD9 (EXC K34)	25529861
11.	N21	2.447	SWITCH, STOP LP-W/K34	25529860
12.		8.934	RETAINER, TYPE B (062 SPR STL WIR)	10040797
13.		8.929	WASHER, (441 X 750X 060) PH	492346
14.		N.S.	ROD, PUSH	
15.		8.928	WASHER, SPR (29/64"X11/16"X5/64")	410230
16.	N18	1.168	CLAMP, WORM TYPE (.56"TO 1.06"DIA)	22518685
17.		8.962	HOSE, VAC BRK SYS (11/32"X25"K*1)	9438124
18.	E3	4.931	TUBE, PWR BOOS RR-W/LR8 (1986)	10029223
	E3	4.931	TUBE, PWR BOOS RR-W/LR8 (1987-88)	14102348
19.	E3	4.913	FILTER, PWR BRK BOOS (1986)	17085018
20.		8.977	BOLT, SEMS HWH (M6 3X1 81X20 AB)	22527475
21.	E3	4.913	BRACKET, PWR BRK BOOS FI TR	10024272
22.	D27	4.680	HOSE, RR BRK-LH	17982499
23.	D27	4.681	RETAINER, FRT OR RR BRK HOSE	22527187
24.		8.900	BOLT, HEX (M8X1 25X16) 9 8 PS	11509589
25.	D27	4.671	WASHER, FL-C R COPPER (M10 3X17X1 30)	14000172
26.	D27	4.688	BOLT, BRK HOSE (M10 X 1 5)	14094948
27.	D27	4.688	BRACKET, RR BRK HOSE-RH (1986-87)	10024193
	D27	4.688	BRACKET, RR BRK HOSE-LH (1986-87)	10024194
	D27	4.681	BRACKET, FRT OR RR HOSE-RH (1988)	10047650
	D27	4.681	BRACKET, FRT OR RR HOSE-LH (1988)	10047649
28.		8.964	TUBING, BLK (3/16"X25FT STLK*1)	3696822
		8.964	ARMOR SHIELDING, BRK PIPE (3/16"ID X 4FTK*1)	3793113
		8.963	NUT, FLARED TUBE (M10X1 TRD ZD)	11504479
29.	D27	4.686	PIPE, RR BRK CTR FRT	10036433
30.		8.950	CLIP, CLSD TYPE 4/TANG (1/4" OR 5/16" PIPEX17/32"X1/2")	343464
31.	E3	4.931	FITTING, RR BRK FRT PIPE	10024443
32.	D27	4.680	HOSE, RR BRK-RH (1986-87)	17982498
	D27	4.680	HOSE, RR BRK-RH (1988)	17989352
33.		8.900	BOLT, HFH (M6X1X20)9 8 PZOR	11508600
34.		8.917	NUT, HEX TORQ PREV (M8X1 25) 10 CAD	11500760
35.		8.964	TUBING, STL BRAKES (1/4"K*1)	603827
		8.963	NUT (1/4" INVERTED FLARED TUBE)ZD	9424955
	D27	4.681	NUT, FRT BRK COMB VLV PIPE	25519423
36.	D27	4.690	VALVE, BRK COMB (1986-87)(2 5R)	10036563
	D27	4.690	VALVE, BRK COMB (1988)	10071501
37.		8.900	BOLT, HEX W/CON SPR WA (M6X1X30)(TYPE B)9 8 POR	11505209
38.	D27	4.686	RIVET, MONO BOLT (1/4"DIA-.08X 32GRIP RA)	
39.	D27	4.680	HOSE, FRT BRK-LH (1986-87)	17981449
	D27	4.680	HOSE, FRT BRK-LH (1988)	17986231
40.		8.977	SCREW, HWH TAP (M6 3X1 81X13) PZOR	11508797
41.	D27	4.681	BRACKET, FRT BRK HOSE SUPT-LH (1986-87)	10036291
	D27	4.681	BRACKET, FRT BRK HOSE SUPT RH (1986 87)	10038293
	D27	4.681	BRACKET, FRT & RR BRK HOSE LH (1988)	10047649
	D27	4.681	BRACKET, FRT & RR BRK HOSE-RH (1988)	10047650
42.	D27	4.685	INSULATOR, FRT BRK PIPE	10024395
43.		N.S.	CLIP, TUBE	
		8.965	RETAINER, PLASTIC 7" ADJ STRAP	3816859
44.	D27	4.681	BRACKET, FRT BRK HOSE	10024445
45.		8.917	NUT, HWH (M10X1 5)10 CAD	11502812
46.	D27	4.690	BRACKET, COMB VLV TO M/CYL	10028822
47.	D28	4.901	BOOSTER, P B (1986)(4)	18010390

47.	D28	4.901	BOOSTER, P B (1987)*4)	18013153
	D28	4.901	BOOSTER, P B (1988)	18014641
48.	D27	4.680	HOSE, FRT BRK RH	17981448
49.	D23	4.650	CYLINDER, MASTER (1986 87)*4)	18014285
	D23	4.650	CYLINDER, MASTER (1988)*4)	18014838
	D28	4.651	COVER, M CYL RESVR	18008073
50.	D28	4.845	GROMMET, VAC TUBE FRT (1986)	10024270
	D28	4.845	GROMMET, VAC TUBE FRT (1987-88)	14102351
51.	E3	4.955	VALVE, VAC CHK-W/GROMMET	18003614
52.	D28	4.845	GROMMET, P B BOOS TUBE RR CTR	10040114

NOTE 1 CUT TO SIZE

NOTE 2 1986 1ST DESIGN ALUM CLUTCH PEDAL & PEDAL RETURN SPRING

NOTE 3 1986 2ND DESIGN STEEL CLUTCH PEDAL & NO RETURN SPRING

NOTE 4 COMPONENT PARTS SERVICED SEPARATELY

2P04-003
021585

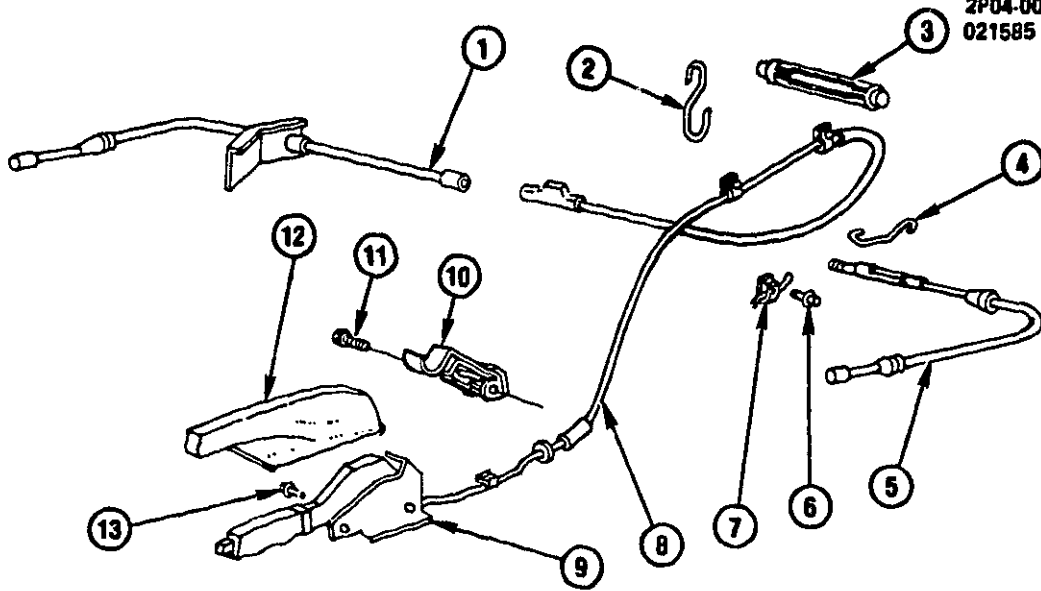

2P04-003

1984-1987 P PARKING BRAKE SYSTEM

1.	D27	4.779	CABLE, RR-RH	10055394
2.	D28	4.785	CLIP, RR CBL AT CRADLE C/MBR	10028861
3.	D27	4.766	EQUALIZER, PARK BRK CBL	25612384
4.	D28	4.785	CLIP, FRT CBL TO FRM	10034190
5.	D27	4.779	CABLE, RR-LH	10055393
6.		8.977	BOLT, HWH TAP (M6 3X1 81X16)	12337828
7.	D27	4.779	CLIP, CLSD (560)	10038834
8.	D27	4.779	CABLE, PK BRK FRT	10055395
9.	D23	4.591	LEVER	10046473
10.	D23	4.589	SWITCH, PK BRK IND	10026235
11.		8.900	BOLT, HWD TAP (M4 2Y1 41X25) ZC	11504591
12.	D23	4.612	BOOT, PK BRK (GRAPHITE GRAY)(131)(1984-85)	10031779
	D23	4.612	BOOT, PK BRK (MED DK DOESKIN)(64)(1984-85)	10031778
	D23	4.612	BOOT, PARK BRK LVP (GRAPHITE GRAY)(1986-87)	10042213
	D23	4.612	BOOT, PARK BRK LEVER (DK SADDLE)(1986-87)	10042212
13.		8.900	BOLT, HEX FLG (M8 X 1 25 X 20)	

2P04-015
052287

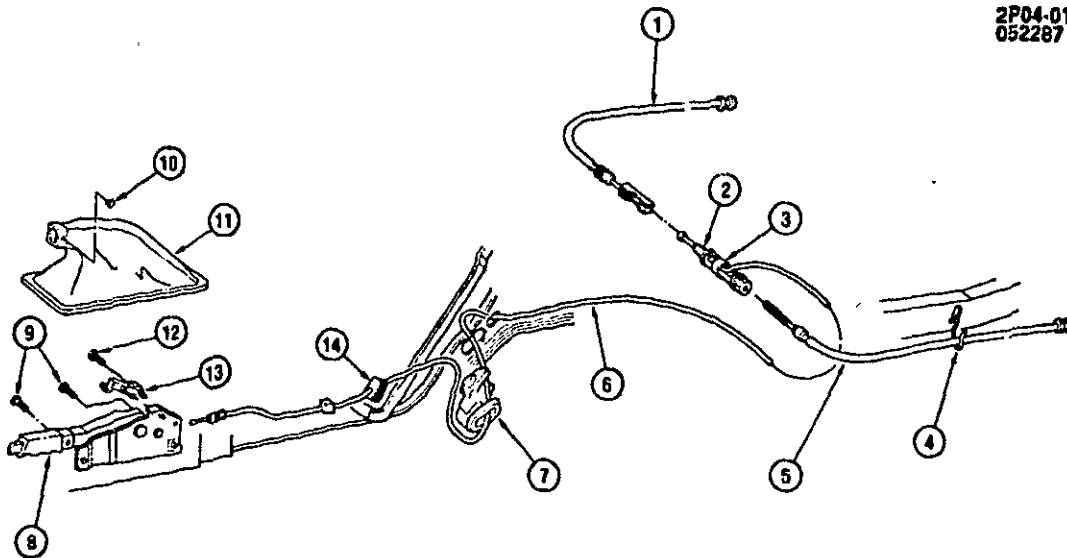

2P04-015

1988 P PARKING BRAKE SYSTEM

1.	D27	4.779	CABLE, RR-RH	10097920
2.	D27	4.785	EQUALIZER, PARK BRK CBL	25512384
3.	D27	4.784	INSULATOR, CBL EQLZR CONN	10087880
4.	D28	4.785	CLIP, CBL	10028881
5.	D27	4.779	CABLE, RR-LH	10057817
6.	D27	4.779	CABLE, FRT	10057816
7.	D28	4.785	GUIDE, FRT CBL	10087887
8.	D23	4.591	LEVER	10046473
9.		8.900	BOLT, HFH (M8X1 25X20) 10 9 POR	11514343
10.	D23	4.812	RETAINER, PARK BRK LVR BOOT	10031158
11.	D23	4.812	BOOT, PARK BRK LVR (DK SADDLE)(62I)	10042212
	D23	4.812	BOOT, PARK BRK LVR (GRAPHITE GRA)(82I)	10042213
12.		8.977	SCREW, HWH TAP (M4 2X1 41X25)(10 783)	1640810
13.	D23	4.589	SWITCH, PARK BRK IND	10026235
14.		N.S.	GROMMET	

PONTIAC CHASSIS GROUP 5.000

ILLUSTRATION INDEX

TITLE	GRID
1984-1988 P AXLE SHAFT/REAR-TRI-POT (W/A.T.)	K5
1984-1988 P AXLE SHAFT/REAR-TRI-POT (W/M.T.)	K7
1984-1985 P WHEELS & WHEEL COVERS	K8
1986 P WHEELS & WHEEL COVERS	K9
1987-1988 P WHEELS & WHEEL COVERS	K10

2P05-002
102385

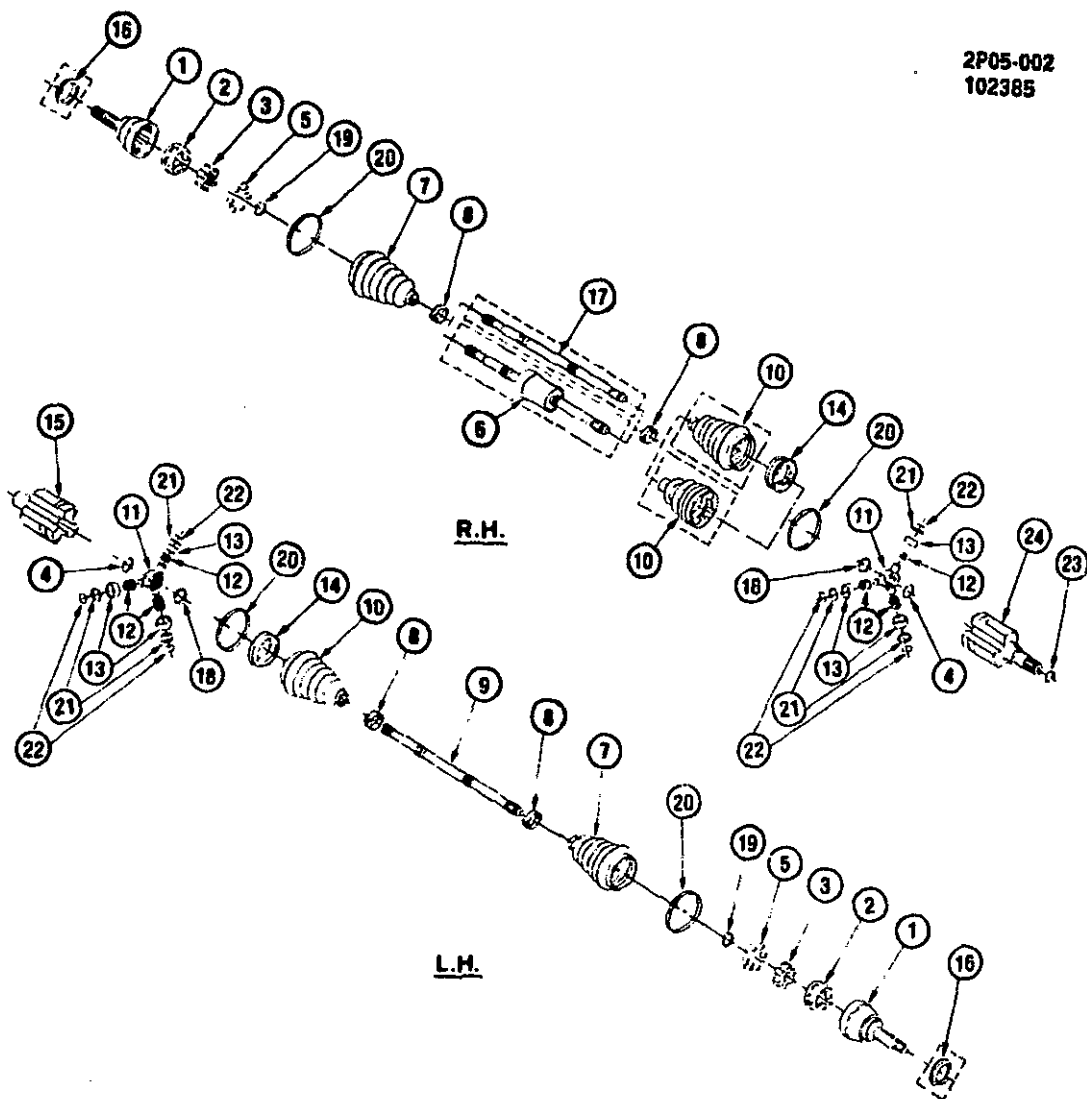

2P05-002

1984-1988 P AXLE SHAFT/REAR-TRI-POT (W/A.T.)

NOTE CONSTANT VELOCITY (CV) JOINTS ARE OUTBOARD AND TRI-POT JOINTS ARE INBOARD JOINTS
 NOTE REFER TO CATALOG GROUP FOR SPECIFIC USAGE AND PART NUMBERS

1.		N.S.	RACE, CV JOINT OUTER(*1)
2.		N.S.	CAGE, CV JOINT(*1)
3.		N.S.	RACE, CV JOINT INNER(*1)
4.	E11	5.422	RING, SHF RET (6 056)(*2)
5.		N.S.	BALL(*1)
6.		N.S.	SHAFT, FRT AXLE W/DAMPER (SEE ITEM #17)
7.		N.S.	SEAL, CV JOINT(*4,7)
8.		6.061	CLAMP, SEAL RETAINING (28.9 DIA)(*3,4)
9.	E10	5.420	SHAFT, FRT AXLE-LH (6 055)
	E10	5.420	SHAFT KIT, DRIVE-LH (6 055)
10.		N.S.	SEAL, TRI-POT JOINT(*3)
11.		N.S.	SPIDER, TRI-POT JOINT(*2)
12.		N.S.	ROLLER, NEEDLE(*2)
13.		N.S.	BALL, TRI-POT JOINT(*2)
14.	E12	5.428	BUSHING, TRILOBAL TRIPL T (6 060)(*3)
15.	E12	5.428	HOUSING, TRIPOT (6 060)
16.	E12	5.428	RING, DEFLECTOR (6 060)(*1)
17.	E10	5.420	SHAFT, FRT AXLE-RH
	E10	5.420	SHAFT KIT, DR-RH
18.	E11	5.422	RING, SPACER (6 056)(*2)
19.	E12	5.428	RING, RACE RET (6 060)(*1)
20.	E11	5.422	CLAMP, SEAL RETAINING(*3,4)
21.		N.S.	RETAINER, NEEDLE(*2)
22.		N.S.	RING, NEEDLE RETAINER(*2)
23.	E12	5.428	RING, JT RET (6 061)
24.	E12	5.428	HOUSING, TRI-POT RH (6 060)

NOTE 1 GROUP 5 428 JOINT KIT (INCL #1,2,3,5,16,19)(6 060)

NOTE 2 GROUP 5 428 SPIDER KIT (INCL #4,11,12,13,18,21,22)(6 060)

NOTE 3 GROUP 5 430 SEAL KIT TRI-POT (INCL #8,10,14,20)(6 061)

NOTE 4 GROUP 5 430 SEAL KIT CV (INCL #6,7,8,20)(6 061)

2P05-003
102385

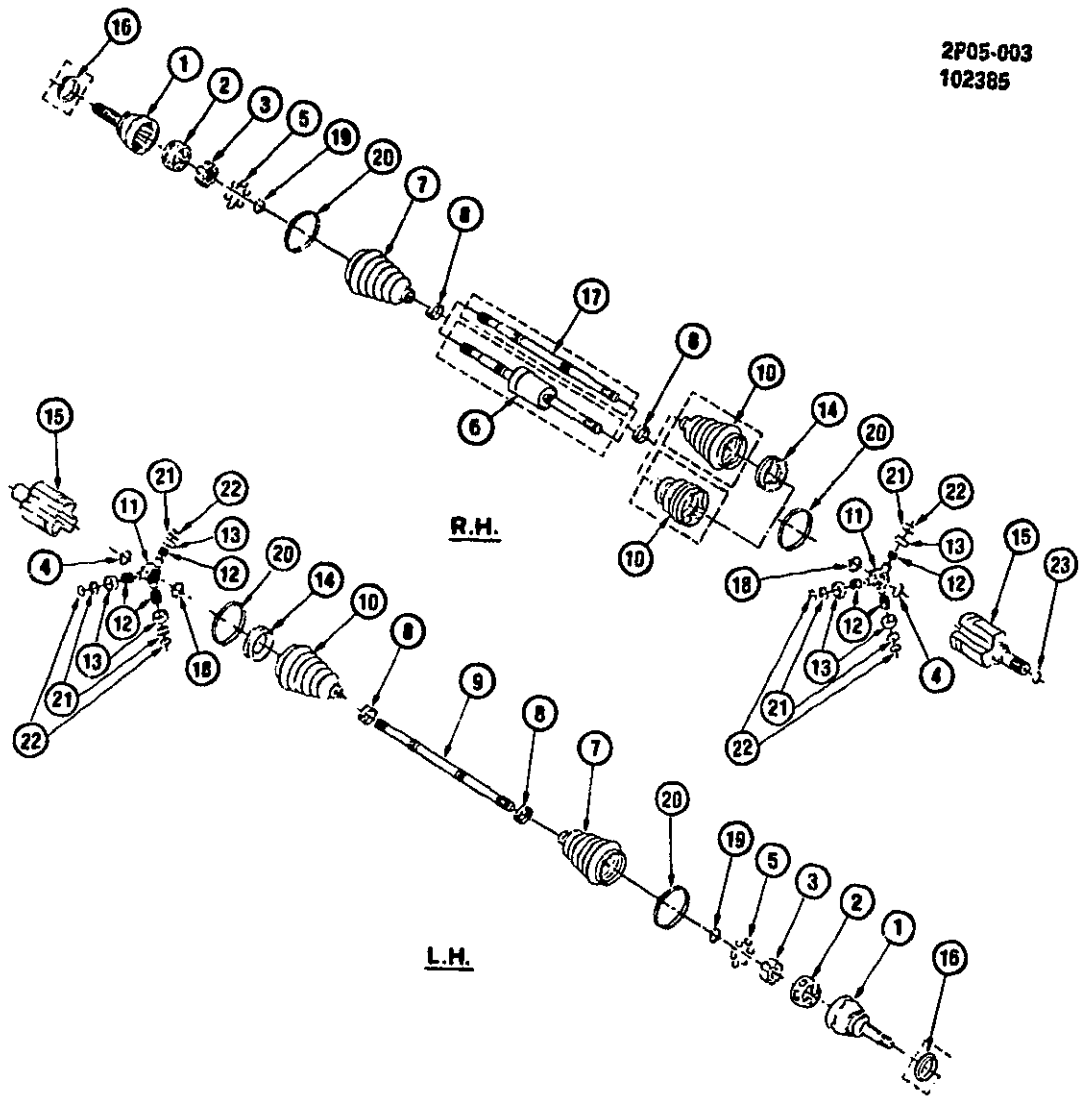

2P05-003

1984-1988 P AXLE SHAFT/REAR-TRI-POT (W/M.T.)

NOTE CONSTANT VELOCITY (CV) JOINTS ARE OUTBOARD AND TRI-POT JOINTS ARE INBOARD JOINTS
NOTE REFER TO CATALOG GROUP FOR SPECIFIC USAGE AND PART NUMBERS

1.	N.S.	RACE, CV JOINT OUTER(*1)
2.	N.S.	CAGE, CV JOINT(*1)
3.	N.S.	RACE, CV JOINT INNER(*1)
4. E11	5.422	RING, SHF RET (6 056)(*2)
5.	N.S.	BALL(*1)
6.	N.S.	SHAFT, FRT AXLE W/DAMPER (SEE ITEM #17)
7.	N.S.	SEAL, CV JOINT(*4,7)
8. E11	5.422	CLAMP, SEAL RET(*3,4)
9. E10	5.420	SHAFT, FRT AXLE-LH (6 055)
E10	5.420	AXLE KIT, DRIVE-LH (6 055)
10.	N.S.	SEAL, TRI-POT JOINT(*3)
11.	N.S.	SPIDER, TRI-POT JOINT(*2)
12.	N.S.	ROLLER, NEEDLE(*2)
13.	N.S.	BALL, TRI-POT JOINT(*2)
14. E12	5.428	BUSHING, TRILOBAL TRIPOT (6 060)
15. E12	5.428	HOUSING, TRIPOT (6 060)
16. E12	5.428	RING, DEFLECTOR (6 060)(*1)
17. E10	5.420	SHAFT, FRT AXLE-RH (6 055)
E10	5.420	AXLE KIT, DRIVE-RH (6 055)
18. E11	5.422	RING, SPACER (6 056)(*2)
19. E12	5.428	RING, RACE RETAINING (6 060)(*1)
20.	6.081	CLAMP, SEAL RETAINING(*3,4)
21.	N.S.	RETAINER, NEEDLE(*2)
22.	N.S.	RING, NEEDLE RETAINER(*2)
23.	6.081	RING, JT RET

NOTE 1 GROUP 5 428 JOINT KIT (INCL #1,2,3,5,16,19)(6 060)

NOTE 2 GROUP 5 428 SPIDER KIT (INCL #4,11,12,13,18,21,22)(6 060)

NOTE 3 GROUP 5 430 SEAL KIT TRI-POT (INCL #8,10,20)(6 061)

NOTE 4 GROUP 5 430 SEAL KIT CV (INCL #6,7,8,20)(6 061)

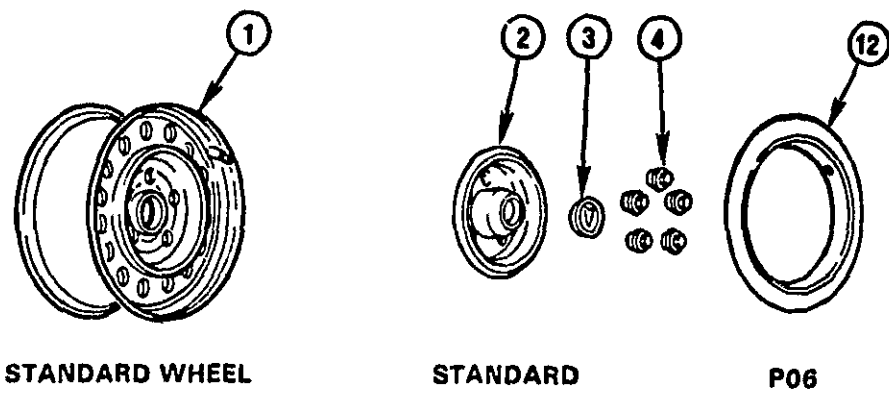

STANDARD WHEEL

STANDARD

P06

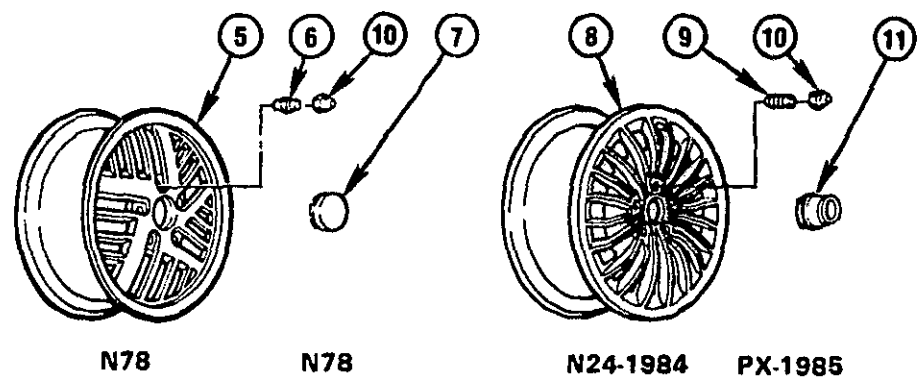

N78

N78

N24-1984

PX-1985

2P05-001

1984-1985 P WHEELS & WHEEL COVERS

1. E15	5.803	WHEEL, STD (13" X 5 5"-TE)	9590763
2. E16	5.858	CAP, HUB (EXC N24.N78)(1984)	10023936
3. E16	5.858	CAP, HUB (1985)	10031312
4. E17	5.871	ORNAMENT, WHL CVR (EXC N24.N78)	10023937
5. E15	5.813	NUT, WHL (M12 X 1 5)	14036301
6. E16	5.803	WHEEL, ALUM (14" X 6")(N78)	10030813
7. E16	5.813	NUT, WHL (M12 X 1 5-M24 X 2)	10091792
8. E16	5.858	CAP, HUB (EXC Y82)	10028300
9. E16	5.858	CAP, HUB(WHT)(Y5.)	10032757
10. E16	5.803	WHEEL, ALUM (13" X 5 5")(N24)	10031138
11. E16	5.813	NUT, WHL (M12 X 1 5-M24 X 2)	10091792
12. E17	5.813	CAP, WHEEL NUT	10028614
	5.858	CAP, WHEEL TRIM	10026140
	5.871	RING, WHL TRIM (13")	10007418

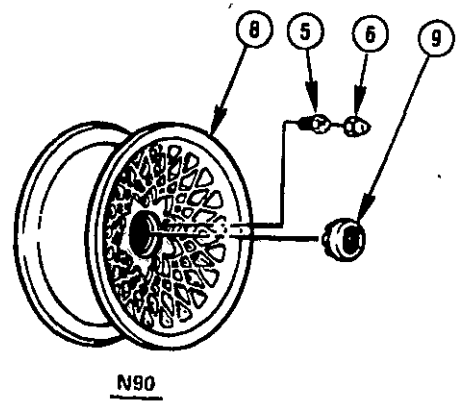
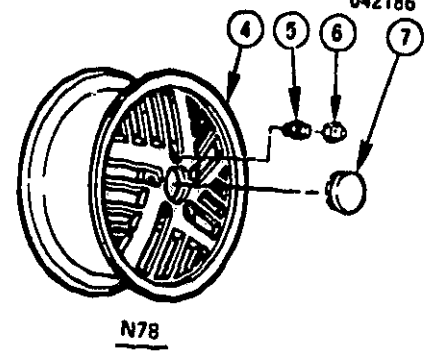
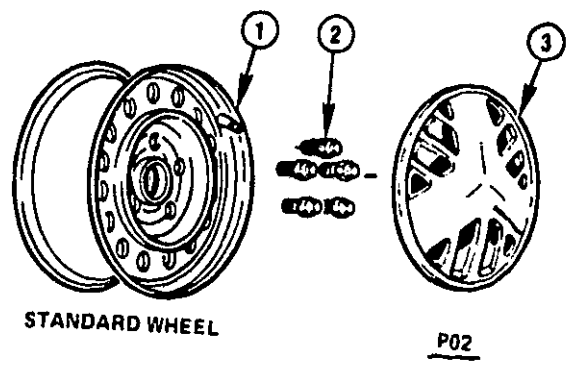

2P05-004

1986 P WHEELS & WHEEL COVERS

1. E16	5.803	WHEEL, (14"X5 5")(STMPD TT)	9591537
2. E16	5.813	NUT, WHL(M12X1 5 HARD PC)EXC RET RG)	9590477
3. E16	5.858	COVER, WHL	10080880
E17	5.875	EXTENSION, TIRE VLV (11/32" LONG)	9422212
4. E15	5.803	WHEEL, (14"X6" ALUM)(STMPD JM)	10030813
5. E16	5.813	NUT, WHL (M12X1 5 THD, W/M24 X 2 OTR THD)	10091792
6. E16	5.813	CAP, WHL NUT	10028614
7. E16	5.858	CAP, HUB	10028300
8. E15	5.803	WHEEL, (15"X7")(STMPD XBZ)(LT GRAY)	10049057
9. E16	5.858	CAP, HUB	10037616

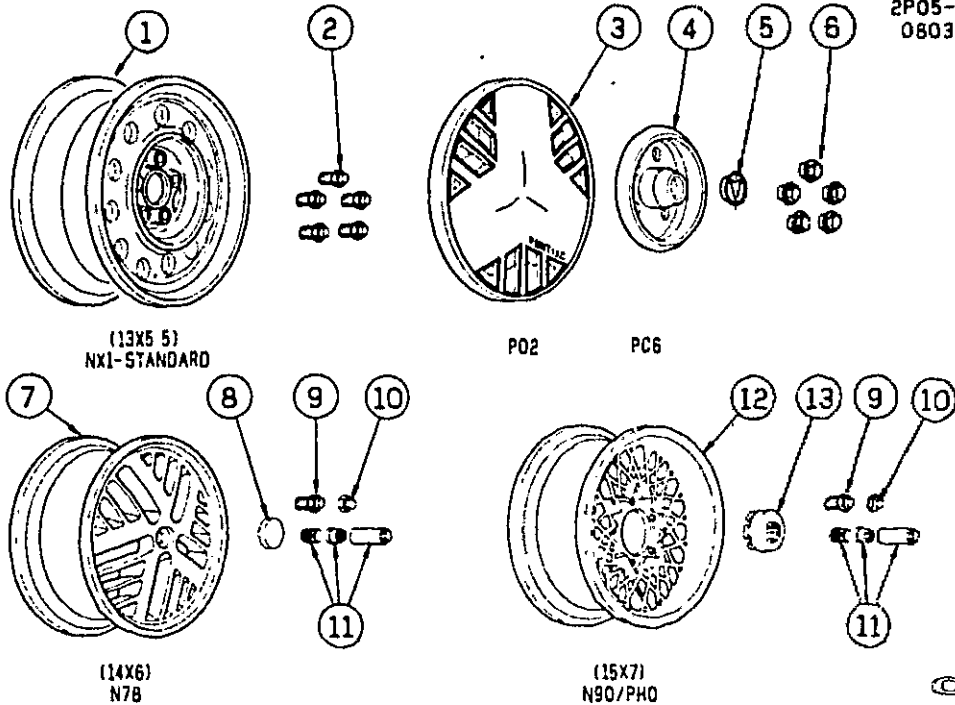

1987-1988 P WHEELS & WHEEL COVERS

1.	E15	5.803	WHEEL, (14 X 5 5)(STMPD TT)	9591537
2.	E16	5.813	NUT, WHL-W/O RFT RING (M12X1 5) HARD PC	9590477
3.	E16	5.858	COVER, WHL TRIM (GOLD)	1008882
	E16	5.858	COVER, WHL TRIM (GRAY)	1008880
4.	E16	5.858	CAP, HUB	10031312
5.	E17	5.871	ORNAMENT, WHL CVR	10021937
6.	E16	5.813	NUT, WHL (M12 X 1 5)	14035301
7.	E15	5.803	WHEEL, ALUM (GOLD)	10046311
	E15	5.803	WHEEL, ALUM (14 X 6)(N78,PB4)(P37)(1988)	10104452
8.	E16	5.858	CAP, HUB (1988)	10028300
9.	E16	5.813	NUT, WHL (M12 X 1 5)	10091791
10.	E16	5.813	CAP, WHL NUT (4-USED PER WHL)	10028514
11.	N28	21.340	NUT PKG,SPL SECURITY WHL (INCLS KEY & NUT CAP)	999057
12.	E15	5.803	WHEEL, (15"X7"XSTMPD X8Z)(LT GRAY)	10049057
13.	E16	5.858	CAP, HUB (1987)	10037616

PONTIAC CHASSIS GROUP 6.000

ILLUSTRATION INDEX

TITLE	GRID
1984-1987 P SUSPENSION/FRONT	F5
1988 P SUSPENSION/FRONT	F7
1984-1988 P STEERING ASM/RACK & PINION	F9
1984-1985 P STEERING WHEEL & HORN PARTS	F11
1986-1987 P STEERING WHEEL & HORN PARTS	F12
1988 P STEERING WHEEL & HORN PARTS	F13
1984-1987 P STEERING SYSTEM & RELATED PARTS	F15
1988 P STEERING SYSTEM & RELATED PARTS	F17
1984 P STEERING COLUMN/TILT (F/S, M.T.)	F19
1984-1988 P STEERING COLUMN/STANDARD (F/S, A.T.)	F22
1984-1988 P STEERING COLUMN/STANDARD (F/S, M.T.)	F24
1984-1988 P STEERING COLUMN/TILT (F/S, A.T.)	F26
1985-1988 P STEERING COLUMN/TILT (F/S, M.T.)	G3

2P06-001
030389

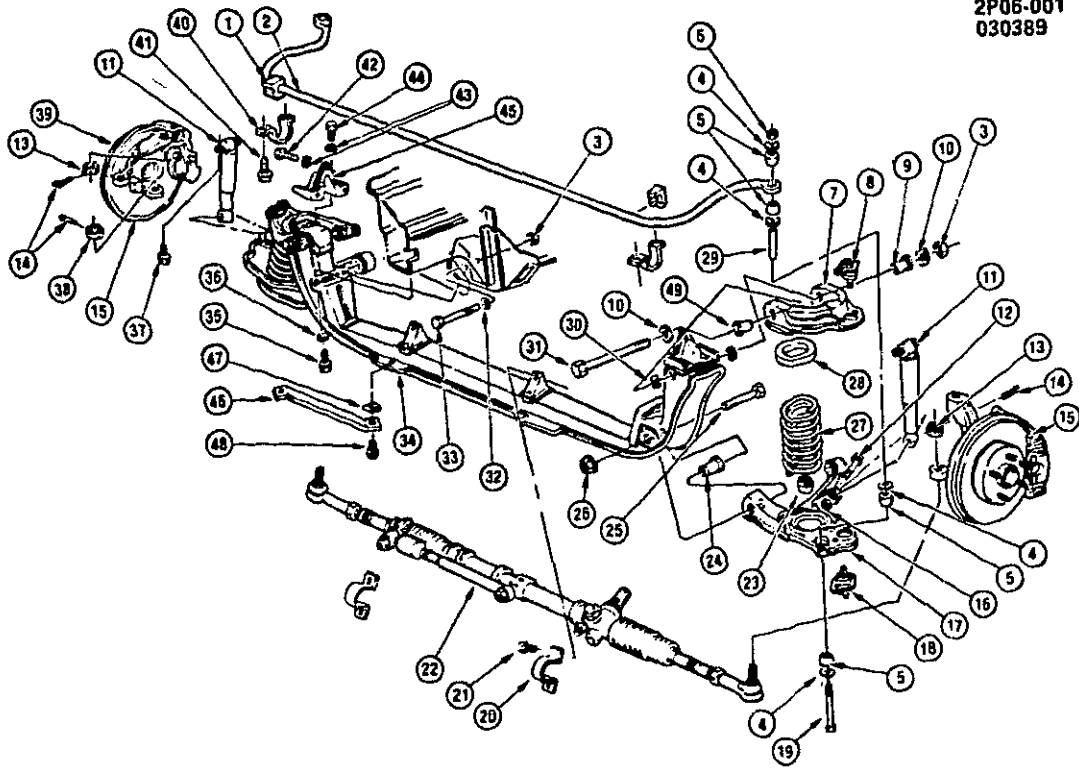

2P08-001

1984-1987 P SUSPENSION/FRONT

1.	B8	7.243	INSULATOR, FRT STAB SHF	363008
2.	B7	7.241	SHAFT, FRT STAB (23MM)	10023227
3.		8.917	NUT, HEX SLOTTED (M10X1X10 WIDE) 10 PC	11508056
4.		8.929	WASHER, FL (M9 1X31 5X3 1) 1010 ZC(*1)	10029761
5.	B8	7.243	GROMMET, STAB BAR (1984)(*1)	10002841
	B8	7.243	INSULATOR, STAB BAR (1984-85)(*1)	6270762
6.		8.915	NUT, HEX STYLE 1 (M8PX1 25) PC(*1)	22521550
7.	A6	6.168	ARM, FRT SUSP UPR CONT-LH	10023748
	A6	6.168	ARM, FRT SUSP UPR CONT-RH	10023747
8.	A6	6.164	BALL JOINT KIT, UPR	9768588
9.	A6	6.164	BUSHING, UPR CONT ARM RR	10027598
10.	A6	6.163	RETAINER, UPR CONT ARM BUSHING	10029804
11.	B8	7.345	ABSORBER, SHK	22048407
12.		8.900	BOLT, HEX (M10X1 5X60)	11509265
13.		8.917	NUT, HEX SLOTTED (M10X1) 10 PC	11508055
14.		8.938	PIN, COTTER (M2 5X25M) PL	103374
15.	A6	6.020	KNUCKLE, STRG-LH(*2)	14001235
16.		8.917	NUT, HEX PREV TQ (M10X1 5) 10 CAD	11501033
17.	A6	6.168	ARM, FRT LWR CONT-LH (1984)	10032528
	A6	6.168	ARM, FRT LWR CONT-RH (1984)	10032527
	A6	6.168	ARM, FRT LWR CONT-LH (1985-87)	10042391
	A6	6.168	ARM, FRT LWR CONT-RH (1985-87)	10042392
18.		N.S.	BALL JOINT, LWR (PART OF ITEM #17)	
19.	B7	7.240	BOLT, SHF LINK(*1)	10022708
20.	A12	6.509	BRACKET, STRG GR MTG	7844353
21.	A12	6.509	BOLT, STRG RACK & PINION MT BRKT	10039989
		8.931	WASHER, Hvy SPRG LK (5/16")	
22.	A8	6.508	GEAR, STRG (1984 EXC WS6)	7846408
	A8	6.508	GEAR, STRG (1984 W/WS6)(*3)	7847087
	A8	6.508	GEAR, STRG (1985)	7847087
	A8	6.508	GEAR, STRG (1986-87 PM37)	7846408
	A8	6.508	GEAR, STRG (1986-87 PG97)	7847087
23.	A7	6.176	BUMPER, LWR C/CAM JOUNCE	10027538
24.	A7	6.170	BUSHING, LWR CONT ARM FRT (1984)	10028261
	A7	6.170	BUSHING, LWR CONT ARM RR (NOT SHOWN)	10042395
	A7	6.170	BUSHING, LWR CONT ARM FRT (1985-86)	10032290
25.		8.900	BOLT, HFH (M12X1 75X90)10 9 POR)	11514112
26.		8.917	NUT, HFH (M12 X 1 75 PREV TORQ)	
27.	B9	7.412	SPRING, FRT(*4)	
28.	B15	7.420	INSULATOR, FRT SPR (1985-87)	363441
29.		N.S.	SPACER, STAB SHF(*1)	
30.		N.S.	WASHER, (PART OF #31)	
31.	A7	6.178	BOLT, FRT UPR CONT ARM TO C MBR	10023888
32.	N16	5.383	WASHER, C/ARM TO FRAME (1984-86)	473539
33.	A7	6.170	BOLT, LWR CONT ARM TO BODY BRKT	10032832
34.	B7	7.010	MEMBER, FRT CR	10084998
35.	B7	7.010	BOLT, HEX HD	10023888
36.		8.929	WASHER, FL (M10X20X3)	10000925
37.		8.900	BOLT, HFH (M8X1 25X20) 10 9 POR	11514343
38.	A7	6.174	NUT, STRG KNU & HUB	14088089
39.	A6	6.020	KNUCKLE, STRG-RH(*2)	14001236
40.	B7	7.242	CLAMP, STAB SHF INSL	10025876
41.		8.977	SCREW, HEX (M8X1 25X25) TYPE T POINT	11501811
42.		8.900	BOLT, HEX (M10 X 1 5 X 30)	
43.	B7	7.039	WASHER, FRT C/MBR TO RAIL UPR (3 275)	10019493
44.		8.900	BOLT, HEX (M10 X 1 5 X 25)	
45.	B7	7.039	BRACKET, FRT C/MBR TO BDY-RH	10031942
	B7	7.039	BRACKET, FRT C/MBR TO BDY-LH	10031943
46.	B7	7.039	BRACE, C/MBR TO SI RAIL	10022736
47.		8.921	NUT, SPRING (M8 X 1 25)	
48.		8.900	BOLT, HEX (M8 X 1 25 X 32)	
49.	A6	6.164	BUSHING, UPR CONT ARM FRT	10023707

NOTE 1 PART OF 7 240 - 10030987 LINK KIT STAB SHF

NOTE 2 SEE EXPLODED VIEW OF FRT DISK BRAKES FOR FURTHER DETAILS

NOTE 3 SEE EXPLODED VIEW OF RACK & PINION STEERING ASM FOR FURTHER DETAILS

NOTE 4 SEE CHART IN GROUP FOR USAGE

2P06-016
080790

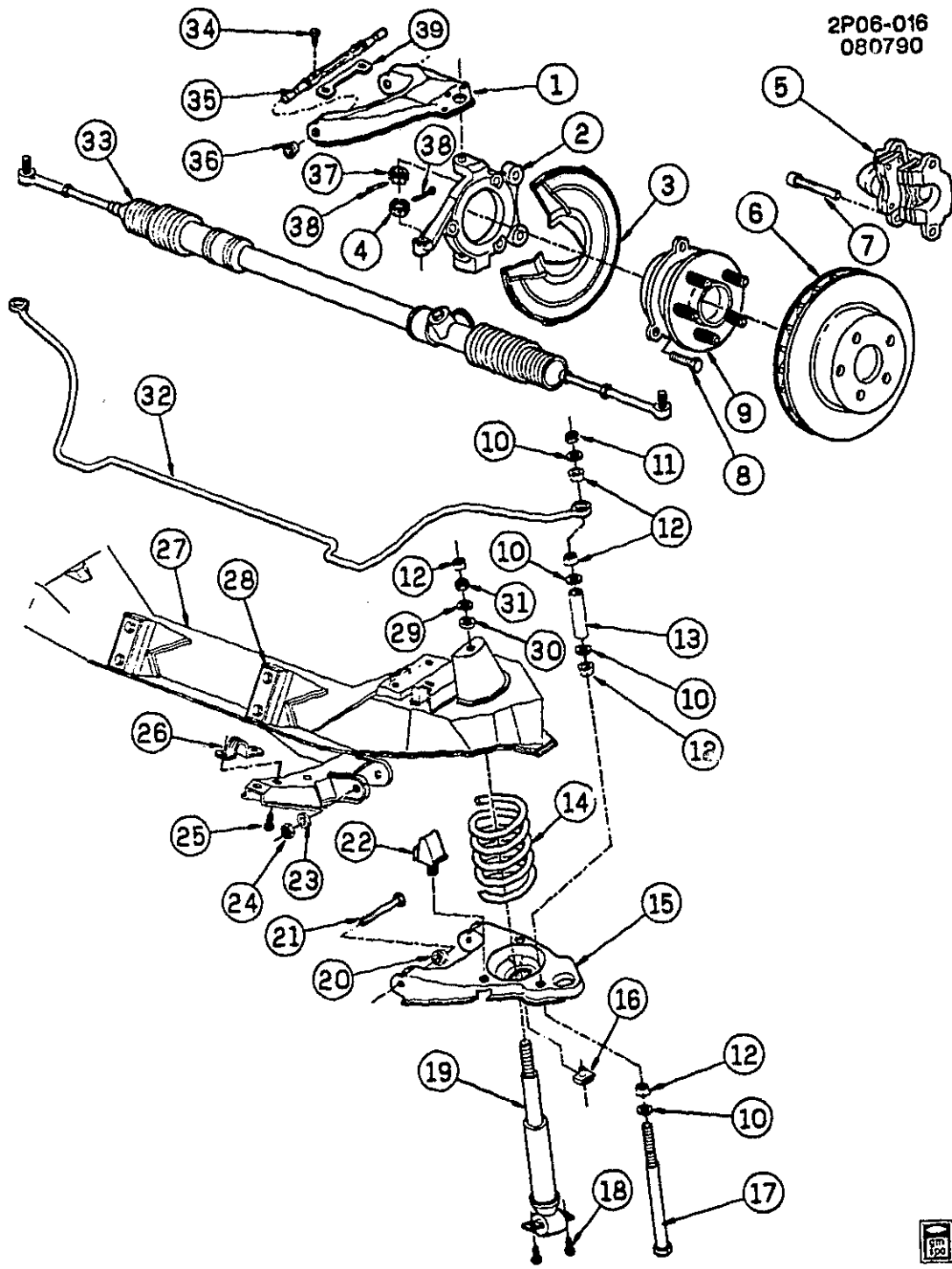

2P06-016



1988 P SUSPENSION/FRONT

1.	A6	6.168	ARM, FRT UPR CONT-RH (EXC SPL PERF PKG WS6)(PM37)	10068614
	A6	6.168	ARM, FRT UPR CONT-LH (EXC SPL PERF PKG WS6)(PM37)	10068613
2.	A6	6.020	KNUCKLE, STRG-RH (MACH)(1988)	10046484
	A6	6.020	KNUCKLE, STRG-LH (MACH)(1988)	10046483
3.	N16	5.002	SHIELD, FRT BRK DISC SPH	10046487
4.		8.917	NUT, HEX SLOTTED (M12X1 25)10 5 THK 10 PC	14088179
5.	N16	4.665	CALIPER, FRT DISC BRAKE-RH	3487472
	N16	4.665	CALIPER, FRT DISC BRAKE-LH	3487471
6.	N20	5.809	ROTOR, BRK (MACH)	10046489
7.	N16	4.665	BOLT, BRK CLPR	10083528
8.	A6	6.009	BOLT, S/KNUCKLE	10083527
9.	A7	6.307	HUB, FRT WHL BRG	7466939
10.		8.929	WASHER, FL (M9 1X31 5X3 1)1010 ZC(* 1)	10029761
11.		8.915	NUT, HEX STYLE 1 (MBPX 1 25)PC(* 1)	22521550
12.	B8	7.243	GROMMET, RR STAB SHF LINK GROM(* 1)	10002641
13.	B8	7.243	SPACER, FRT STAB SHF	14106750
14.	B9	7.412	SPRING, FRT SUSP	10088652
15.	A6	6.168	ARM, FRT LWR CONT-RH	
	A6	6.168	ARM, FRT LWR CONT-LH	
16.		.	NUT, FRT SHK ABS	
17.		.	BOLT, FRT STAB SHF	
18.		8.900	BOLT, HFH (M8X1 25X20) 10 9 POR	11514343
19.	B8	7.345	ABSORBER, SHK	22064058
20.	A7	6.170	BUSHING, FRT LWR CONT ARM (RR)	10042395
21.		.	SCREW, HEX FL HD (M12X1 75X95 0)	
22.	A7	6.176	BUMPER, FRT LWR CONT ARM	10088740
23.	B6	7.006	WASHER, FRM REINF (0 002)	473539
24.	A6	6.008	NUT, FRT SUSP KNU TO KNU (8 917)	11500756
25.		.	BOLT (M8X1 25X20)	
26.	B7	7.242	BRACKET, FRT STAB SHF	14106749
27.	B7	7.010	FRAME, FRT C/MBR	14094421
28.	A12	6.509	BOLT, STRG-RACK & PINION MT BRKT	10039989
29.	B9	7.389	RETAINER, RR SHK ABS INSL	14071397
30.	B9	7.388	GROMMET, FRT S/ABS	14011227
31.		8.915	NUT, HEX (10X1 5X9)PC 10	11500424
32.		.	SHAFT, FRT STAB	
33.	A8	6.508	GEAR, STRG (COMPONENT PARTS SERVICED SEPARATELY)	
34.		.	SCREW, HEX HD (M12X1 75X45)	
35.		N.S.	SHAFT, FRT UPR CONT ARM(*2)	
36.	A6	6.164	BUSHING, FRT UPR CONT ARM	14106713
37.		8.917	NUT, HEX SLOTTED (M10X1X10 WIDE)10 PC	11508055
38.		8.938	PIN, COTTER (3/32X1)PL 1008	103374
39.	A7	6.178	NUT, FRT UPR CONT ARM SHF	10088618

NOTE 1 PART OF 7 240 - 10030987 LINK KIT STAB SHF

NOTE 2 ITEM 35 IS PART OF ITEM 1

2P06-004
062183

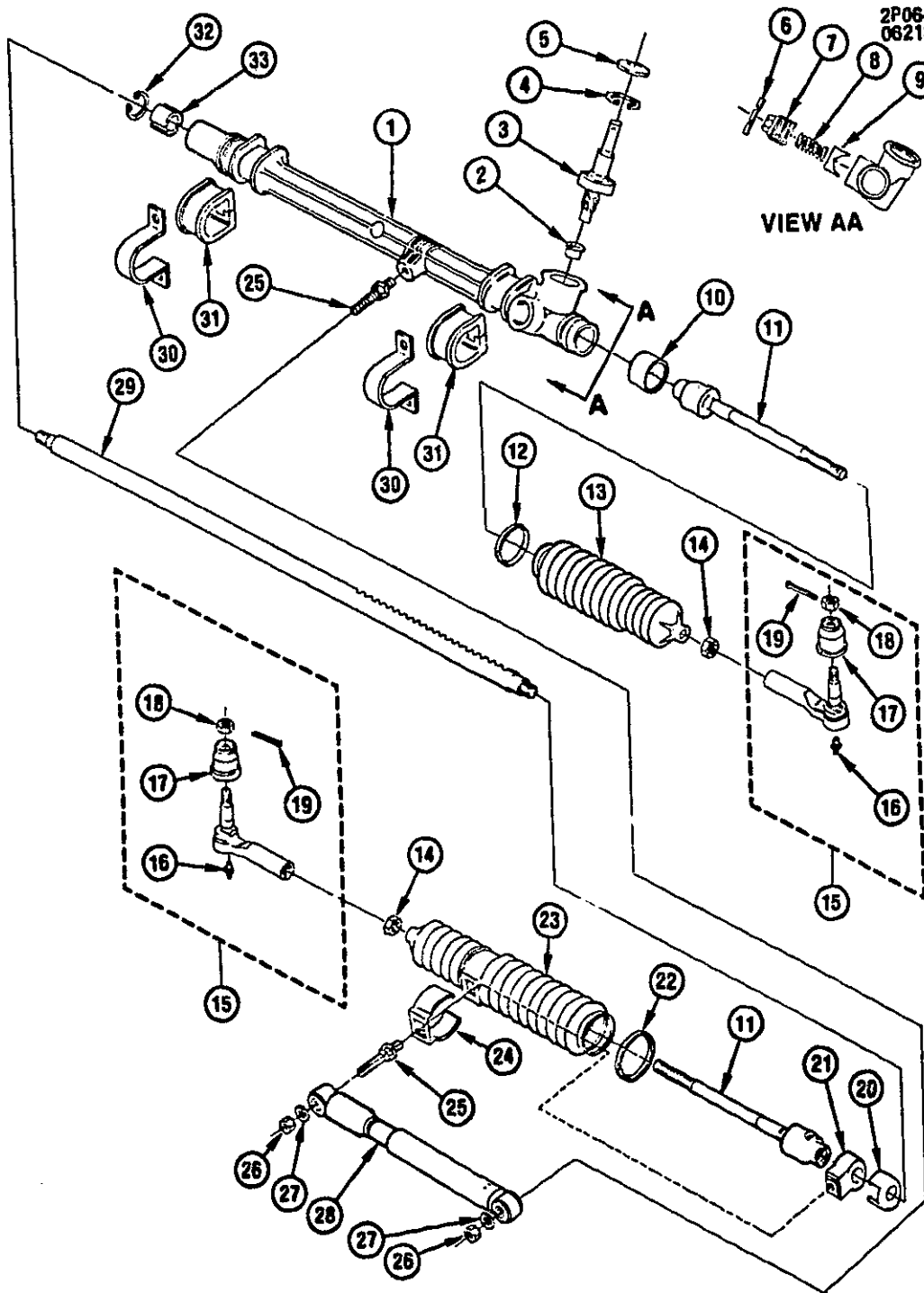

VIEW AA

2P06-004

1984-1988 P STEERING ASM/RACK & PINION

1.	A24	6.803	HOUSING, STRG GR
2.	A24	6.835	BEARING, ROLLER (ALSO PART OF #1)
3.	A23	6.524	PINION, W/BEARING (1984)
	A23	6.524	PINION, W/BEARING (1985 EXC WS6)
	A23	6.524	PINION, W/BEARING (1985 W/WS6)
4.	A24	6.786	RING, RETAINING
5.		N.S.	SEAL, PINION SHF(*1)
6.	A24	6.832	NUT, ADJ PLUG LK
7.	A24	6.832	NUT, ADJ PLUG
8.	A24	6.822	SPRING, ADJ
9.		N.S.	BEARING, STRG GR RACK
10.		N.S.	GUIDE (PART OF #1)
11.		N.S.	ROD, INR TIE(*2)
12.	A7	6.242	CLAMP, BOOT TO HSG(*3)
13.		N.S.	BOOT, LH(*3)
14.	A7	6.234	NUT, INR TIE ROD(*2)
15.	A7	6.233	ROD KIT, OTR TIE (ALSO SERV BY #16-19)
16.		8.984	FITTING, LUBRICATION
17.	A7	6.242	SEAL, TIE ROD
18.		8.915	NUT, HEX SLOTTED (M10 X 1 X 10)(GRADE 10)
19.		8.938	PIN, COTTER (3/32 X 1)
20.	A24	6.885	RING, STRG SHK DAMPENER
	A24	6.885	RING, STRG SHK DAMPER-LH
21.	A23	6.525	ADAPTER, STRG SHK DAMPER
22.	A7	6.242	CLAMP, BOOT TO HSG(*4)
23.		N.S.	BOOT, RH(*4)
24.		N.S.	SUPPORT, BOOT(*4)
25.	A12	6.509	STUD, STRG SHK DAMPER
26.		8.915	NUT, HEX PREV TORQ (M10-1.5)(GRADE 10)
27.	A24	6.885	WASHER, FL (406 X 812 X 065)
28.	A23	6.525	DAMPER, STRG GR
29.	A23	6.586	RACK, STRG GEAR
30.	A12	6.509	BRACKET, STRG GR MTG
31.	A12	6.509	GROMMET, STRG GR MTG (ALSO PART OF #1)(1984)
	A12	6.509	GROMMET, STRG GR MTG (ALSO PART OF #1)(1985)
32.	N20	8.934	RING, INTERNAL RET (1 25" BORE)(ALSO PART OF #1)
33.	A24	6.786	BUSHING, RACK (ALSO PART OF #1)

NOTE 1 PART OF 6 525 7829755-SEAL KIT PINION

NOTE 2 PART OF 6 230 7840738-ROD KIT, INR TIE

NOTE 3 PART OF 6 242 7835171-BOOT KIT INR TIE ROD (LH)

NOTE 4 PART OF 6 242 7840718-BOOT KIT INR TIE ROD (RH)

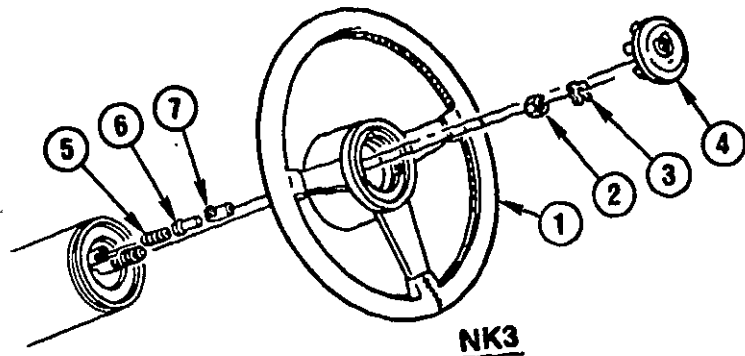

NK3

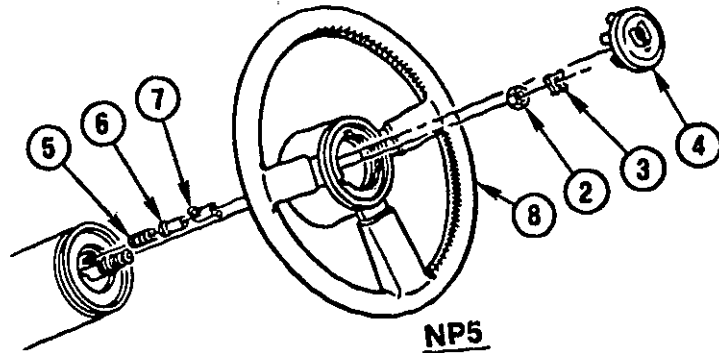

NP5

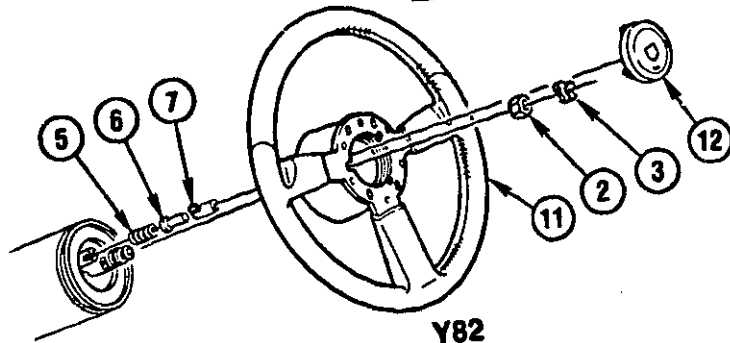

Y82

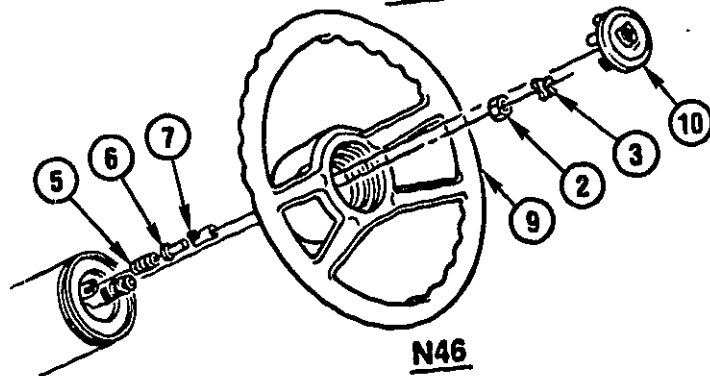

N46

1984-1985 P STEERING WHEEL & HORN PARTS

1.	A12	6.513	WHEEL, STRG (GRAPHITE-131)(NK3)	17982084
	A12	6.513	WHEEL, STRG (MED DK DOESKIN-641)(NK3)	17982085
2.		8.916	NUT, HEX (M14 X 1.5)	
3.	A12	6.515	RETAINER, STRG WHL NUT	419454
4.	N12	2.820	CAP, STRG WHL HORN (BLACK)(NK3/NP5)	10028355
5.	N12	2.819	CONTACT KIT, HORN BLOW	
	N12	2.819	SPRING, HORN CONTACT (COIL SPRING)	404234
6.	N11	2.812	EYELET, STRG WHL HORN CONTACT	10029544
7.	N12	2.819	INSULATOR, STRG WHL HORN CONTACT	10032907
8.	A12	6.513	WHEEL, STRG (GRAPHITE-131)(NP5)	17983232
	A12	6.513	WHEEL, STRG (DK DOESKIN-641)(NP5)	17983233
9.	A12	6.513	WHEEL, STRG (GRAPHITE-131)(N46)	17981867
	A12	6.513	WHEEL, STRG (MED DK DOESKIN-641)(N46)	17981868
10.	N12	2.820	CAP, STRG WHL HORN (GRAPHITE-131)(N46)	10028298
	N12	2.820	CAP, STRG WHL HORN (DK DOESKIN-641)(N46)	10028299
11.	A12	6.513	WHEEL, STRG (1984)	17980911
12.	N12	2.820	CAP, STRG WHL HORN (1984)	10038139

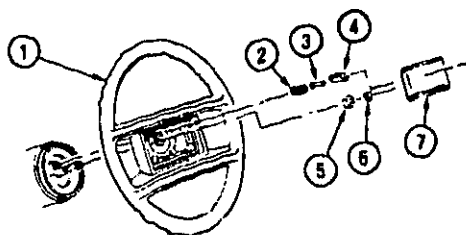

N36-SPORT WHEEL

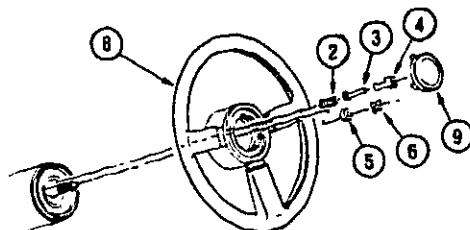

NP5-LEATHER WRAPPED

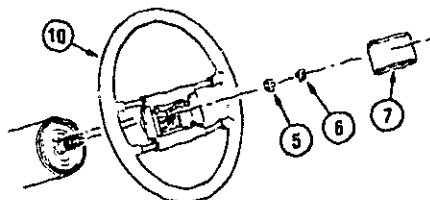

NK4-LEATHER SPORT WHEEL

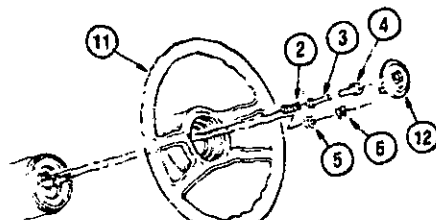

N46



2P06-012

1986-1987 P STEERING WHEEL & HORN PARTS

1.	A12	6.513	WHEEL, STRG (DK GRAY-82I)	17981771
	A12	6.513	WHEEL, STRG (DK SADDLE-62I)	17981772
2.	N12	2.819	SPRING, HORN CONTACT (COIL SPRING)	404234
	N12	2.819	CONTACT, HORN SW (NK4 N36)	17989706
	N12	2.819	SPRING, HORN CONTACT (COIL SPRING)	404234
3.	N11	2.812	EYELET, STRG WHL HORN CONTACT	10029544
4.	N12	2.819	INSULATOR, STRG WHL HORN CONTACT	10032907
5.		8.915	NUT, HEX (M14X1 5)	
6.	A12	6.515	RETAINER, STRG WHL NUT	419454
7.	N12	2.820	CAP, STRG WHL HORN	17983194
8.	A12	6.513	WHEEL, STRG (GRAPHITE-13I)	17983232
	A12	6.513	WHEEL, STRG (LT SADDLE-62I)	17984477
9.	N12	2.820	CAP, STRG WHL HORN	10036400
10.	A12	6.513	WHEEL, STRG (MED DK GRAY-82I)	17981781
	A12	6.513	WHEEL, STRG (LT SADDLE-62I)	17981782
11.	A12	6.513	WHEEL, STRG (DK GRAY-82I)	17884491
	A12	6.513	WHEEL, STRG (DK SADDLE-62I)	17984492
12.	N12	2.820	CAP, STRG WHL HORN (LT SADDLE 62I)	10040018

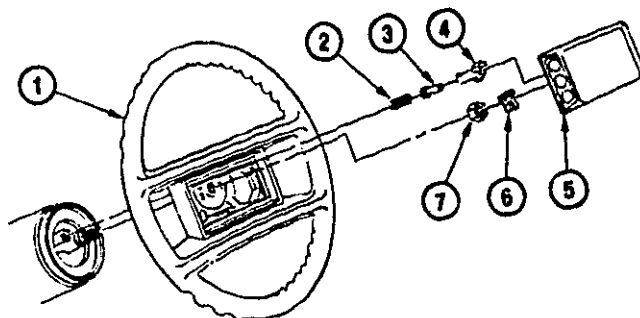

2P08-014
060987

N36

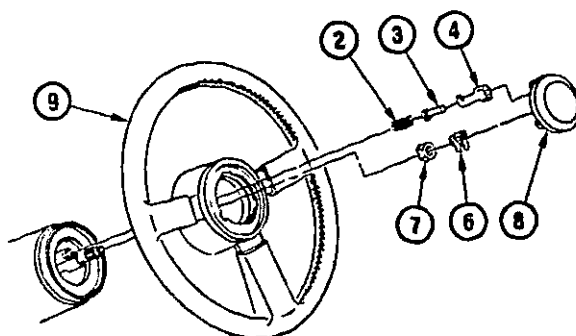

NP5

2P08-014

1988 P STEERING WHEEL & HORN PARTS

1.	A12	6.513	WHEEL, STRG (DK GRAY-82I)	17981771
	A12	6.513	WHEEL, STRG (MED BEECHWOOD-66I)	17988048
2.	N12	2.819	CONTACT KIT, HORN BLOW	
	N12	2.819	CONTACT, HORN SW (N36)	17989708
3.	N11	2.812	EYELET, STRG WHL HORN CNCT	10029544
4.	N12	2.819	INSULATOR, STRG WHL HORN CONTACT	10032907
5.	N12	2.820	CAP, STRG WHL HORN	17983194
6.	A12	6.515	RETAINER, STRG WHL NUT	419454
7.		8.915	NUT, HEX (M14X1 5)	
8.	N12	2.820	CAP, STRG WHL HORN	10036400
9.	A12	6.513	WHEEL, STRG (DK GRAY-82I)	17983232
	A12	6.513	WHEEL, STRG (LT SADDLE-62I)	17984477
	A12	6.513	WHEEL, STRG (MED BEECHWOOD 66I)	17988044

2P06-003
062783

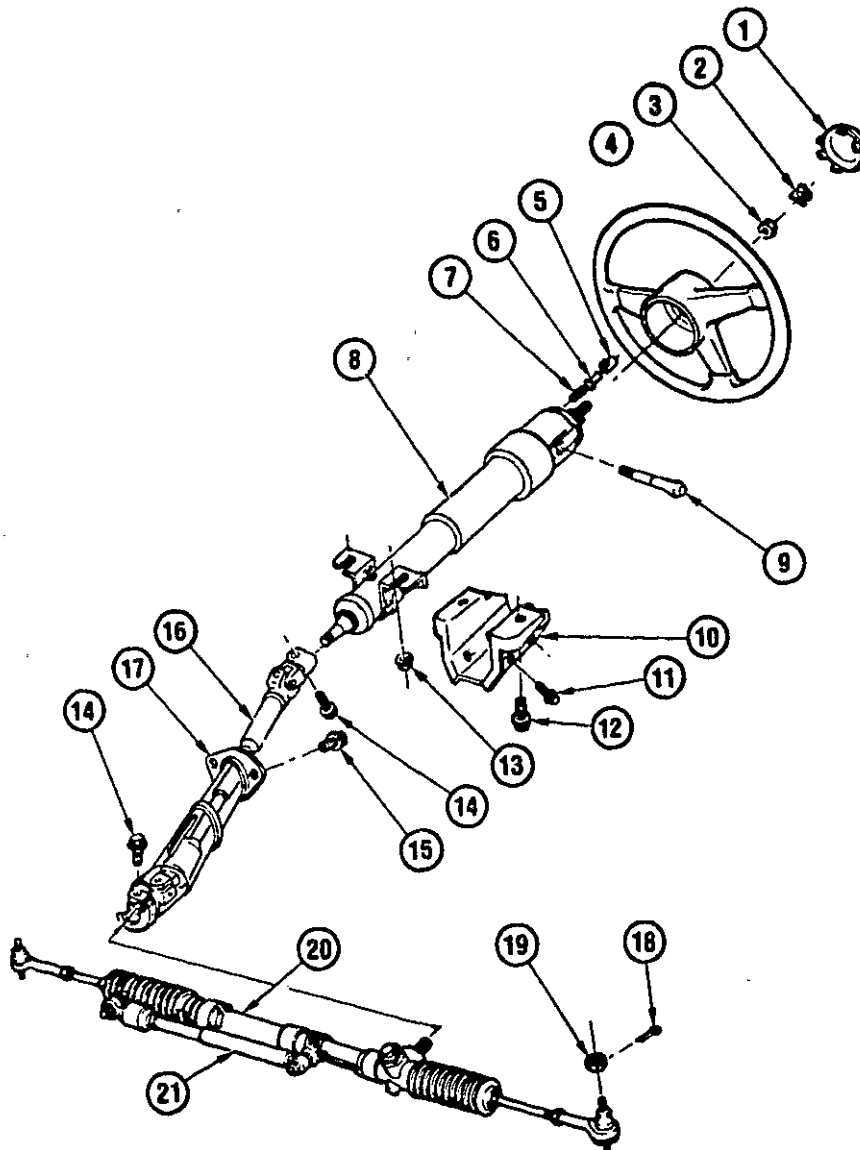

2P08-003

1984-1987 P STEERING SYSTEM & RELATED PARTS

NOTE CD4-PULSE WIPER, F41 RIDGE & HANDLING, NK3 FORMULA STRG WHL, NP5-LEATHER WRAPPED STRG WHL, WU2-GT OPTION, Y82-LIMITED EDITION OPTION, N33-TILT WHL

1.	N12	2.820	CAP, HORN (BLA)(1984-85 W/NK3,NP5 EXC Y82,WU2)(1)	10028356
	N12	2.820	CAP, STRG WHL HORN (1986-87 P97 W/NP5)	10036400
2.	A12	6.515	RETAINER, STRG WHL NUT	419454
3.		8.915	NUT, HEX (M14X1.5) PLAIN GRD 9	7846970
4.	A12	6.513	WHEEL, FORMULA (GRAPHITE-13)(1984-85 W/NK3)(1)	17982084
	A12	6.513	WHEEL, STRG (DK GRAY-82)(1984-87 W/NP5)(1)	17983232
5.	N12	2.819	INSULATOR, HORN CONTACT	10032907
6.	N11	2.812	EYELET, HORN CONTACT	10029544
7.	N12	2.819	CONTACT KIT, HORN BLOW	
8.	A12	6.518	COLUMN, STRG (M.T. EXC CD4,N33)(1984-87)	7844377
	A12	6.518	COLUMN, STRG (M.T. N33 EXC CD4)(1984)	7844381
	A12	6.518	COLUMN, STRG (M.T. CD4 EXC N33)(1984)	7844378
	A12	6.518	COLUMN, STRG (M.T. CD4,N33)(1984)	7844382
	A12	6.518	COLUMN, STRG (M.T. CD4 EXC N33)(1985-86)	7845338
	A12	6.518	COLUMN, STRG (M.T. CD4 EXC N33)(1985)	7844824
	A12	6.518	COLUMN, STRG (M.T. N33 EXC CD4)(1985)	7844381
	A12	6.518	COLUMN, STRG (M.T. CD4,N33)(1987)	26002577
	A12	6.518	COLUMN, STRG (A.T. EXC CD4,N33)(1984-87)	7844375
	A12	6.518	COLUMN, STRG (A.T. N33 EXC CD4)(1984-85)	7844379
	A12	6.518	COLUMN, STRG (A.T. CD4 EXC N33)(1985)	7844823
	A12	6.518	COLUMN, STRG (A.T. CD4 EXC N33)(1984)	7844378
	A12	6.518	COLUMN, STRG (A.T. CD4,N33)(1984)	7844380
	A12	6.518	COLUMN, STRG (A.T. CD4,N33)(1985-86)	7845339
	A12	6.518	COLUMN, STRG (A.T. CD4,N33)(1987)	26002576
9.	A12	6.514	LEVER, T/WHL REL	10024521
10.	A24	6.758	SUPPORT, COL UPR	7839279
11.		8.900	BOLT, (M8X1.25X12) 10.9 PC	11500914
		8.929	WASHER, (23/32X2 1/64X.030)(4.037)	580379
12.		8.900	BOLT, HWH (M10X1.5X45) 9.8 PC	11501194
13.		8.917	NUT, HEX PREV TO (M10X1.5) 10 POR	11508101
14.	A23	6.525	BOLT, INTER SHAFT	26005756
15.		8.977	SCREW, HEX WA HD C/R TAP (M4.2X1.41X20) POR	22536997
16.	A23	6.524	SHAFT, S/GR CPLG (EXC WSG,F41)(1984-85)	7845854
	A23	6.524	SHAFT, S/GR CPLG W/WS6,F41 (1984-85)	7846289
	A23	6.524	SHAFT, S/GR CPLG (1986-87 PM37)	7845854
	A23	6.524	SHAFT, S/GR CPLG (1986-87 PG97)	7846289
17.	A23	6.526	SEAL, S/GR CPLG SHF	10029220
18.		8.938	PIN, COTTER (3/32"X1") PL	103374
19.	A6	6.168	NUT, HEX SLOTTED (M10X1X10) 10 PC (8.917)	11508055
20.	A8	6.508	GEAR, STRG RACK & PINION (1984 EXC WS6)	7846406
	A8	6.508	GEAR, STRG RACK & PINION (1984 W/WS6)	7847087
	A8	6.508	GEAR, STRG RACK & PINION (1985-86)	7847087
	A8	6.508	GEAR, STRG RACK & PINION (1986 P37)	7846406
21.	A23	6.525	DAMPER, STRG LINK	22048471

NOTE 1. SEE STEERING WHEEL ILLUSTRATIONS FOR ADDITIONAL PARTS

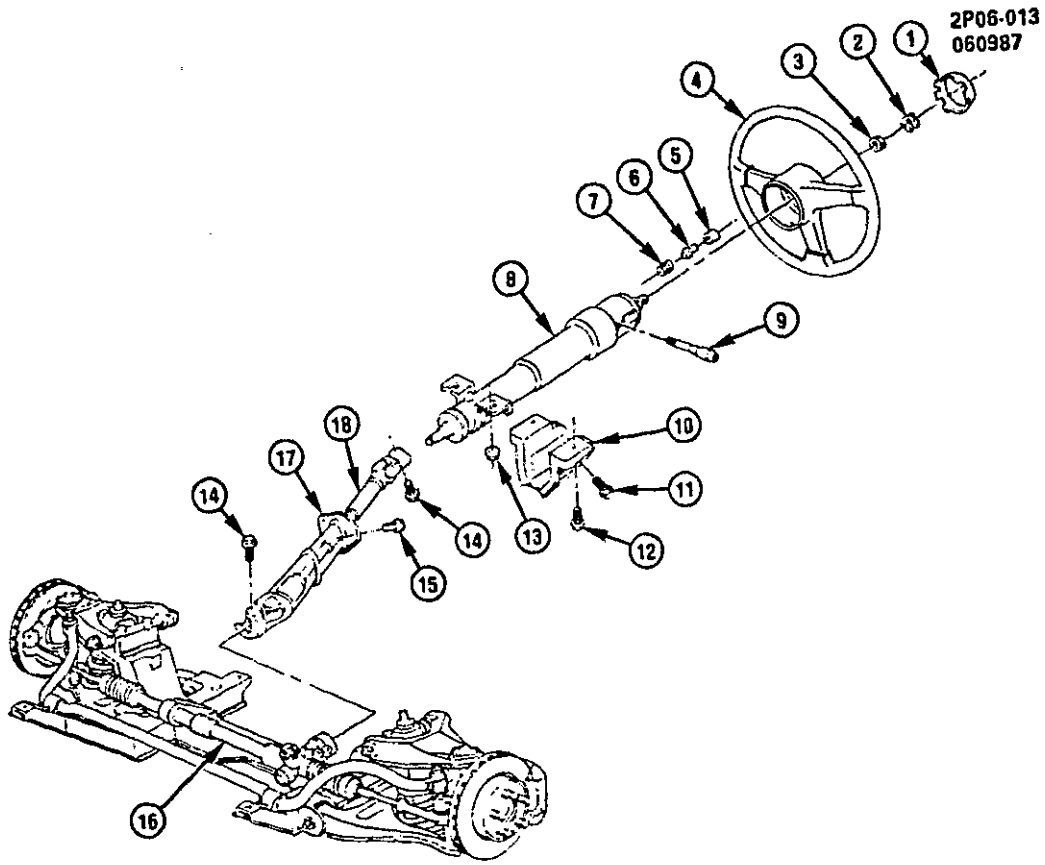

2P06-013
060987

1988 P STEERING SYSTEM & RELATED PARTS

1.	N12	2.820	CAP, STRG WHL HORN (W/NP5)	10036400
	N12	2.820	CAP, STRG WHL HORN (W/NK4 N36)	17983194
2.	A12	6.515	RETAINER, STRG WHL NUT	419464
3.		8.915	NUT, HEX (M14X1 5)PLAIN GRD 9	7846970
4.	A12	6.513	WHEEL, STRG (DK GRA.82)(W/NP5K* 1)	17983232
5.	N12	2.819	INSULATOR, STRG WHL HORN CONTACT	10032907
6.	N11	2.812	EYELET, STRG WHL HORN CNCT (W/NP5)	10029544
7.	N12	2.819	CONTACT KIT, HORN BLOW	
8.	A12	6.518	COLUMN, STRG(*2)	7844377
9.	A12	6.514	LEVER, STRG COL TILT WHL REL	10024521
10.	A24	6.758	SUPPORT, COL UPR	7839279
11.		8.900	BOLT, HEX (M8X1 25X12)10 9 PC	11500914
12.		8.900	BOLT, HEX W/CON WA (M10X1 5X45)9 8 PC	11501194
13.		8.917	NUT, HFH (M10X1 5X10)10 POR	11506101
14.	A23	6.525	BOLT, INTER SHAFT	26005756
15.		8.977	SCREW, HWH (M4 2X1 41X20)(9 20D)(13 8 THD)	22538997
16.		N.S.	SUSPENSION, FRT	
17.	A23	6.519	BOOT, INTER STRG SHF	10054966
18.	A23	6.526	SHAFT, INTER STRG (W/WS6)	7849456
	A23	6.526	SHAFT, STRG (EXC WS6)	26001138

NOTE 1 SEE STEERING WHEEL ILLUSTRATIONS FOR ADDITIONAL PARTS AND COLORS
 NOTE 2 SEE CHART IN GROUP FOR USAGE

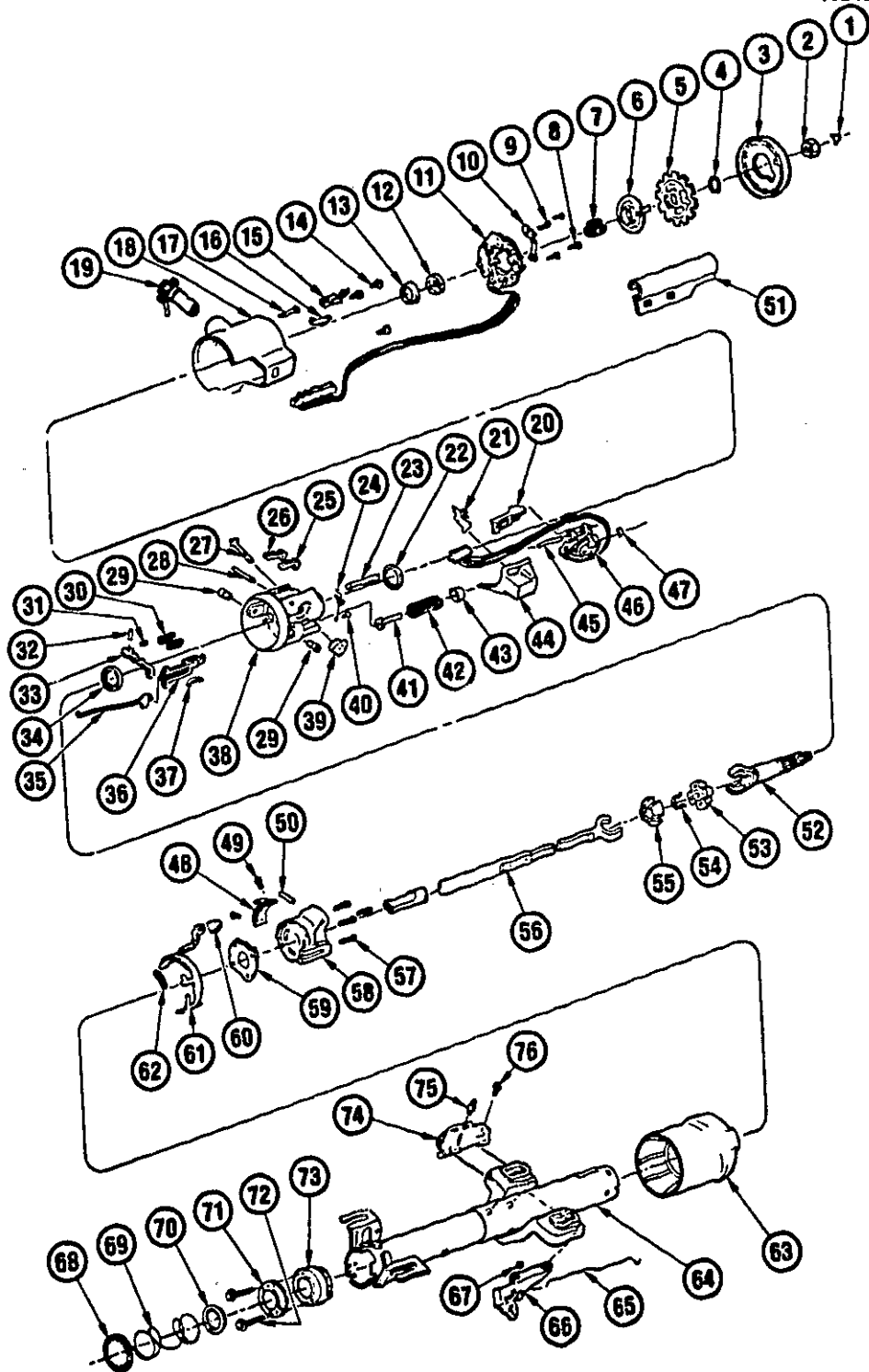

1984 P STEERING COLUMN/TILT (F/S, M.T.)

1.	A12	6.515	RETAINER
2.		8.915	NUT, HEX (M14X1.5)
3.	A8	6.500	COVER, SHF LK
4.	A12	6.515	RING, RET
5.	A8	6.500	LOCK, SHF
6.	N12	2.898	CAM, TURN SIG
7.	A23	6.521	SPRING, UPR BRG
8.	N12	2.895	SCREW, SIG SW MTG
9.		N.S.	SCREW, RD WASHER HD
10.	N12	2.895	ARM, SIG SW
11.	N12	2.895	SWITCH, DIR SIG
12.	A23	6.521	SEAT, UPR BRG INR RACE
13.	A23	6.521	RACE, UPR SHF UPR BRG
14.	N12	2.895	SCREW, (1/4"-20X3/4")
15.	N9	2.195	SWITCH, KEY BUZZER
16.	N9	2.195	CLIP, BUZZER SW RET
17.	N9	2.195	SCREW, LK RET
18.	A12	6.518	COVER, LK HSG
19.	N9	2.188	LOCK, STRG COL
20.	N9	2.459	ACTUATOR, DIMR SW ROD
21.	A12	6.514	SHEILD, TILT LVR OPG
22.	A23	6.521	BEARING, UPR STRG SHF LWR
23.	A8	6.500	BOLT, STRG SHF LK
24.	A8	6.500	SPRING, LK BOLT
25.	A8	6.500	SHOE, LK 3/POSN
26.	A8	6.500	SHOE, LK 4/POSN
27.	N9	2.195	SHAFT, SW SEL
28.	A12	6.514	PIN, TILT LK SHOE RET
29.	A12	6.514	PIN, PIVOT
30.	A12	6.514	SPRING, LK SHOE RET
31.	A12	6.514	SPRING, SHOE REL
32.	A12	6.514	PIN, SHOE REL LVR
33.	A12	6.514	LEVER, SHOE REL
34.	A23	6.521	BEARING, UPR SHF LWR
35.	N9	2.195	ACTUATOR, IGN SW
36.	N9	2.195	RACK, SW ACTR
37.	N9	2.195	SPRING, RACK PRELOAD
38.	A12	6.514	HOUSING, COL
39.	N9	2.195	SECTOR, SW ACTR
40.	A8	6.500	SCREW, SHF LK BOLT SPR
41.	A12	6.514	GUIDE, SPR
42.	A12	6.514	SPRING, COL
43.	A12	6.514	RETAINER, SPR
44.	A12	6.518	CAP, SW HSG CVR END
45.	N9	2.459	PIN, DIMR SW ACTR PIVOT
46.	E12	10.183	SWITCH, W/S WIPER DIMR SW
47.	N9	2.459	SPRING, PIN PRELOAD DIMR SW
48.	A12	6.518	PLATE, SHROUD RET
49.	N14	4.012	SCREW, SHFT DETENT PLATE
50.	A12	6.514	PIN, COL
51.	N12	2.906	PROTECTOR, WIRING
52.	A23	6.524	SHAFT, STRG UPR
53.	A12	6.514	SPHERE, SHF CTR
54.	A12	6.514	SPRING, CTR SPHERE
55.	A12	6.514	SPHERE, SHF CTR
	A12	6.514	SPHERE, SHF CTR
56.	A23	6.524	SHAFT, STRG LWR
57.	A12	6.514	SCREW, HSG SUPT
58.	A12	6.518	SUPPORT, HSG
59.	A12	6.514	PLATE, SUPT LK
60.	A8	6.500	PAD, REL LVR FINGER
61.	A12	6.514	LEVER, KEY REL
62.	A12	6.514	SPRING, KEY REL
63.	A12	6.518	SHROUD, HSG
64.	A12	6.518	JACKET, COL
65.	N9	2.459	ROD, DIMR SW
66.	N9	2.459	SWITCH, DIMR
67.		8.915	NUT, (#10-24)
68.	A23	6.521	RETAINER, LWR SPRING
69.	A23	6.521	SPRING, LWR BRG
70.	A23	6.521	SEAT, LWR BRG
71.	A23	6.521	RETAINER, BRG
72.		8.977	SCREW, HWH TAP (#10-16X3.8")

73.	A23	0.521	BEARING, LWR SHF TUBE (SEE GROUP)
74.	N9	2.188	SWITCH ASM, IGN
75.	N9	2.188	STUD, DIMR & IGN SW MTG
76.	N9	2.188	SCREW, IGN SW

2P06-005
101483

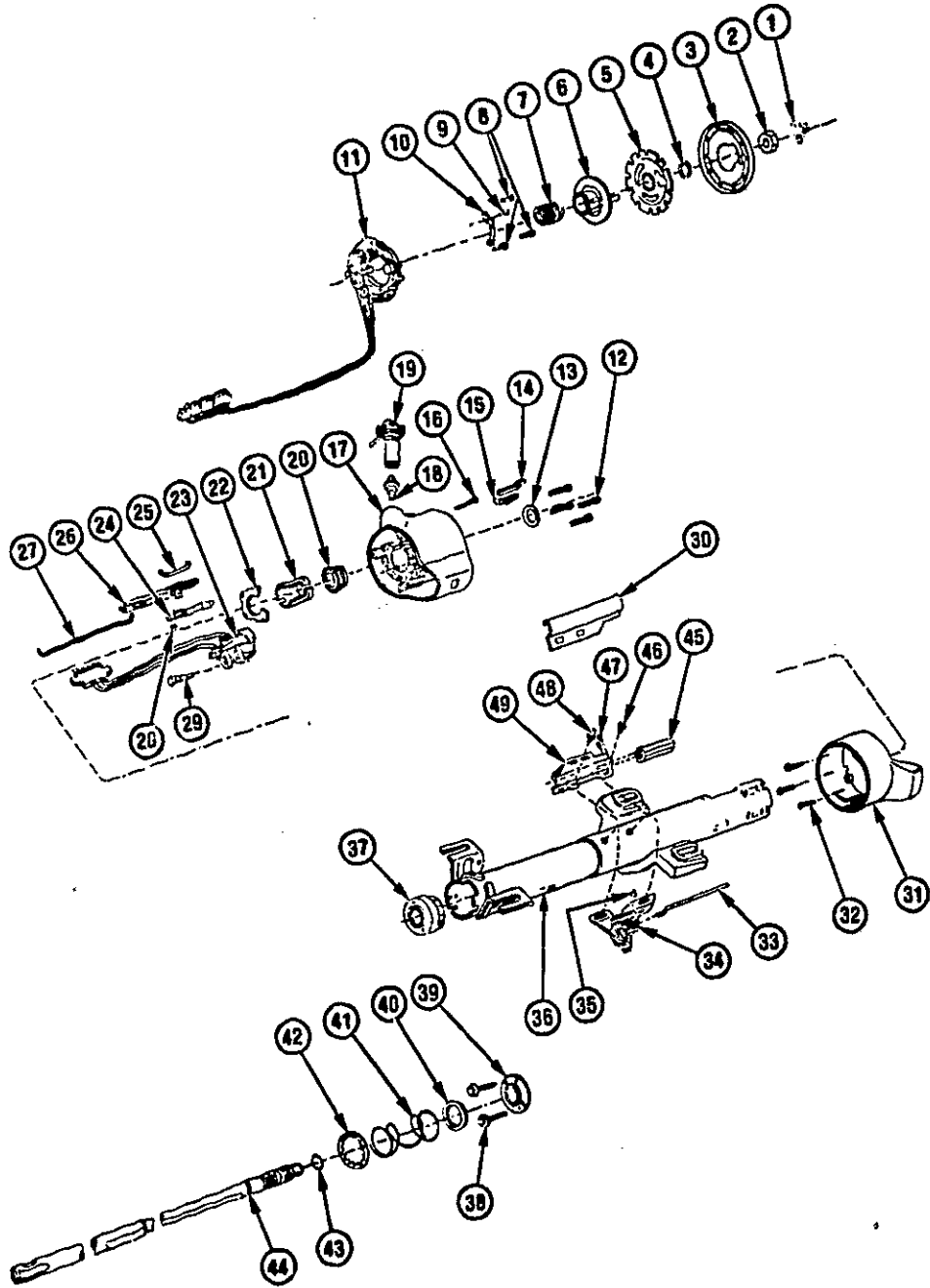

41FE83

2P06-005

1984-1988 P STEERING COLUMN/STANDARD (F/S, A.T.)

1.	A12	6.515	RETAINER, STRG WHL NUT
2.		8.915	NUT, HEX (M14X1 5)
3.	A8	6.500	COVER, STRG SHF LK PLT
4.	A8	6.500	RETAINER, STRG UPR SHF
5.	A8	6.500	LOCK, STRG SHF
6.	N12	2.896	CAM, DIR SIG CANC
7.	A23	6.521	SPRING, SHF UPR BRG
8.	N12	2.895	SCREW, SIG SW MTG
9.		8.977	SCREW, RD WA HD (M4 2X1 41X20)
10.	N12	2.895	ARM, DIR SIG SW ACTR
11.	N12	2.895	SWITCH, DIR SIG
12.	N12	2.906	SCREW, DIR SIG SW HSG
13.	A23	6.521	WASHER, STG SHF UPR RET RING THRUST (4 012)
14.	N9	2.195	SWITCH, IGN KEY WARNING BUZZER
15.	N9	2.195	CLIP, BUZZER SW RET
16.	N9	2.195	SCREW, CYL LK RET
17.	A12	6.518	HOUSING, KIT
18.	N9	2.195	SECTOR, IGN SW ACTR
19.	N9	2.188	LOCK, IGN
20.	A23	6.521	BEARING, HSG
21.	A23	6.521	BUSHING, BRG RET
22.	A23	6.521	RETAINER, UPR BRG
23.	E12	10.183	SWITCH, PIVOT & 2SPD
24.	A8	6.500	BOLT, LOCK
25.	N9	2.195	SPRING, IGN SW RACK PRELOAD
26.	N9	2.195	RACK, SWITCH ACTR
27.	N12	2.819	ROD, SWITCH ACTR
28.	A8	6.500	WASHER, LK BOLT SPR THRUST
29.	N9	2.459	PIN, DIMR SW ACTR PIVOT
30.	N12	2.906	PROTECTOR, FLR SHFT
31.	A12	6.518	BOWL, FLR SHFT
32.	A23	6.521	SCREW, BINDING HD CROSS RECESS
33.	N9	2.459	ROD, D/SW ACTR
34.	N9	2.459	SWITCH, DIMR
35.		N.S.	NUT, HEX
36.	A12	6.518	JACKET, COL
37.	A23	6.521	ADAPTOR, STRG SHF LWR BRG
38.		8.977	SCREW, HWH TAP (# 10-16X3/8")
39.	A23	6.521	RETAINER, LWR BRG ADPT
40.	A23	6.521	SEAT, LER BRG
41.	A23	6.521	SPRING, LWR BRG
42.	A23	6.521	RETAINER, LWR SPR
43.	N20	8.934	RING, RET
44.	A23	6.524	SHAFT, STRG COMPLETE
45.	N9	2.188	HOUSING, IGN SW
46.		8.977	SCREW, WA HD
47.		8.977	SCREW, PAN HD
48.	N9	2.188	STUD, DIMMER & IGN SW MTG
49.	N9	2.188	SWITCH, IGN

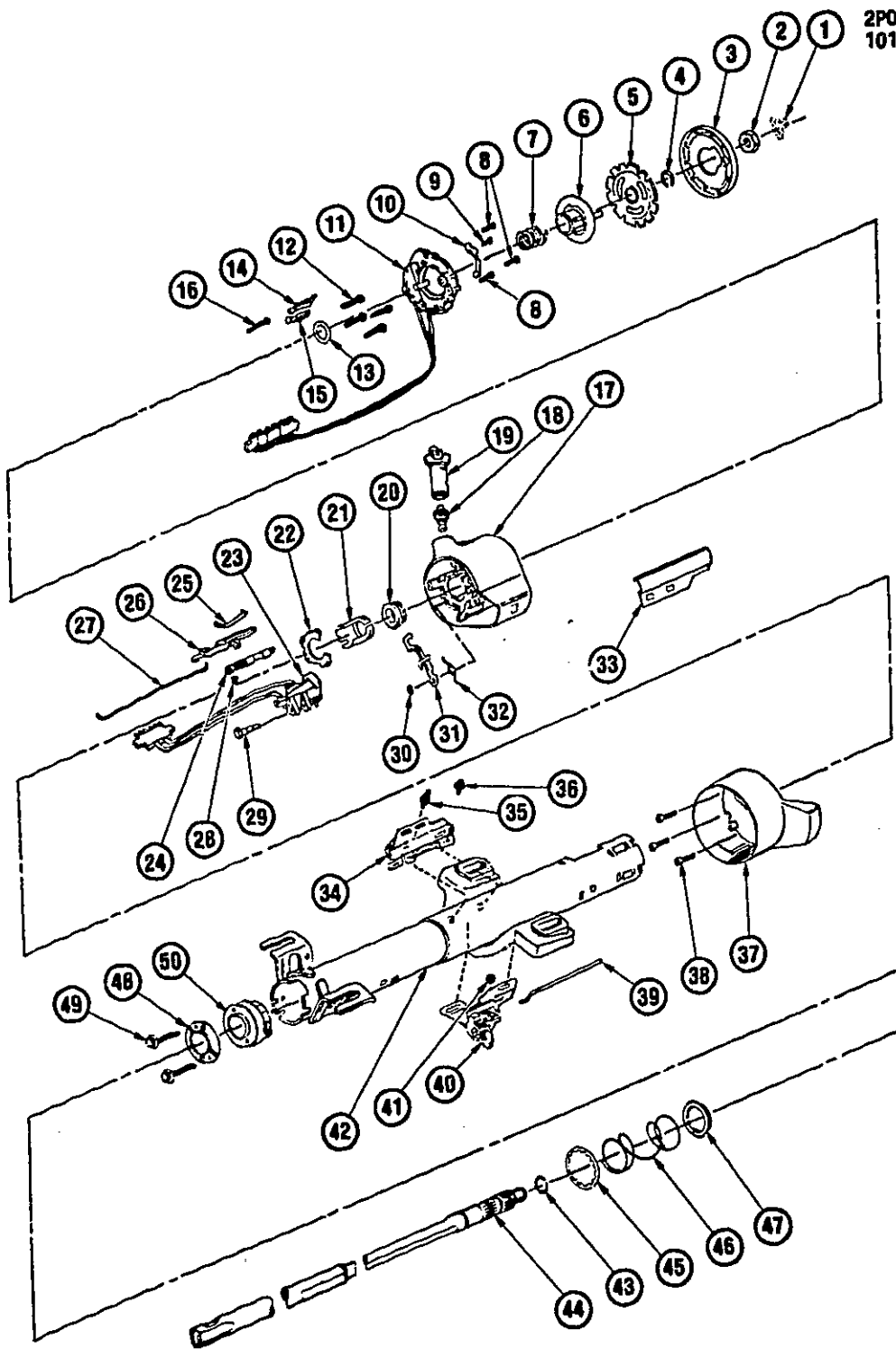

1984-1988 P STEERING COLUMN/STANDARD (F/S, M.T.)

1.	A12	8.515	RETAINER, WHL NUT
2.		8.915	NUT, HEX (M14X1.5)
3.	A8	6.500	COVER, SHF LK
4.	A8	6.500	RETAINER, PLATE
5.	A8	6.500	LOCK, SHF
6.	N12	2.896	CAM, CANCEL
7.	A23	6.521	SPRING, UPR HSG
8.	N12	2.896	SCREW, SIG SW MTG
9.		N.S.	SCREW, RD HD
10.	N12	2.896	ARM, SW ACTR
11.	N12	2.896	SWITCH, DIR SIG
12.	N12	2.906	SCREW, SW HSG
13.	N14	4.012	WASHER, THRUST
14.	N9	2.195	SWITCH, KEY BUZZER
15.	N9	2.195	CLIP, BUZZER SW RET
16.	N9	2.195	SCREW, LK CYL
17.	A12	6.518	HOUSING, KIT. COL
18.	A12	6.518	SECTOR, SW ACTR
19.	N9	2.188	LOCK, IGN
20.	A23	6.521	BEARING, HSG
21.	A23	6.521	BUSHING, BRG
22.	A23	6.521	RETAINER, UPR BRG
23.	E12	10.163	SWITCH, W/PIVOT
24.	A8	6.500	BOLT, W/SPRING SHF LK
25.	N9	2.195	SPRING, RACK PRELOAD
26.	N9	2.195	RACK, SW ACTR
27.	N9	2.195	ROD, SW ACTR
28.	A8	6.500	WASHER, SPR THRUST
29.		2.495	PIN, DIMR SW
30.	N9	2.195	WASHER, WAVE
31.	A8	6.500	LEVER, IGN KEY REL
32.	A8	6.500	SPRING, IGN KEY REL
33.	N12	2.906	PROTECTOR, WIRING
34.	N9	2.188	SWITCH, IGN
35.	N9	2.188	SCREW, IGN SW
36.	N9	2.188	STUD, DIMR MTG
37.	A12	6.518	BOWL, FLR SHFT
38.	N12	2.895	SCREW, SW MTG
39.	N9	2.459	ROD, DIMR SW ACTR
40.	N9	2.459	SWITCH, DIMR
41.		8.915	NUT, (#10-24)
42.	A12	6.518	JACKET, COL
43.	A8	6.500	RETAINER, PLATE
44.	A23	6.524	SHAFT, STRG
45.	A23	6.521	RETAINER, LWR SPRING
46.	A23	6.521	SPRING, LWR BRG
47.	A23	6.521	SEAT, LWR BRG
48.	A23	6.521	RETAINER, BRG
49.		8.977	SCREW, HWH TAP (#10-16X3/8")
50.	A23	6.521	BEARING, LWR SHF TUBE(*1)

NOTE 1. SEE CHART IN GROUP FOR USAGE.

2P06-008
101783

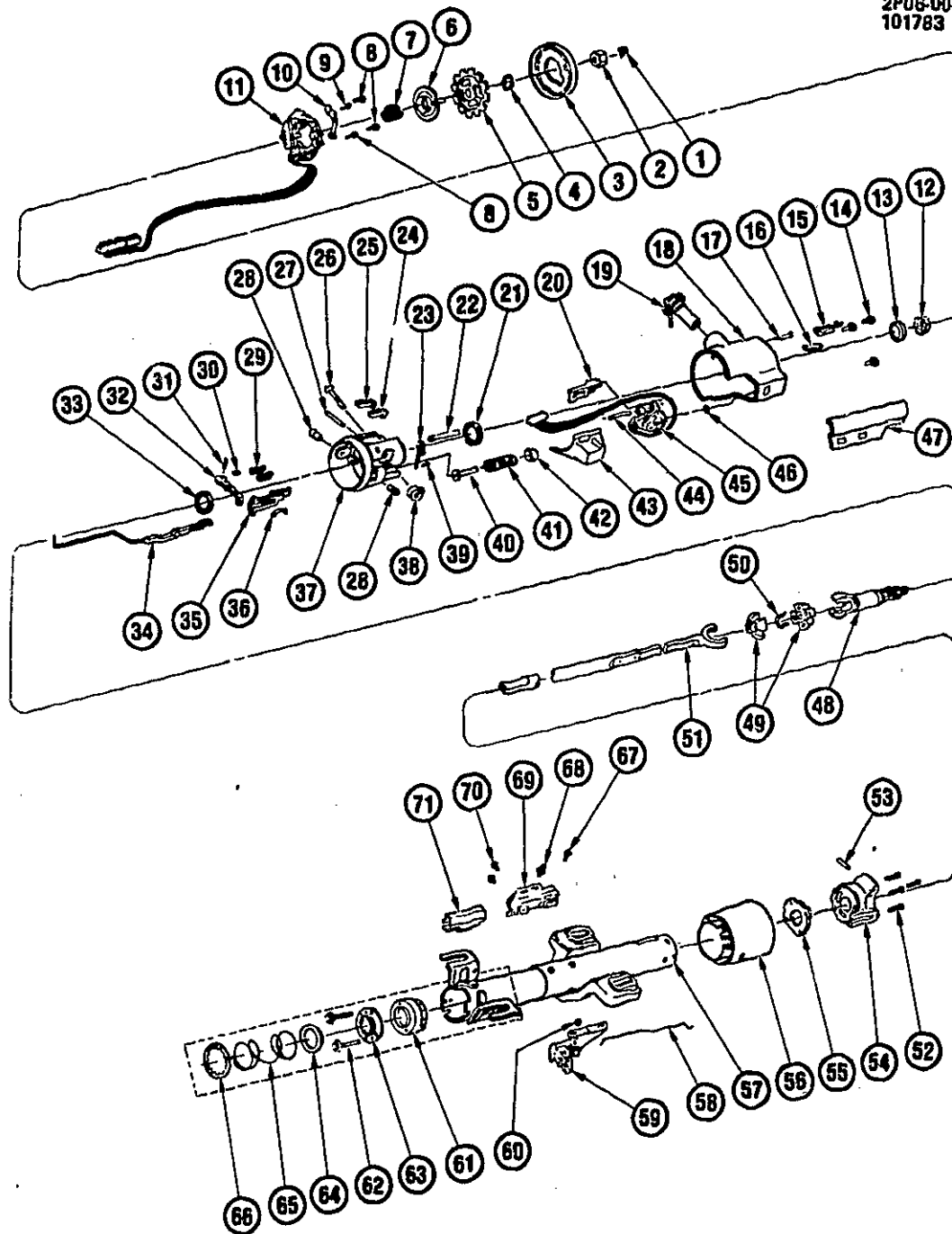

2P06-008

1984-1988 P STEERING COLUMN/TILT (F/S. A.T.)

1.	A12	6.516	RETAINER, NUT
2.		8.915	NUT, HEX (M14X1 5)
3.	A8	6.500	COVER, STRG SHF LK PLT
4.	N20	8.934	RING, RET
5.	A8	6.500	LOCK, STRG SHF
6.	N12	2.896	CAM, DIR SIG CANC
7.	A23	6.521	SPRING, SCH UPR BRG
8.	N12	2.895	SCREW, SWITCH MTG
9.		8.977	SCREW, RD WA HD (M4.2X1 41X20)
10.	N12	2.895	ARM, DIR SIG SW ACTR
11.	N12	2.895	SWITCH, DIR SIG
12.	A23	6.521	SEAT, SHF UPR BRG INR RACE(*2)
13.	A23	6.521	RACE, UPR SHF UPR BRG(*1,2)
14.	N12	2.895	SCREW, HSG CVR
15.	N9	2.195	SWITCH, IGN KEY WARN BUZZER
16.	N9	2.195	CLIP, BUZZER SW RET
17.	N9	2.195	SCREW, CYL LOCK RET
18.	A12	6.518	COVER, LK HSG
19.	N9	2.188	LOCK, IGN (CODED W/KEY)
20.	N9	2.459	ACTUATOR, DIMR SW ROD
21.		N.S.	BEARING, UPR STRG SHF(*1)
22.	A8	6.500	BOLT, SHF LK
23.		N.S.	SPRING, SHF LK BOLT(*1)
24.	A12	6.514	SHOE, LK
25.	A12	6.514	SHOE, LK
26.	N9	2.195	SHAFT, IGN SW SET DRIVE
27.	A12	6.514	PIN, TILT LK SHOE RET
28.	A12	6.514	PIN, PIVOT-TILT(*2)
29.	A12	6.514	SPRING, LK SHOE RETURN
30.	A12	6.514	SPING, SHOE REL
31.	A12	6.514	PIN, SHOE REL LVR
32.	A12	6.514	LEVER, SHOE REL
33.		N.S.	BEARING, LWR STRG SHF(*1)
34.	N9	2.195	ACTUATOR, IGN SW
35.	N9	2.195	RACK, IGN SW ACTR(*1)
36.	N9	2.195	SPING, IGN SW RACK PRELOAD
37.	A12	6.514	HOUSING, KIT. COL
38.		N.S.	SECTOR, IGN SW ACTR(*1)
39.		N.S.	SCREW, LK SPR BOLT(*1)
40.	A12	6.514	GUIDE, STRG WHL TILT SPR(*2)
41.	A12	6.514	SPRING, WHL TILT(*2)
42.	A12	6.514	RETAINER, TILT SPR(*2)
43.	A12	6.518	CAP, COL HSG CVR END
44.	N9	2.459	PIN, SW ACTR PIVOT
45.	N9	2.459	SWITCH, PIVOT & PULSE
46.		N.S.	SPRING, PRELOAD (PART OF 45)
47.	N12	2.906	PROTECTOR, WIRING
48.	A23	6.524	SHAFT, W/RACE, UPR
49.	A12	6.514	SPHERE, CTR
50.	A12	6.514	SPRING, CTR SPHERE
51.	A23	6.524	SHAFT, STRG LWR
52.	A12	6.514	SCREW, SUPT
53.		N.S.	PIN, DOWEL
54.	A12	6.518	SUPPORT, HSG
55.	A12	6.514	PLATE, SUPT LK
56.	A12	6.518	SHROUD, STRG COL HAG
57.	A12	6.518	JACKET, COL (SEE GROUP)
58.	N9	2.459	ROD, DIMR SW
59.	N9	2.459	SWITCH, DIMR
60.		8.921	NUT, HEX
61.	A23	6.521	BEARING, LWR SHF TUBE (SEE GROUP)
62.		8.977	SCREW, HWH TAP (#10-16X3/8")
63.	A23	6.521	RETAINER, BRG
64.	A23	6.521	SEAT, LWR BRG
65.	A23	6.521	SPRING, LWR BRG
66.	A23	6.521	RETAINER, LWR SPRING
67.	A8	6.500	SCREW, WASHER HD
68.	N9	2.188	STUD, DIMMER & IGN SW MTG
69.	N9	2.188	SWITCH, IGN
70.		8.977	SCREW, PAN HD
71.	N9	2.188	HOUSING, IGN SW INHIBITOR

NOTE 1 RACK KIT, GROUP 2 195 INCL'S 13,21,23,33,35,38,39

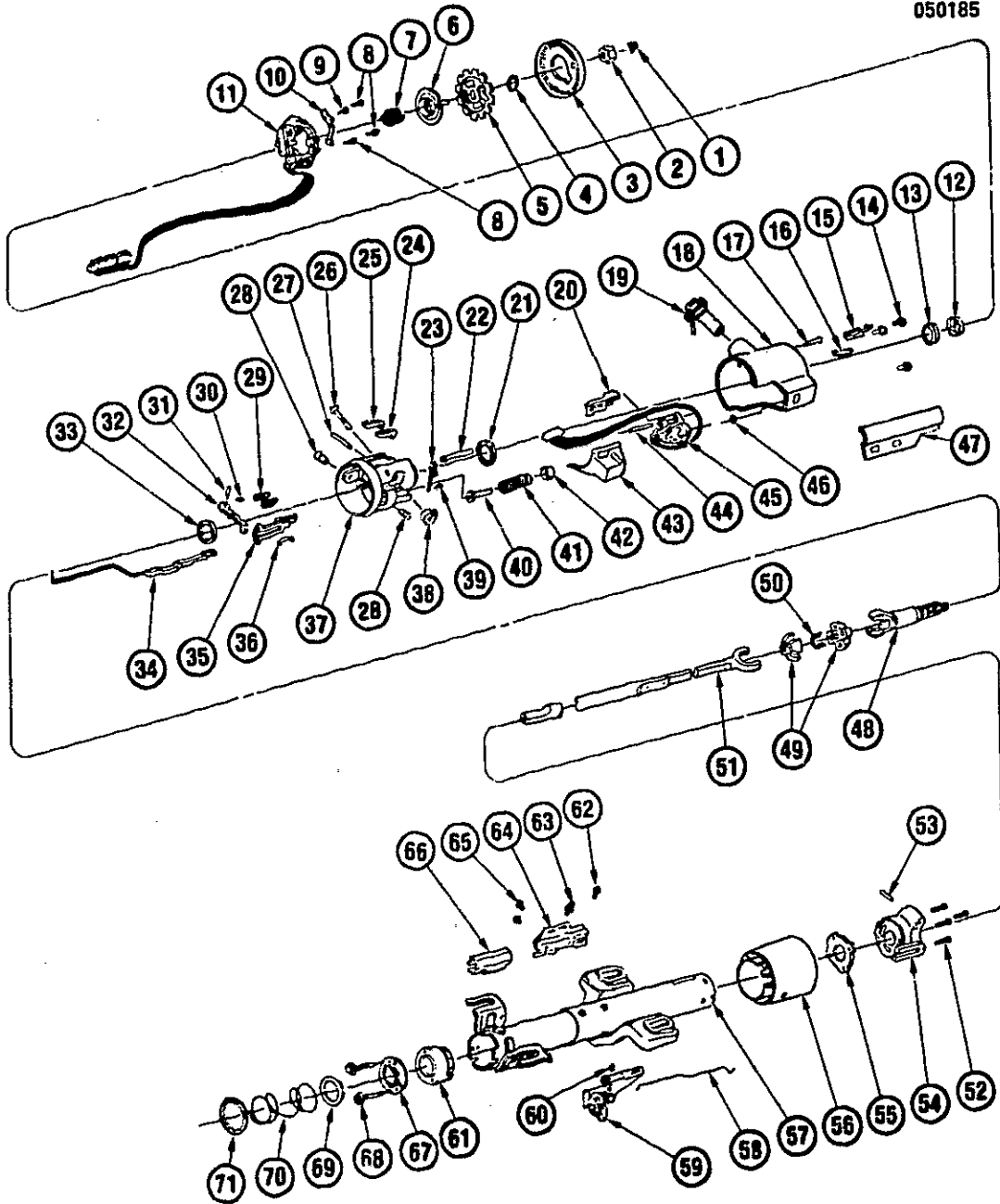

1985-1988 P STEERING COLUMN/TILT (F/S, M.T.)

1.	A12	6.515	RETAINER, STRG WHL NUT
2.		8.915	NUT, HEX (M14 X 1.5)
3.	A8	6.500	COVER, STRG SHF LK PLT
4.	N20	8.934	RING, RET
5.	A8	6.500	LOCK, STRG SHF
6.	N12	2.896	CAM, T/SIG CANC
7.	A23	6.521	SPRING, STRG COL SHF UPR BRG
8.	N12	2.895	SCREW, SWITCH MTG
9.		8.977	SCREW, RD WA HD (M4 2 X 1.41 X 20)
10.	N12	2.895	ARM, DIR SIG SW ACTR
11.	N12	2.895	SWITCH, DIR SIG
12.		N.S.	SEAT, SHF UPR BRG INNER RACE(*2)
13.		N.S.	RACE, UPR SHF UPR BRG(*2)
14.	N12	2.895	SCREW, HSG CVR
15.	N9	2.195	SWITCH, IGN KEY WARN ALARM
16.	N9	2.195	CLIP, BUZZER SW RET
17.	N9	2.195	SCREW, CYL LOCK RET
18.	A12	6.518	COVER, LK HSG
19.	N9	2.188	LOCK, IGN (CODED W/KEY)
20.	N9	2.459	ACTUATOR, DIMR SW ROD
21.		N.S.	BEARING, UPR SHF UPR (PART OF #35)
22.	A8	6.500	BOLT, SHF LK
23.		N.S.	SPRING, SHF LK BOLT (PART OF #35)
24.	A12	6.514	SHOE, LK
25.	A12	6.514	SHOE, LK
26.	N9	2.195	SHAFT, IGN SW SET DRIVE
27.	A12	6.514	PIN, TILT LK SHOE RET
28.		N.S.	PIN, PIVOT-TILT(*2)
29.	A12	6.514	SPRING, LK SHOE RETURN
30.	A12	6.514	SPRING, SHOE REL
31.	A12	6.514	PIN, SHOE REL LVR
32.	A12	6.514	LEVER, SHOE REL
33.		N.S.	BEARING, UPR SHF LWR (PART OF #35)
34.	N9	2.195	ACTUATOR, IGN SW
35.	N9	2.195	RACK KIT, IGN SW ACTR (INCLS #21.23.33.38.39)
36.	N9	2.195	SPRING, IGN SW RACK PRELOAD
37.	A12	6.514	HOUSING, TILT STRG COL
38.		N.S.	SECTOR, IGN SW ACTR (PART OF #35)
39.		N.S.	SCREW, LK SPR BOLT (PART OF #35)
40.	A23	6.521	SPRING KIT, STRG WHL TILT SPR
41.		N.S.	SPRING, WHL TILT(*2)
42.		N.S.	RETAINER, TILT SPR(*2)
43.	A12	6.518	CAP. COL HSG CVR END
44.	N9	2.459	PIN, SW ACTR PIVOT
45.	N9	2.459	SWITCH, PIVOT & PULSE(*1)
46.		N.S.	SPRING, PRELOAD (PART OF #45)
47.	N12	2.908	PROTECTOR, WIRING
48.	A23	6.524	SHAFT, W/RACE, UPR
49.	A12	6.514	SPHERE KIT, CTR (INCLS 50)
50.		N.S.	SPRING, CTR SPHERE (PART OF #49)
51.	A23	6.524	SHAFT, STRG LWR
52.	A12	6.514	SCREW, SUPT
53.		N.S.	PIN, DOWEL
54.	A12	6.518	SUPPORT, HSG
55.	A12	6.514	PLATE, SUPT LK
56.	A12	6.518	SHROUD, STRG COL HSG
57.	A12	6.518	JACKET, COL
58.	N9	2.459	ROD, DIMR SW
59.	N9	2.459	SWITCH, DIMR
60.		8.921	NUT, HEX
61.	A23	6.521	ADAPTOR, STRG SHF LWR BRG
62.	A23	6.521	SCREW, STRG COL
63.	N9	2.188	STUD, DIMMER & IGN SW MTG
64.	N9	2.188	SWITCH, IGN
65.	N9	2.188	SCREW, STRG COL IGN SW
66.	N9	2.188	HOUSING, IGN SW INHIBITOR
67.	A23	6.521	RETAINER, LWR BRG ADPT
68.		8.977	SCREW, HWH TAP (10# 16 X 3 8")
69.	A23	6.521	SEAT, LWR BRG
70.	A23	6.521	SPRING, LWR BRG
71.	A23	6.521	RETAINER, LWR SPR

NOTE 1 SEE PARTS CATALOG FOR USAGE

PONTIAC CHASSIS GROUP 7.000

ILLUSTRATION INDEX

TITLE	GRID
1984-1987 P SUSPENSION/REAR	G9
1988 P SUSPENSION/REAR	G11
1984 P BUMPER/FRONT (EXC Y82)	G13
1985 P BUMPER/FRONT (EXC WU2)	G13
1986 P BUMPER/FRONT (EXC W69)	G13
1984 P BUMPER/FRONT (Y82)	G15
1985 P BUMPER/FRONT (WU2)	G15
1986-1987 P BUMPER/FRONT (W69)	G15
1987 P37 BUMPER/FRONT (EXC W69)	G17
1988 P37 BUMPER/FRONT	G17
1988 P97 BUMPER/FRONT	G18
1984-1986 P BUMPER/REAR	G19
1987 PF37 BUMPER/REAR	G20
1987 PG97 BUMPER/REAR	G20
1988 PG97 BUMPER/REAR	G20
1987-1988 PE37 BUMPER/REAR	G21
1987-1988 PM37 BUMPER/REAR	G21

2P07-003
021690

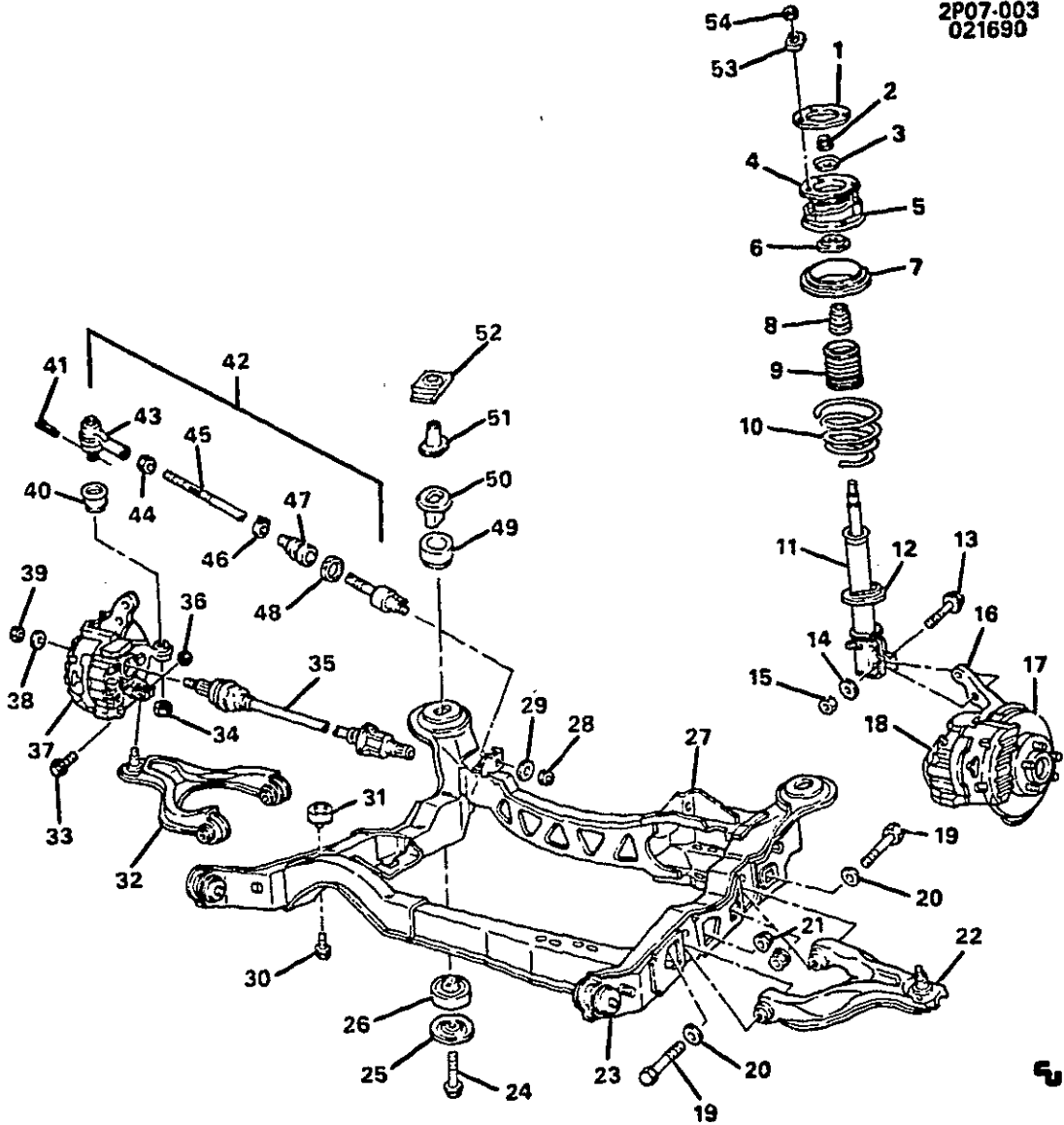

2P07-003

1984-1987 P SUSPENSION/REAR

1.	B8	7.346	REINFORCEMENT, STRUT MT (1984)	10031348
	B8	7.346	REINFORCEMENT, STRUT MT (1985-87 2 8-9)	10031348
2.	N16	5.383	NUT, RR SUSP STRUT(7 347)	14013439
3.	B8	7.347	WASHER, RR SUSP STRUT MT	10027199
4.	B9	7.396	MOUNT, RR SUSP STRUT	10031286
5.	B15	7.518	SEAT, RR SPRING	10026721
6.	B15	7.535	WASHER, RR SUSP STRUT	10026657
7.	B15	7.545	INSULATOR, RR SUSP SPRING (1984-87)	10037978
8.	N17	5.395	BUMPER, RR AXLE JOUNCE	10026720
9.	B9	7.371	SHIELD, RR SUSP STRUT DUST	10026674
10.	B15	7.503	SPRING, RR (CODE NWW)(1)	10029091
11.	B8	7.345	STRUT, RR SUSP	22049973
12.	B15	7.545	INSULATOR, FRT SPRING LWR (7 420)	14036440
13.	B8	7.347	BOLT, STRUT TO KNUCKLE	14089586
14.	B8	7.347	WASHER, RR SUSP STRUT TO KNUCKLE	14013513
15.	B8	7.347	NUT, HEX FLG PREV TORQ (M16X2X15)(10 CAD)(8 917)	12338038
16.	N20	5.808	KNUCKLE, RR BRK-LH	14076993
17.	N20	5.809	ROTOR, RR BRK	10022442
	N16	5.002	SHIELD, RR DISC BRK SPLASH	10031892
18.	N16	4.665	CALIPER, RR BRK-RH	18014437
	N16	4.665	CALIPER, RR BRK-LH	18014436
19.	N16	5.383	BOLT, HFH (M12 X 1 75 X 89)	11514112
20.	N16	5.383	WASHER, FRT SUSP CONT ARM TO FRAME	473539
21.	N16	5.383	NUT, HEX FLDG PREV TORQ (M12 X 1 75)(8 917)	11502813
22.	N16	5.382	ARM, CONT LWR-RH	10039816
23.	D7	9.023	BUSHING, FRT FRAME MTG	10029677
		8.900	BOLT, HEX (M12X1.75X200)	11504439
24.	D7	9.008	BOLT, BDY RR	14032535
	D7	9.008	BOLT, BODY RR (1987)	14032535
25.	D7	9.011	RETAINER, BDY BOLT LWR	14002114
26.	D7	9.023	CUSHION, BDY BOLT LWR	10028199
27.	N5	0.029	FRAME, ENG (1984)	10033671
	N5	0.029	FRAME, ENG (1985 EXC F41,WS6)	10033671
	N5	0.029	FRAME, ENG (1985 F41,WS6)	10033670
	N5	0.029	FRAME, ENG (1986 2 5R MD9)	10039428
	N5	0.029	FRAME, ENG (1986 2 5R MT2 W/F41)	10033670
	B8	7.003	FRAME, ENG (1986-87 MT2 EXC F41)	10033671
	N5	0.029	FRAME, ENG (1986-87 2 8-9)	10033670
	N5	0.029	FRAME, ENG (1987 2 5R W/MD9,F41)	10033670
28.	A6	6.008	NUT, HEX LOCK (M12 X 1 75)(8 917)	11500756
29.	N16	5.383	WASHER, RR AXLE TO TIE ROD LK	473539
30.		8.900	BOLT, HWH (M10 X 1 5 X 25)	
31.	N14	4.081	DAMPENER, DRIVE LINE	10036547
32.	N16	5.382	ARM, CONT LWR-LH	10039817
33.	N20	5.808	BOLT, STRG KNU CONT ARM TO KNU (6 104)	14089586
34.		8.917	NUT, HEX SLOTTED (M12 X 1 25)	14088179
35.	N17	5.420	AXLE KIT, DRIVE-RH (W/A T)(1984)	7842351
	N17	5.420	AXLE KIT, DRIVE-LH (W/A T)(1984)	7844604
	N17	5.420	AXLE KIT, DRIVE-RH (W/M T)(1984)	7844541
	N17	5.420	AXLE KIT, DRIVE-LH (W/M T)(1984)	7844671
	N17	5.420	SHAFT KIT, DR-RH (W/A T)(1985-87)	7846878
	N17	5.420	SHAFT KIT, DR-RH (W/A T)(1985-87)	7848230
	N17	5.420	AXLE KIT, DR-RH (W/M T)(1985-87)	7847103
	N17	5.420	AXLE KIT, DR-LH (W/M T)(1985-87)	7847102
	N17	5.420	SHAFT, RR AXLE-RH (W/A T)(1984)	7841389
	N17	5.420	SHAFT, RR AXLE-LH (W/A T)(1984)	7843976
	N17	5.420	SHAFT, RR AXLE-RH (W/M T)(1984)	7843185
	N17	5.420	SHAFT, RR AXLE-LH (W/M T)(1984)	7843767
	N17	5.420	SHAFT, RR AXLE-RH (W/A T)(1985-87)	7846271
	N17	5.420	SHAFT, RR AXLE-LH (W/A T)(1985-87)(6 055)	26011194
	N17	5.420	SHAFT, RR AXLE-LH (W/M T)(1985-87)(6 055)	7846170
	N17	5.420	SHAFT, RR AXLE-RH (W/M T)(1985-86)(6 055)	7846171
36.	N16	4.662	NUT, TORX PREV HWH (M10 X 1 5)(8 917)	11502812
37.	N20	5.808	KNUCKLE, RR BRK-RH	14076994
38.	N18	5.428	WASHER, RR WHL SPDL (6 056)	467146
39.	N17	5.416	NUT, RR WHL SPDL (6 022)	14009990
40.	N17	5.416	SEAL, TIE ROD & END HSG (6 242)	7828084
41.		8.938	PIN, COTTER (M3 2 X 25)	11076681
42.	N17	5.416	ROD, RR WHL SPDL	7845327
43.	N17	5.416	LINK, OTR TOE	7842318
44.		N.S.	NUT, HEX (M14 X 1 5)	
45.	N17	5.416	LINK, INR TOE	7847243
46.	N17	5.416	CLAMP, INR TOE ROD BOOT (19MM DIA)	7844100

47.	N17	5.416	SEAL, TOE LINK
48.	N17	5.416	CLAMP, TOE BOOT
49.	D7	9.023	CUSHION, BODY BOLT UPR
50.	D7	9.023	SPACER, BDY BOLT CUSH
51.		N.S.	NUT, GAGE
52.		N.S.	RETAINER
53.	N16	5.383	WASHER, RR SUSP STRUT MT
54.		8.917	NUT, HEX TORQ PREV (M8X1 25) 10 CAD

7844105
7841082
14085712
10048522

10023331
11500780

NOTE 1 SEE CHART IN GROUP FOR USAGE

2P07-009
012690

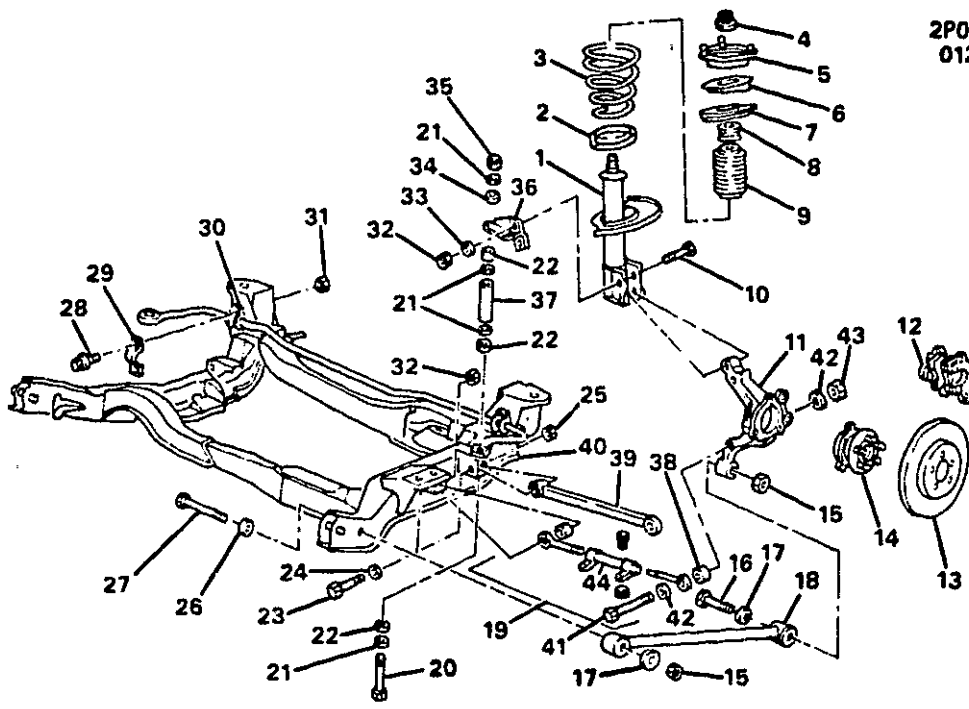

2P07-009

1988 P SUSPENSION/REAR

1.	B8	7.345	STRUT, RR SUSP	22048013
2.	B15	7.545	INSULATOR, RR SPR LWR (7 420)	14036460
3.	B15	7.503	SPRING, RR (PUD)	10053895
4.	N16	5.383	NUT, RR SUSP STRUT (7 347)	14013439
5.	B9	7.395	MOUNT, RR SUSP STRUT	14106772
6.	B15	7.518	SEAT, RR SPR (INCLS STUDS)	14106788
7.	B15	7.545	INSULATOR, RR SPR UPR	14106770
8.	B15	7.535	BUMPER, RR SUSP JOUCE	14106767
9.	B9	7.371	SHIELD, RR SUSP STRUT	14106784
10.	B8	7.347	BOLT, RR SUSP STRUT	10048447
11.	N20	5.806	KNUCKLE, RR SUSP-RH	10046494
12.	N16	4.665	CALIPER, RR DISC BRAKE-LH	3487476
	N16	4.665	CALIPER, RR DISC BRAKE-RH	3487477
13.	N20	5.809	ROTOR, BRK (MACH)	10046489
14.	N20	5.855	HUB KIT, RR SUSP (6 307)	7470002
15.		8.917	NUT, HEX PREV TORX (M14X2)(SELF FLOCK)CAD 10	11500748
16.		8.900	BOLT, HFH (M12X1 75X65)(26 6 OD)9 8 POR	11508580
17.	N16	5.383	WASHER, RR SUSP TRAILING ARM (2 8-9 W/A T MD9)	14106789
18.	N16	5.382	ARM, RR SUSP TRAILING	10053777
19.	N20	5.806	ROD, RR SUSP KNU ADJ (2 5R)(INCLS ITEMS 38 & 44)	10053723
	N20	5.806	ROD, RR SUSP KNU ADJ (2 8-9)	10053724
20.	B7	7.240	BOLT, RR STAB SHF LINK	10048448
21.		8.929	WASHER, FL (M9 1X3) 5X3 1)1010 ZC	10029761
22.	B8	7.243	GROMMET, RR STAB SHF LINK GROM	10002641
23.		8.900	BOLT, HEX (M12X1 75X70) 10 9 POR	11513938
24.	N16	5.383	WASHER, RR SUSP CONT ARM TO FRAME (0 002)	473539
25.		8.917	NUT, HEX FLGD PREV TORQ (M12X1 75)10 CA	11502813
26.	N16	5.383	WASHER, RR SUSP TRAILING ARM	14106769
27.		8.900	BOLT, HEX (M14X2X95)(37 THD)10 9 POR	11513936
28.		8.900	BOLT, HFH (M8X1 25X20) 10 9 POR	11514343
29.	B7	7.242	CLAMP, RR STAB SHF INSL	10042347
30.	B8	7.243	INSULATOR, RR STAB SHF	10097839
31.		8.917	NUT, HEX TORQ PREV (M8X1 25) 10 CAD	11500760

32.	08	7.347	NUT, RR SUSP STRUT (8 915)	12338038
33.	08	7.347	WASHER, RR SUSP STRUT TO KNUCKLE	14013513
34.	08	7.243	GROMMET, RR STAB SHF LINK GROM	10002641
35.		8.915	NUT, HEX (STYLE 1)(M8PX1 25)	
36.	B7	7.242	BRACKET, RR STAB SHF MTG-RH	10042350
	B7	7.242	BRACKET, RR STAB SHF MTG-LH	10042349
37.	B7	7.240	SPACER, RR STAB SHF LINK	10042351
38.	N20	5.806	BUSHING, RR SUSP KNU ADJ ROD (2 5R)	10053728
	N20	5.806	BUSHING, RR SUSP KNU ADJ ROD (2 8-9)	10053727
39.	N20	5.806	ROD, RR SUSP KNUCKLE	14106789
40.	B6	7.003	FRAME, RR SUSP (2 8-9 W/M T MG2. W/A T MD9)(P97.P37)	10042231
	B6	7.003	FRAME, RR SUSP (2 5R)(W/A T MD9)	10042229
41.	N16	5.380	BOLT, HEX (M12X1 75X210)(49 THD)10 9 PEOR	14106771
42.	A6	6.183	RETAINER, UPR CONT ARM BUSHING	10029804
43.		8.917	NUT, HEX (M12X1 75)(LOCK GRD 10)	11500758
44.	N20	5.806	TUBE KIT, RR SUSP KNU ADJ ROD (6 232)	7829466

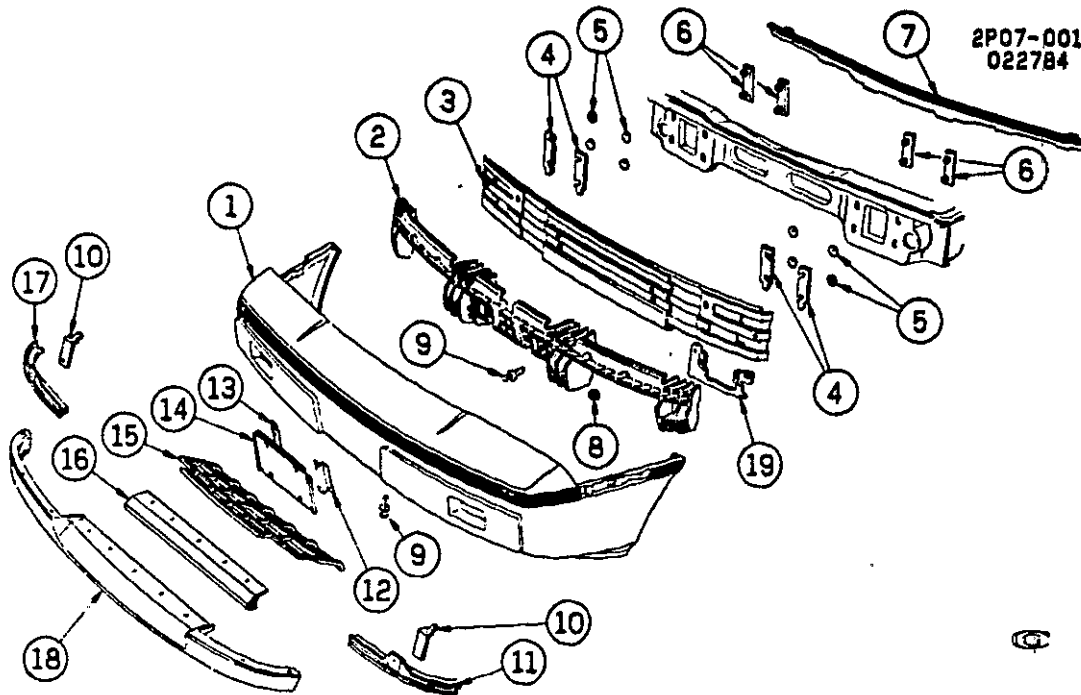

2P07-001
022784

2P07-001

**1984 P BUMPER/FRONT (EXC Y82)
1985 P BUMPER/FRONT (EXC WU2)
1986 P BUMPER/FRONT (EXC W69)**

1.	B15	7.831	FASCIA, BPR	10032432
		8.977	SCREW, HEX TAP W/WA (M4 2X1 41X16) POR	10021798
	B15	7.831	BOLT, FRT BPR FASCIA	10021799
2.	B19	7.840	ABSORBER, FASCIA ENERGY (HONEYCOMB)	18500137
	B15	7.831	BAR, IMPACT	10031925
4.	B19	7.865	SHIM, IMP BAR	10030535
5.	N20	8.934	NUT, PUSH-ON (M8 X 1.25)	
6.	B17	7.832	PLATE, IMP BAR STUD	10032476
7.	B15	7.831	REINFORCEMENT, FASCIA	10041875
		8.977	SCREW, HWH TAP (M6 3 X 1 81 X 25)	
8.		8.915	NUT, HEX STYLE (M8P X 1 25)	
9.	B15	7.831	RETAINER, PUSH-IN FASCIA (1 269)	5973400
10.	B18	7.833	BRACKET, F/END PNL DFL	10021934
		8.900	SCREW, HWH TAP (#8-18 X 1")	
11.	N8	1.269	RETAINER, F/END PNL DFL-LH	10021936
		8.977	SCREW, HWH, W/WA (M4.2X1 41X20) POR	11513801
		8.921	NUT, U-SHAPED (#8-18 THD)	
12.	B15	7.800	ADAPTER, FRT LIC BRKT-LH	10022808
		8.913	SCREW, PAN HD C/R (M6 X 1 X 20)	
		8.915	NUT, HEX (M6 X 1 X 5 5)	
		N.S.	STUD, WELD	
13.	B15	7.800	ADAPTER, FRT LIC BRKT-RH	10022805
		8.913	SCREW, PAN HD C/R (M6 X 1 X 20)	
		8.915	NUT, HEX (M6 X 1 X 5 5)	
		N.S.	STUD, WELD	
14.	B16	7.800	BRACKET, FRT LIC PLT	10024283
	B15	7.800	NUT, FRT LIC PLT	14005953
15.	N7	1.268	GRILLE, RAD	10029970
		8.977	SCREW, HWH TAP (M4 2 X 1 41 X 20)	
16.	N7	1.263	REINFORCEMENT, F/END PNL DFL (UPR & LWR)(7 833)	10031518
		8.900	SCREW, HWH (M6 X 1 X 20)	
17.	N8	1.269	RETAINER, F/END PNL DFL	10021936
		8.977	SCREW, HWH, W WA (M4 2X1 41X20) POR	
		8.900	SCREW, HWH (M6X1X20)	

17.		8.921	NUT, U SPRING (TYPE C-M6X1)	
18.	B18	7.833	DEFLECTOR, AIR DAM	10031517
	B16	7.831	RETAINER, PUSH-IN FASCIA (1 269)	5973400
19.	N11	2.587	BRACKET, P/LP-RH	10038891
	N11	2.587	BRACKET, P/LP-LH	10038892

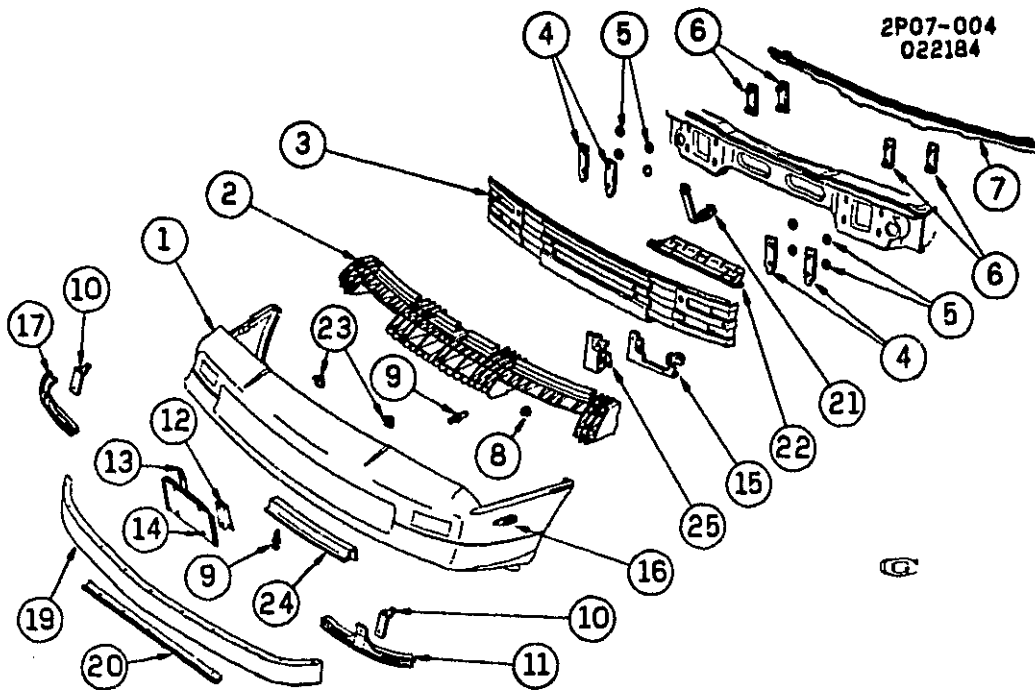

2P07-004
022184

2P07-004

**1984 P BUMPER/FRONT (Y82)
1985 P BUMPER/FRONT (WU2)
1986-1987 P BUMPER/FRONT (W69)**

1.	B15	7.831	FASCIA, BPR(*1)	10042562
		8.977	SCREW, HEX TAP W/WA (M4 2X1 41X16) POR	10021798
	B15	7.831	BOLT, FASCIA-W/CONE WA	10021799
2.	B19	7.840	ABSORBER, ENGY (1984 Y82)	16504938
	B19	7.840	ABSORBER, ENGY (1985 WU2)	16504938
	B19	7.840	ABSORBER, ENGY (1986 PM37 W/W69)	16504938
3.	B15	7.831	BAR, BPR IMPACT (1986)	10031925
	B15	7.831	BAR, BPR IMP	10040039
	B19	7.865	SHIM, IMP BAR	10030535
	N20	8.934	NUT, PUSH-ON (M8X1 25)	20453825
	B17	7.832	PLATE, IMP BAR STUD	10032478
7.	B15	7.831	REINFORCEMENT, FASCIA	10041875
		8.977	SCREW, HWH TAP W/FL WA (M6 3X1 81X20)	11508762
8.		8.915	NUT, HEX STYLE (M8X1 25)	20453825
9.	B15	7.831	RETAINER, PUSH-IN FASCIA (1 269)	5973400
10.	B18	7.833	BRACKET, F/END PNL DFL	10021934
		8.977	SCREW, HEX WA HD TAP (4 2X1 41X25)	11504591
11.	B18	7.833	RETAINER, F/END PNL DFL-LH	10030572
		8.977	SCREW, HWH TAP (M4 2X1 41X25)	11504591
		8.921	NUT, U-SHAPE MULTI THRD SPG (M6X1X6 3)	11513918
12.	B15	7.800	ADAPTER, FRT LIC BRKT	10036682
		8.900	SCREW, PAN HD C/R (M6X1X20)	11514383
		8.915	NUT, HEX (M6X1X5 5)	
		N.S.	STUD, WELD	
13.	B15	7.800	ADAPTER, FRT LIC BRKT	10036682
		8.900	SCREW, PAN HD C/R (M6X1X20)	11514383
		8.915	NUT, HEX (M6X1X5 5)	
		N.S.	STUD, WELD	
14.	B15	7.800	BRACKET, FRT LIC PLT	10037303
15.	N11	2.587	BRACKET, PARK LP-RH	10036891
	N11	2.587	BRACKET, PARK LP-LH	10036892
		8.977	BOLT, HEX W/FL WA (M6 3 X 1 81 X 20)	12337828
16.	B17	7.832	MOLDING, FASCIA-RH (1984-85)	10038511
	B17	7.832	MOLDING, FASCIA-LH (1984-85)	10038512

17.	B18	7.833	RETAINER, F END PNL DFL RH	10030871
		8.977	SCREW, HWH W/WA (M4 2X1 41X20) POR	11513801
		8.921	NUT, HEX (#8-18)	25504269
19.	B18	7.833	DEFLECTOR, F/END PNL	10031517
	B15	7.831	RETAINER, PUSH-IN FASCIA (1 269)	5973400
		8.921	NUT, HEX (#8-18)	25504269
20.	B15	7.831	REINFORCEMENT, FASCIA	10037000
21.	B15	7.831	BRACE, FRT BPR FASCIA (1 269)	10030836
22.	B18	7.833	BRACKET, FASCIA LWR DFL	10030873
23.	B15	7.831	RETAINER, FASCIA UPR FLANGE OTR (Z49)	10031635
	B15	7.831	RETAINER, FASCIA UPR FLANGE CTR (Z49)	10032366
24.	B15	7.831	REINFORCEMENT, GRL OPG	10030837
25.	B7	7.088	PAD, FRT TOWING	10037345

NOTE 1 PAINT TO MATCH

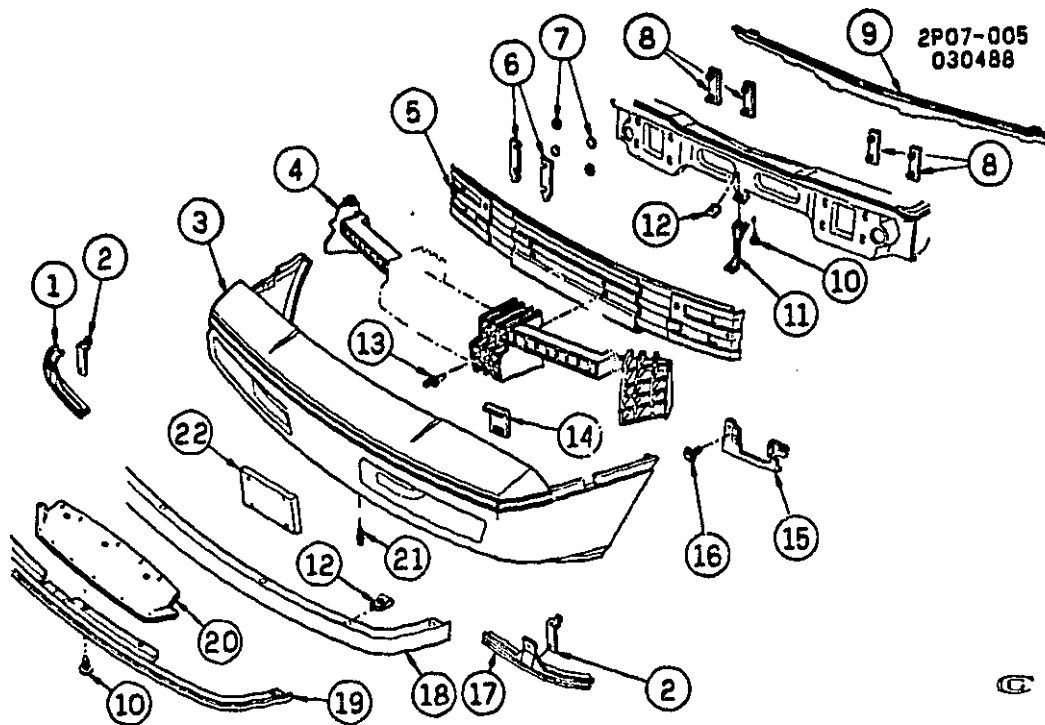

2P07-005

**1987 P37 BUMPER/FRONT (EXC W69)
1988 P37 BUMPER/FRONT**

1. B18	7.833	SUPPORT, FASCIA-RH	10040044
2. B18	7.833	BRACKET, F/END PNL DFL	10021934
3. B15	7.831	FASCIA, BPR	10055040
4. B19	7.840	ABSORBER, FRT BPR FASCIA ENGY	16507085
5. B15	7.831	BAR, BPR IMP	10040039
6. B19	7.865	SHIM, IMP BAR	10030535
7.	8.921	NUT, PUSH-ON (M8X1 25 THD) ZOR	10009923
8. B17	7.832	PLATE, BPR IMP BAR STUD	10032476
9. B15	7.831	REINFORCMENT, FASCIA	10041875
10.	8.977	SCREW, HWH, W/WA (M4 2X1 41X20) POR	11513801
11. N7	1.263	BRACE, F/END PNL DEFL	10040084
12.	8.921	NUT, U SHAPE (M4 2 X 1 41 X 065)ZOR	52351724
13. B15	7.831	RETAINER, IMP BAR (8.153)	14093088
14. B15	7.831	RETAINER, FASCIA UPR FLANGE OUTER	10031635
15. N11	2.587	BRACKET, PARK LP-RH	10036891
	2.587	BRACKET, PARK LP-LH	10036892
16.	8.977	BOLT, SEMS HWH (M6 3X1 81X20) PZOR	12337828
17. B18	7.833	SUPPORT, FASCIA-LH	10040045
18. N7	1.263	DEFLECTOR, F/END PNL	10040061
19. N7	1.263	REINFORCMENT, DEFL	10040062
20. B18	7.833	FILLER, CTR	10041861
21. B15	7.831	RETAINER, FASCIA (1 276)	20884092
22. B15	7.800	BRACKET, FRT LIC	10040047

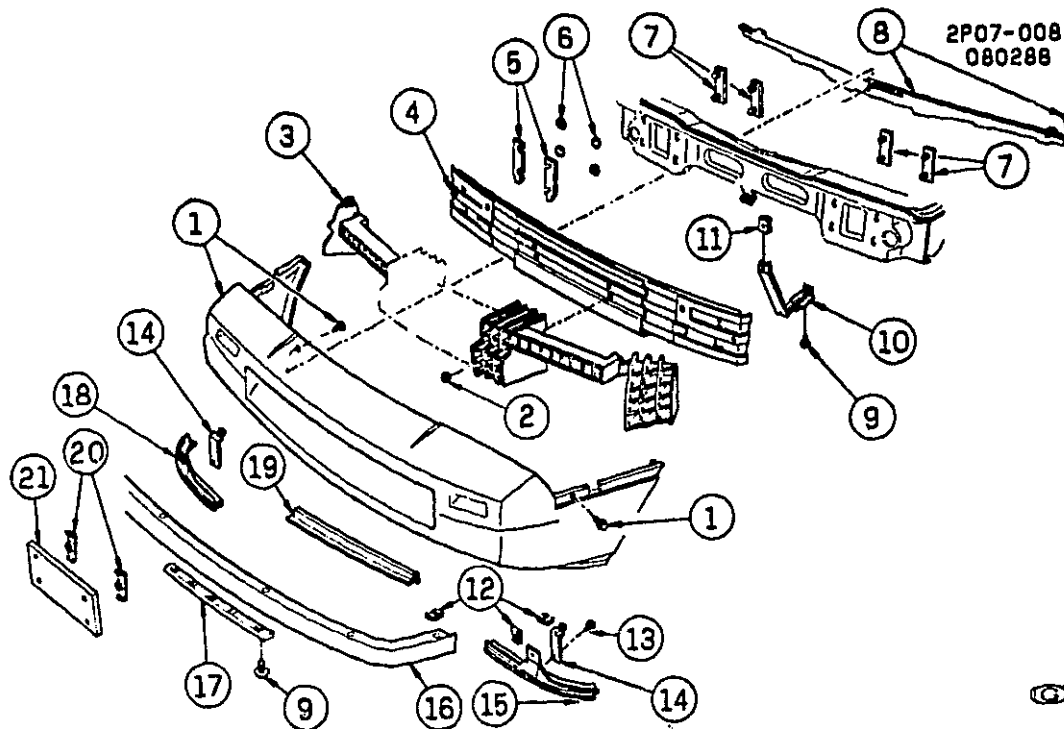

2P07-008
080288

2P07-008

1988 P97 BUMPER/FRONT

1.	B15	7.831	FASCIA, FRT BPR(*1)	10068912
		8.977	SCREW, HEX TAP W/WA (M4 2X1 41X16) POR	10021798
2.		8.917	NUT, CON TTH (M8X1 25 THD.23 5 WA)	20453625
3.	B19	7.840	ABSORBER, ENGY (HONEYCOMB)	18504938
4.	B15	7.831	BAR, BPR IMP	10040039
5.	B19	7.865	SHIM, IMP BAR	10030536
6.		8.921	NUT, PUSH-ON (M8X1 25)THD ZOR	10009923
7.	B17	7.832	PLATE, IMP BAR STUD	10032476
8.	B15	7.831	REINFORCEMENT, FASCIA	10041875
		8.977	SCREW, HWH TAP W/FL WA (M6 3X1 81X20)SS BLK	11508762
9.		8.977	SCREW, HWH W/WA (M4 2X1 41X20) POR	11513801
10.	B15	7.831	BRACE, FASCIA	10030838
11.		N.S.	NUT, SPRING (#8-18)	
12.		8.921	NUT, U-SHAPE (M4 2X1 41)ZOR	52351724
13.		8.977	SCREW, HWH TAP (M4 2X1 41X25)(10 783)	1840810
14.	B18	7.833	BRACKET, FASCIA	10021934
15.	B18	7.833	RETAINER, FASCIA LWR DFL-LH	10030672
16.	B18	7.833	DEFLECTOR, FRT END PNL	10030870
17.	B15	7.831	REINFORCEMENT, FASCIA (LWR DFL)	10037000
18.	B18	7.833	RETAINER, FASCIA LWR DFL-RH	10030671
19.	B15	7.831	REINFORCEMENT, FRT BPR FASCIA	10030837
20.	B15	7.800	ADAPTER, FRT LIC BRKT	10038682
21.	B15	7.800	BRACKET, FRT LIC	10037303

NOTE 1 PAINT AS REQUIRED

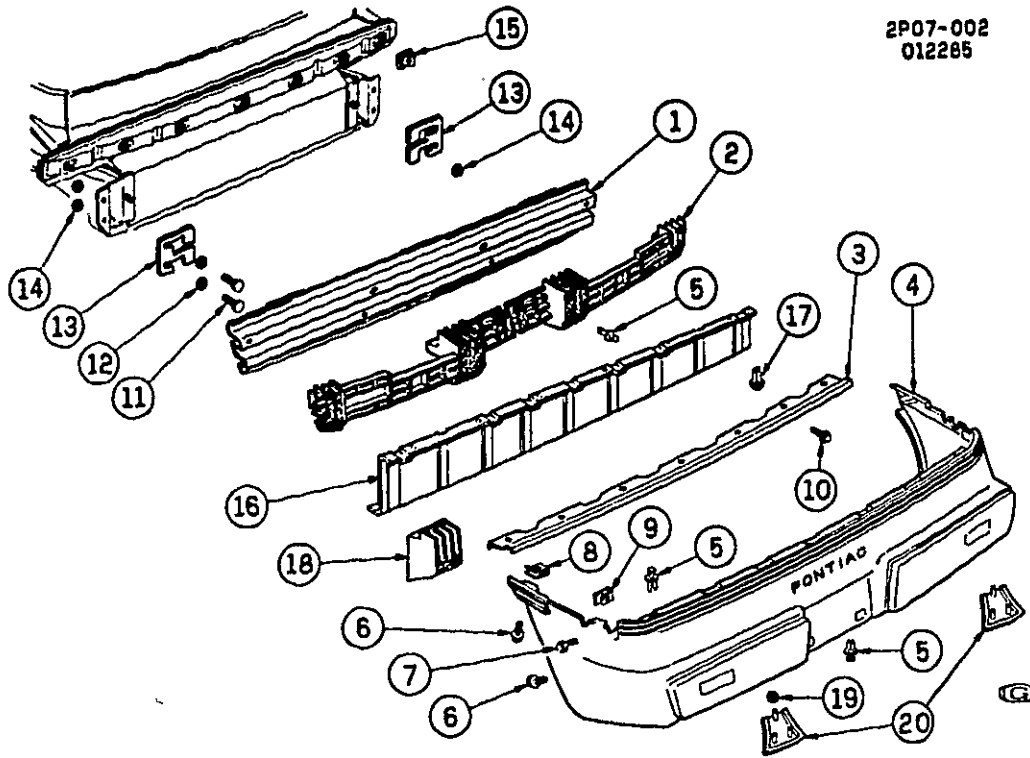

2P07-002

1984-1986 P BUMPER/REAR

1.	B15	7.831	BAR, RR BPR IMP	10031924
2.	B19	7.840	ABSORBER, RR BPR	16503952
3.	B15	7.831	SUPPORT, RR BPR FASCIA	10020479
4.	B15	7.831	FASCIA, RR BPR (1984 EXC Y82)(* 1)	10032433
	B15	7.831	FASCIA, RR BPR (1984 Y82)	10042563
	B16	7.831	FASCIA, RR BPR (1985-86 W/2 5R)(* 1)	10032433
	B15	7.831	FASCIA, RR BPR (1985 2 8-9 EXC WU2)	10033958
	B15	7.831	FASCIA, RR BPR (1986 2 5R EXC W69)	10032433
5.	B15	7.831	RETAINER, PUSH-IN FASCIA (1 269)	5973400
6.		8.977	SCREW, HWH (M4 2 X 1 41 X 16)	
7.	B15	7.831	BOLT, RR BPR FASCIA	10021799
8.		8.921	NUT, U-SHAPE SPR (M4 2 X 1 41)	
9.		8.921	NUT, U-SHAPE (#8 - 18)	
10.		8.900	SCREW, HWH (M6 X 1 X 20)	
11.	B19	7.874	BOLT, RR BPR BAR	10016808
12.	N20	8.934	NUT, PUSH-ON (M8 X 1 25)	
13.	N5	0.000	SHIM,	
14.		8.917	NUT, HWH (M8 X 1 25)	
15.		8.921	NUT, U SHAPE SPR (M6 X 1)	
16.	B15	7.831	BRACKET, FASCIA TO BAR (1984 Y82)	10030875
	B15	7.831	BRACKET, RR BPR FASCIA TO BAR (1985 W/WU2)	10030875
	B15	7.831	BRACKET, RR BPR FASCIA TO BAR (1986 P97)	10030875
17.	C7	8.153	RETAINER, BRKT TO ABSORBER (1 276)	20864092
18.	B7	7.068	PAD, RR TOW (Y82)	10036196
		8.900	BOLT, HEX (M8X1 25X30) 9 8 PZOR	
		8.917	NUT, HEX FLG (M8-1 25)	
		8.921	NUT, HFH (M5X15)	
19.		7.831	SHIELD, HEAT-RH (1984 Y82)	10037001
	B15	7.831	SHIELD, HEAT-LH (1984 Y82)	10037002
	B15	7.831	SHIELD, RR BPR FASCIA HT-RH (1985 W/WU2)	10040021
	B15	7.831	SHIELD, RR BPR FASCIA HT-LH (1985 W/WU2)	10040022
	B15	7.831	SHIELD, RR BPR FASCIA HT-RH (1986 P97)	10039516
	B15	7.831	SHIELD, RR BPR FASCIA HT-LH (1986 P97)	10039517

NOTE 1 PAINT TO MATCH

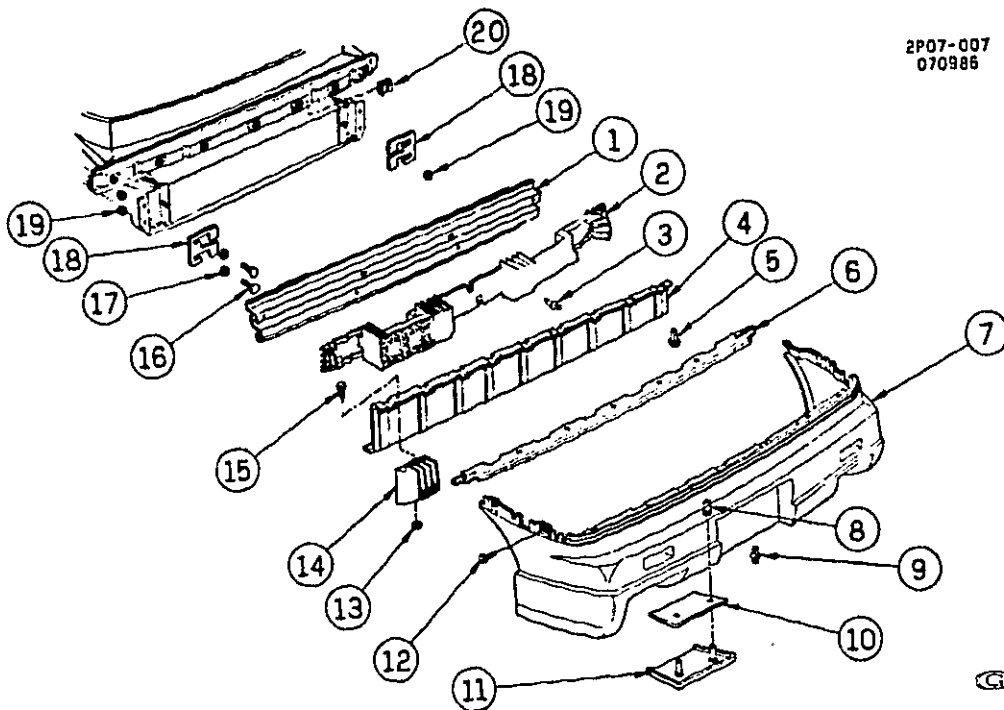

2P07-007

**1987 PF37 BUMPER/REAR
1987 PG97 BUMPER/REAR
1988 PG97 BUMPER/REAR**

1.	B15	7.831	BAR, RR BPR IMP	10031924
2.	B19	7.840	ABSORBER, ENGY	16503952
3.	B15	7.831	RETAINER, PUSH-IN FASCIA (1 269)	5973400
4.	B16	7.831	BRACKET, FASCIA TO BAR (P97)	10030675
5.	C7	8.1F3	RETAINER, FASCIA BRKT (1 276)	20864092
6.	B15	7.831	SUPPORT,W/BRACKET BPR FASCIA (P97)	10055079
7.	B16	7.831	FASCIA, RR BPR (1987 P97)(*1)	10088913
	B15	7.831	FASCIA, RR BPR (1987 P37)(W/W69)(*1)	10042563
	B15	7.831	FASCIA, RR BPR (1988 P97)(*1)	10088913
8.		8.917	NUT, HEX W/CON WA (M6X1) 9 PEOR	11508277
9.	C7	8.153	RETAINER, RR BPR FASCIA BRKT (1 276)	20864092
10.	B15	7.831	SPACER, RR BPR FASCIA	10051833
11.	B15	7.831	SHIELD, FASCIA HT-RH (P97)	10039516
	B15	7.831	SHIELD, FASCIA HT-LH (P97)	10039517
	B15	7.831	SHIELD, RR BPR FASCIA HT-RH (P37 W/W69)	10040022
	B15	7.831	SHIELD, RR BPR FASCIA HT-LH (P37 W/W69)	10040021
12.		8.977	SCREW, HEX TAP W/WA (M4 2X1 41X16) POR	10021798
13.		8.917	NUT, HFH (M8-1 25) 9 8 PC	11507036
14.	B7	7.068	PAD, RR TOWING	10038198
15.		8.900	SCREW, HEX (M8X1 25X30) 9 8 PZOR	11508269
16.	B19	7.874	BOLT, RR BPR IMP BAR	10018808
17.		8.921	NUT, PUSH-ON (M8X1 25)	10009923
18.	B19	7.866	SHIM, RR BPR IMP BAR	10030536
19.		8.916	NUT, HWH (M8X1 25)	20453825
20.		8.921	NUT, U-SHAPE MULTI THRD SPG (M6X1X6 3)	11513918

NOTE 1 PAINT TO MATCH

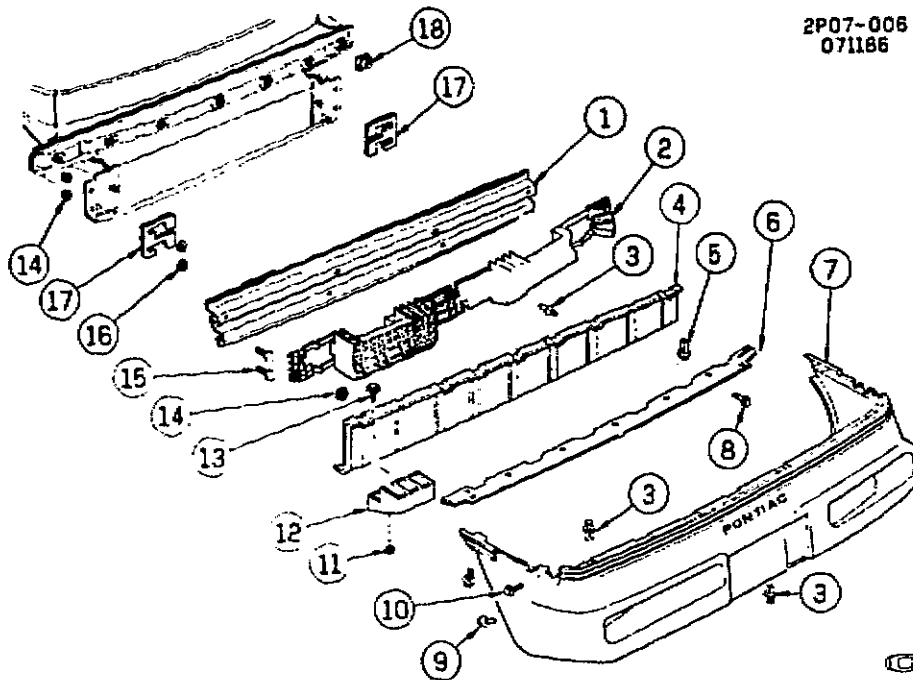

2P07-006

**1987-1988 PE37 BUMPER/REAR
1987-1988 PM37 BUMPER/REAR**

1.	B15	7.831	BAR, RR BPR IMP (PM37 EXC W69)	10040039
	B15	7.831	BAR, RR BPR IMP (PM37 W/W69)	10031924
2.	B19	7.840	ABSORBER, ENRGY (HONEYCOMB)(PM37 W/W69)	16503952
3.	B15	7.831	RETAINER, PUSH-IN FASCIA (1 289)	5973400
4.	B15	7.831	BRACKET, FASCIA TO BAR (PM37 W/W69)	10030875
5.	C7	8.153	RETAINER, FASCIA BRKT (1 276)	20864092
6.	B15	7.831	SUPPORT, W/BRACKET RR BPR FASCIA	10055079
7.	B15	7.831	FASCIA, RR BPR (P37 2 5R EXC W69)	10055053
	B15	7.831	FASCIA, RR BPR (P37 W/W69)	10042583
8.		8.900	SCREW, HWH (M6X1X20) 9 8	11514383
9.		8.977	SCREW, HWH (M4 2X1 41X16)	11503551
10.	B15	7.831	BOLT, FASCIA-W/CONE WA	10021799
11.		8.917	NUT, HEX FLG (M8-1 25) 9 8 PC	11507038
12.	B7	7.088	PAD, RR TOW (PM37 W/W69)	10036198
13.		8.800	SCREW, HEX (M8X1 25X30) 9 PZOR	11508269
14.		8.915	NUT, HEX (M8X1 25)	20453825
15.	B19	7.874	BOLT, BPR IMP BAR	10018808
16.		8.921	NUT, PUSH-ON (M8X1 25) ZOR	10088923
17.	B19	7.886	SHIM, IMP BAR	10030538
18.		8.921	NUT, U-SHAPE MULTI THRD SPG (M6X1X6 3)	11513918

PONTIAC CHASSIS GROUP 8.000

ILLUSTRATION INDEX

TITLE	GRID
1984-1986 P MOLDINGS/FRONT END	H4
1987 PG97 MOLDINGS/FRONT END	H5
1987-1988 PM37 MOLDINGS/FRONT END (EXC W89)	H5
1987-1988 PF37 MOLDINGS/FRONT END	H6
1987-1988 PG97 MOLDINGS/FRONT END	H6
1984 P SHEET METAL/FRONT END (EXC Y82)	H8
1985 P SHEET METAL/FRONT END (EXC WU2)	H8
1986 P37 SHEET METAL/FRONT END (EXC W89)	H8
1984 P SHEET METAL/FRONT END (Y82)	H11
1985 P SHEET METAL/FRONT END (WU2)	H11
1986-1988 PG97 SHEET METAL/FRONT END	H14
1986-1988 PM37 SHEET METAL/FRONT END (W89)	H14
1987-1988 P37 SHEET METAL/FRONT END	H17
1984 P SPARE WHEEL STOWAGE & JACK PARTS (EXC Y82)	H19
1984 P SPARE WHEEL STOWAGE & JACK PARTS (Y82)	H20
1985-1988 P SPARE WHEEL STOWAGE & JACK PARTS	H21
1984-1988 P HEATER & DEFROSTER SYSTEM (C41)	H23
1984-1988 P HEATER & BLOWER ASM	H25
1984-1986 P HOSES & PIPES/HEATER	H27
1987-1988 P HOSES & PIPES/HEATER	I 3
1985-1988 P HEATER CONTROL ASM	I 4

2P08-002
070783

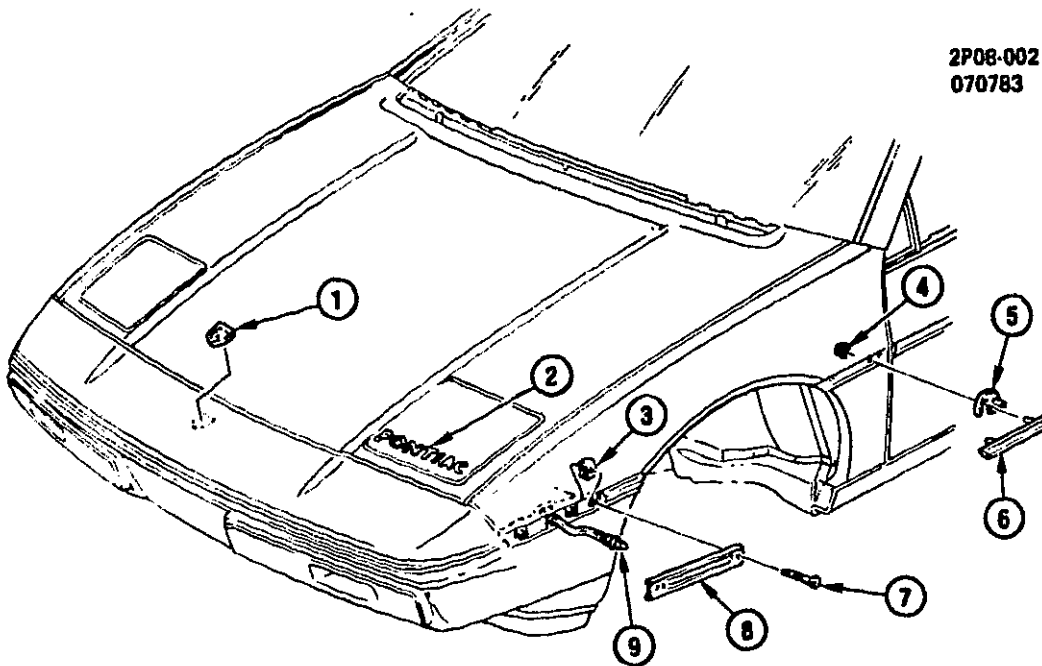

2P08-002

1984-1986 P MOLDINGS/FRONT END

1.	B17	7.832	EMBLEM, BPR FASCIA "FIERO" (1984 EXC Y82)	10030186
	B17	7.832	EMBLEM, BPR FASCIA "FIERO" (1984 Y82)	10032011
	B17	7.832	EMBLEM, BPR FASCIA "FIERO" (1985)	10030188
	B17	7.832	EMBLEM, BPR FASCIA "FIERO" (1986 P37)	10040813
2.	N11	2.770	PANEL, "PONTIAC" (STAMPED IN LH PANEL)	20302393
3.		8.921	NUT, U SHAPED (#8-18)	1835216
4.		8.921	NUT, FACETED FLG W/SLR (M6 X 1) ZOR	11505886
5.	C7	8.133	CLIP, FDR MLDG (PART OF 6)	20598116
6.	C7	8.132	MOLDING KIT, FDR RR OF WHL OPG CTR-RH	12327901
	C7	8.132	MOLDING KIT, FDR RR OF WHL OPG CTR LH	12327902
7.		8.977	SCREW, PN TORX TAP (M4 2 X 1.41 X 30)	11505836
8.	N11	2.575	LAMP, FRT SI MKR-RH	920058
	N11	2.575	LAMP, FRT SI MKR LH	920057
9.	N11	2.575	SOCKET, SI MKR LP	12083460

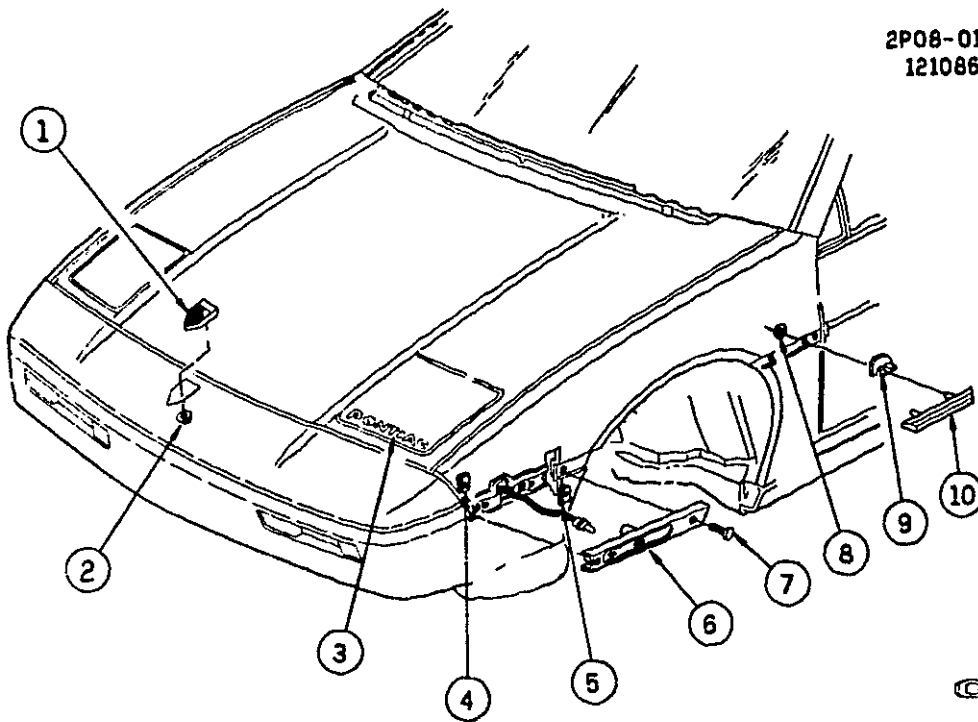

2P08-013

**1987 PG97 MOLDINGS/FRONT END
1987-1988 PM37 MOLDINGS/FRONT END (EXC W69)**

1.	B17	7.832	EMBLEM, F/END FASCIA "FIERO"(P37)	10040813
	B17	7.832	EMBLEM, FRT BPR FASCIA "GT"(P97)	10036681
2.		8.921	NUT, MET STAMPED (5 MM ID)	11501793
3.	N11	2.770	PANEL, HDLP CVR-LH "PONTIAC"	20302393
4.		8.921	NUT, U TYPE (M4 2X1 41) POR	1635216
5.		8.921	NUT, U SHAPE (M4 2X1 41) ZOR	52351724
6.	N11	2.575	LAMP, FRT SI MKR-RH (P37 EXC W69)	5974302
	N11	2.575	LAMP, FRT SI MKR-LH (P37 EXC W69)	5974301
	N11	2.575	LAMP, FRT SI MKR-RH (P97)	5974302
	N11	2.575	LAMP, FRT SI MKR-LH (P97)	5974301
7.		8.977	SCREW, PAN HD TORX TAP (M4 2X1 41X30) SS	11505835
8.		8.921	NUT, HEX STAMPED W/SLR (M6X1X24 OD) ZOR	11505865
9.	C7	8.133	CLIP, MLDG FDR CTR RR	20598116
10.	C7	8.132	MOLDING KIT, FDR RR OF WHL OPG CTR-RH (BLA)(P37)	12327901
	C7	8.132	MOLDING KIT, FDR RR OF WHL OPG CTR-LH (BLA)(P37 W/B97)	12327902
	C7	8.132	MOLDING KIT, FDR RR-RH (BLA)(P97 EXC B97)	12327903
	C7	8.132	MOLDING KIT, FDR RR-LH (BLA)(PM97 EXC B97)	12327904

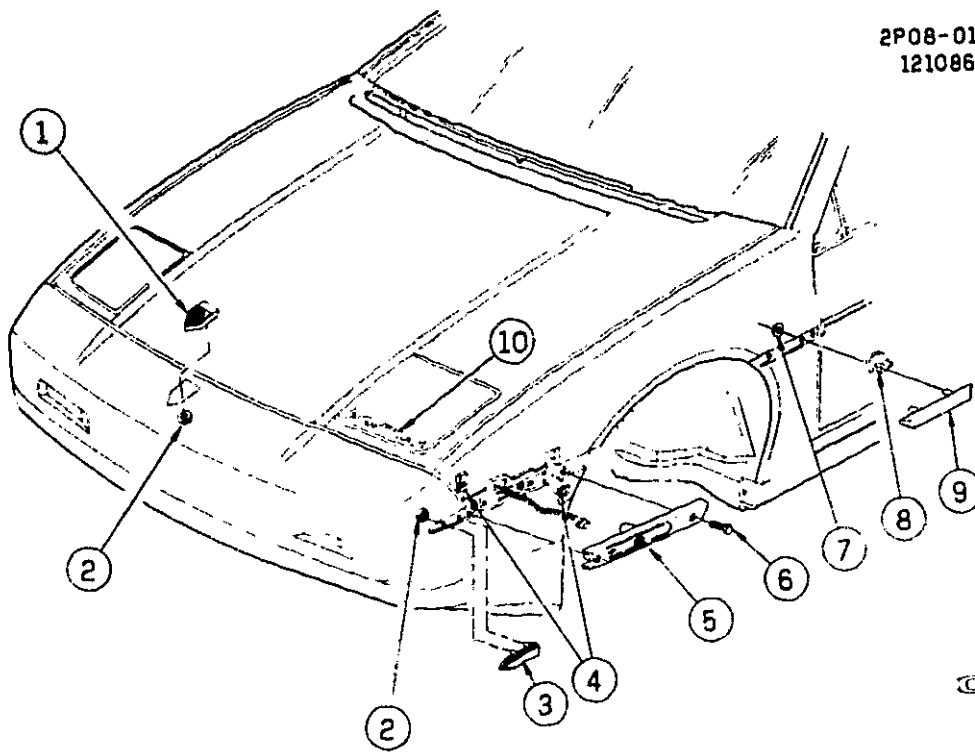

2P08-014

**1987-1988 PF37 MOLDINGS/FRONT END
1987-1988 PG97 MOLDINGS/FRONT END**

1.	B17	7.832	EMBLEM, FRT BPR FASCIA "GT" (P97)	10038681
	B17	7.832	EMBLEM, F/END FASCIA "FIERO" (P37)	10040813
2.		8.921	NUT, MET STAMPED (5 MM ID)	11501793
3.	B17	7.832	MOLDING, FASCIA-RH (P97)	10035764
	B17	7.832	MOLDING, FASCIA-LH (P97)	10035765
	B17	7.832	MOLDING, FASCIA-RH (W/W69)	10038511
	B17	7.832	MOLDING, FASCIA-LH (W/W69)	10038512
4.		8.921	NUT, U-TYPE (M4 2X1 4 1) PZOR	1635216
5.	N11	2.575	LAMP, FRT SI MKR-RH (P37 EXC W69)	5974302
	N11	2.575	LAMP, FRT SI MKR-LH (P37 EXC W69)	5974301
	N11	2.575	LAMP, FRT SI MKR-RH (P97)	5974302
	N11	2.575	LAMP, FRT SI MKR-LH (P97)	5974301
	N11	2.575	SOCKET, FRT SI MKR LP	12083480
6.		8.977	SCREW, PAN HD TORX TAP (M4 2X1 4 1X30) SS	11505835
7.		8.921	NUT, HEX STAMPED W/SLR (M6X1) ZOR	11505885
8.	C7	8.133	CLIP, MLDG FDR CTR RR	20595116
9.	C7	8.132	MOLDING KIT, FDR RR OF WHL OPG CTR-RH (P37)(BLA)	12327901
	C7	8.132	MOLDING KIT, FDR RR OF WHL OPG CTR-LH (P37 W/B97)(BLA)	12327902
10.	N11	2.770	PANEL, HDLP CVR-LH "PONTIAC"(STMPD IN PANEL)	20302393

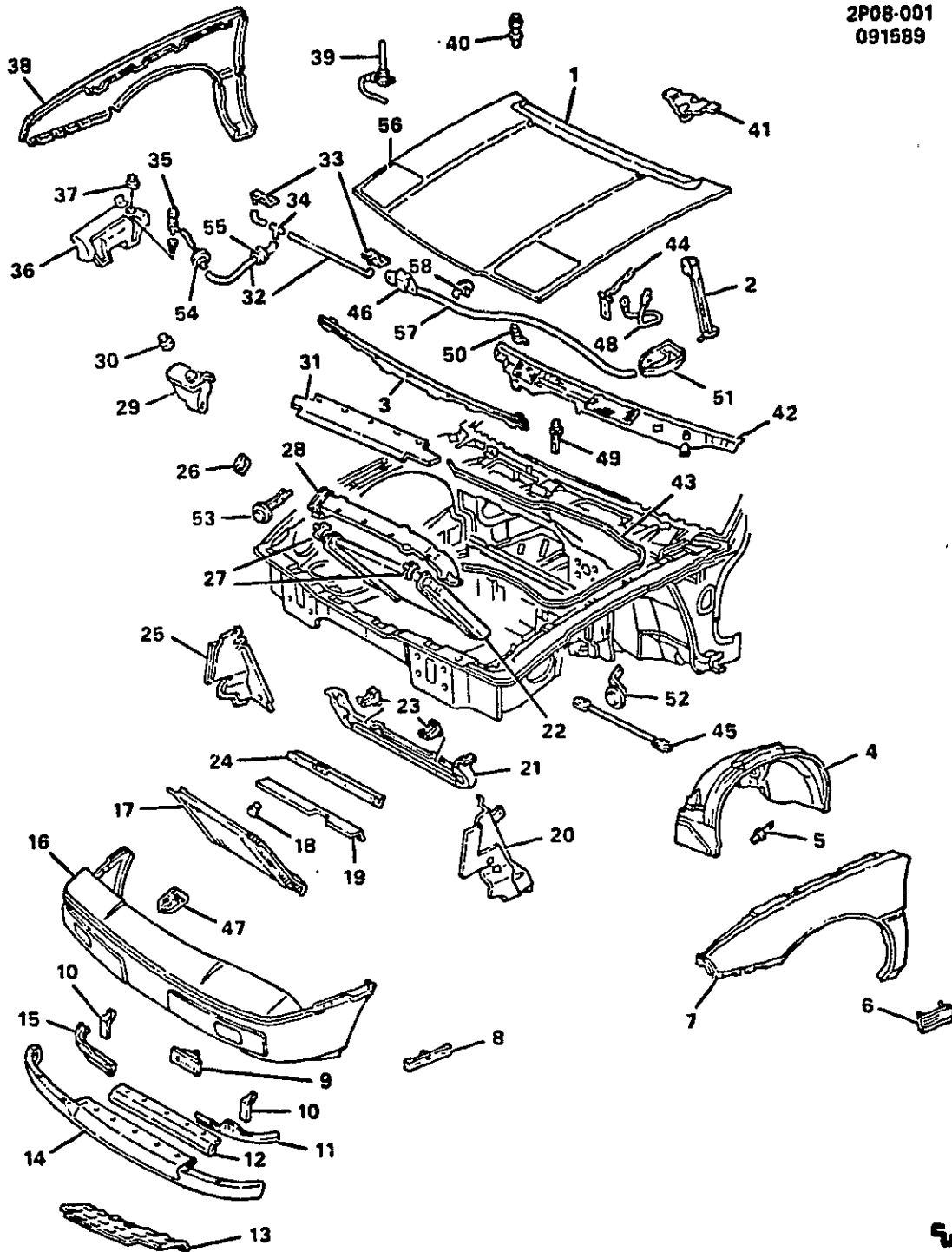

**1984 P SHEET METAL/FRONT END (EXC W82)
1985 P SHEET METAL/FRONT END (EXC WU2)
1986 P37 SHEET METAL/FRONT END (EXC W69)**

1.	C6	8.000	HOOD(*4)	20816584
	C6	8.015	REINFORCEMENT, COMPT LID AT HOLD OPEN	20381226
2.	C6	8.015	SUPPORT, COMPT LID	20379386
3.	B15	7.831	REINFORCEMENT, BPR FASCIA	10041875
4.	C7	8.153	PANEL, WHL HSG LNR-RH	12392684
	C7	8.153	PANEL, WHL HSG LNR-LH	12392685
5.	N26	12.944	RETAINER, W/H LNR (1 276)	20864092
6.	C7	8.132	MOLDING KIT, FDR RR-RH (W/B97)	12327901
	C7	8.132	MOLDING KIT, FDR RR-LH (W/B97)	12327902
	C7	8.133	CLIP, MLDG FDR CTR RR	20596116
		8.921	NUT, HEX STMP (M6X1)	11505885
7.	C6	8.130	PANEL,F/FDR (DRILL AS REQ'D)(H*3)	20572975
	C7	8.133	RIVET, FDR TO BODY SI FRM (12 934)	20375100
8.	N11	2.575	LAMP, SI MKR-RH	920058
	N11	2.575	LAMP, SI MKR-LH	920057
	N11	2.575	SOCKET, SI MKR LP	12083460
9.	N11	2.585	LAMP, PK AND T/SIG-RH	917328
	N11	2.585	LAMP, PK AND T/SIG-LH	917327
	N11	2.598	SOCKET, PK & T/SIG LP	12013813
10.	B18	7.833	BRACKET, PNL DEFL	10021934
11.	N8	1.269	RETAINER, PNL DFL-LH	10021936
12.	N7	1.263	REINFORCEMENT, PNL DEFL	10031518
13.	N7	1.266	GRILLE, RAD	10029970
14.	B18	7.833	DEFLECTOR, PNL AIR DAM	10031517
15.	N8	1.269	RETAINER, PNL DEFL-RH	10021936
16.	B15	7.831	FASCIA, BPR(*3)	10032432
17.	D18	9.190	CONDENSER, A C	3050988
18.	D19	9.242	NUT (M6X1)	10027795
19.	N8	1.274	SEAL, RAD AIR LWR TO CNDSR	10023641
20.	N8	1.272	BAFFLE, RAD AIR-LH (W/C60)	10021479
	N8	1.272	BAFFLE, RAD AIR-LH (EXC C60)	10027191
21.	N8	1.270	PANEL, RAD MT LWR	10041205
22.	N7	1.219	RADIATOR (CODES MB.MX.MC.MYX1985-86)(W/V08)(*1)	3057621
	N7	1.219	RADIATOR (CODES MB.MX.MC.MYX1984)(EXC V08)(*1)	3057621
23.	N8	1.270	INSULATOR, RAD MT LWR	10021371
24.	N8	1.274	SEAL, RAD AIR LWR TO RAD LWR PNL	10023647
25.	N8	1.272	BAFFLE, RAD AIR-RH	10021372
26.	N7	1.203	CAP, RAD FIL	10038879
27.	N8	1.270	INSULATOR, RAD MT UPR	10021536
28.	N8	1.270	PANEL, RAD MT UPR	10055019
29.	N7	1.240	RESERVOIR, CLNT RECOVERY	10038923
30.	N7	1.240	CAP, CLNT RECOVERY RESVR	15630112
31.	N8	1.274	SEAL, RAD AIR UPR	10021482
32.		8.962	HOSE, WSW (5/32")	
33.	E12	10.156	NOZZLE, WSWA	10024266
34.		8.963	TEE, CONN (3/16" DIA HOSE)	
35.	E12	10.153	PUMP, WSWA	22039339
36.	E12	10.154	CONTAINER, WSWA SOLV (1984-85)	22039340
	E12	10.154	CONTAINER, WSWA SOLV (1986)	22082599
37.		N.S.	CAP, WSWA SOLV CNTNR	
38.	C6	8.130	PANEL, RH	10077314
39.	D20	9.647	CABLE, ANT	10031602
	D20	9.647	ANTENNA, RDO W/TUBE FIXED	10149422
	D20	9.647	INSULATOR, RDO ANT	10036925
		8.977	SCREW, HWH THD (M4 2X1 41X13)	
	D20	9.647	INSULATOR, RDO ANT	10036925
40.	C6	8.015	BOLT, HOOD CAT (1984-85)	367499
	C6	8.015	BOLT, HOOD CAT (1986)	20816588
41.	C6	8.080	STRIKER, LK COMPT	20484234
	C6	8.080	SEAL, WAT COMPT LK AT C L	20469036
	C6	8.080	NUT, COMPT LID STKR TO PNL	20460928
42.	N21	12.800	SCREEN, SHRD TOP VENT (1984-85)	20559921
	N21	12.800	SCREEN, SHRD TOP VENT (1986)	10074271
43.	C6	8.010	WEATHERSTRIP, COMPT (12 269)	20880008
44.	C6	8.015	HINGE, COMPT-RH	20594604
	C6	8.015	HINGE, COMPT-LH	20594605
45.	B6	7.006	BRACE, LWR STRUCTURE BODY RL	10032967
46.	C6	8.080	LOCK, COMPT LID & ACTR (INCL 57 58)	20369893
47.	B17	7.832	EMBLEM, BPR FASCIA (1984-85)	10030188
	B17	7.832	EMBLEM, BPR FASCIA (FIERO)(1986)	10040813
48.		N.S.	WIRE, RDO GRD	

48.		0.965	TERMINAL, 59 SERIES MALE 12 GA	20545277
49.	N21	12.243	SWITCH, COMPT LID AJAR (1985 86X11 950)	20472201
50.	C8	0.083	SPRING, HOOD POP-UP	20318498
51.	C8	0.075	HANDLE, COMPT	10024319
52.	N11	2.810	HORN, 455HZ	10024318
53.	N11	2.810	HORN, 352HZ	26523494
54.	E12	10.153	VALVE, WSWA CHK	20344290
55.	E12	10.154	GROMMET, WSWA HOSE (TO FRT OF DASH)	20302392
56.	N11	2.770	PANEL, HDLP CVR-RH	20302393
	N11	2.770	PANEL, HDLP CVR-LH	20351013
57.	N21	12.242	CABLE, CONN COMPT LID LK (PART OF 46)	1233599
58.	C6	0.080	CLIP, COMPT LID LK STKR (2 559)(PART OF 46)	

NOTE 1 SEE CHART IN GROUP FOR USAGE

NOTE 3 PAINT TO MATCH

NOTE 4 COMPONENTS SERVICED

2P08-007
121086

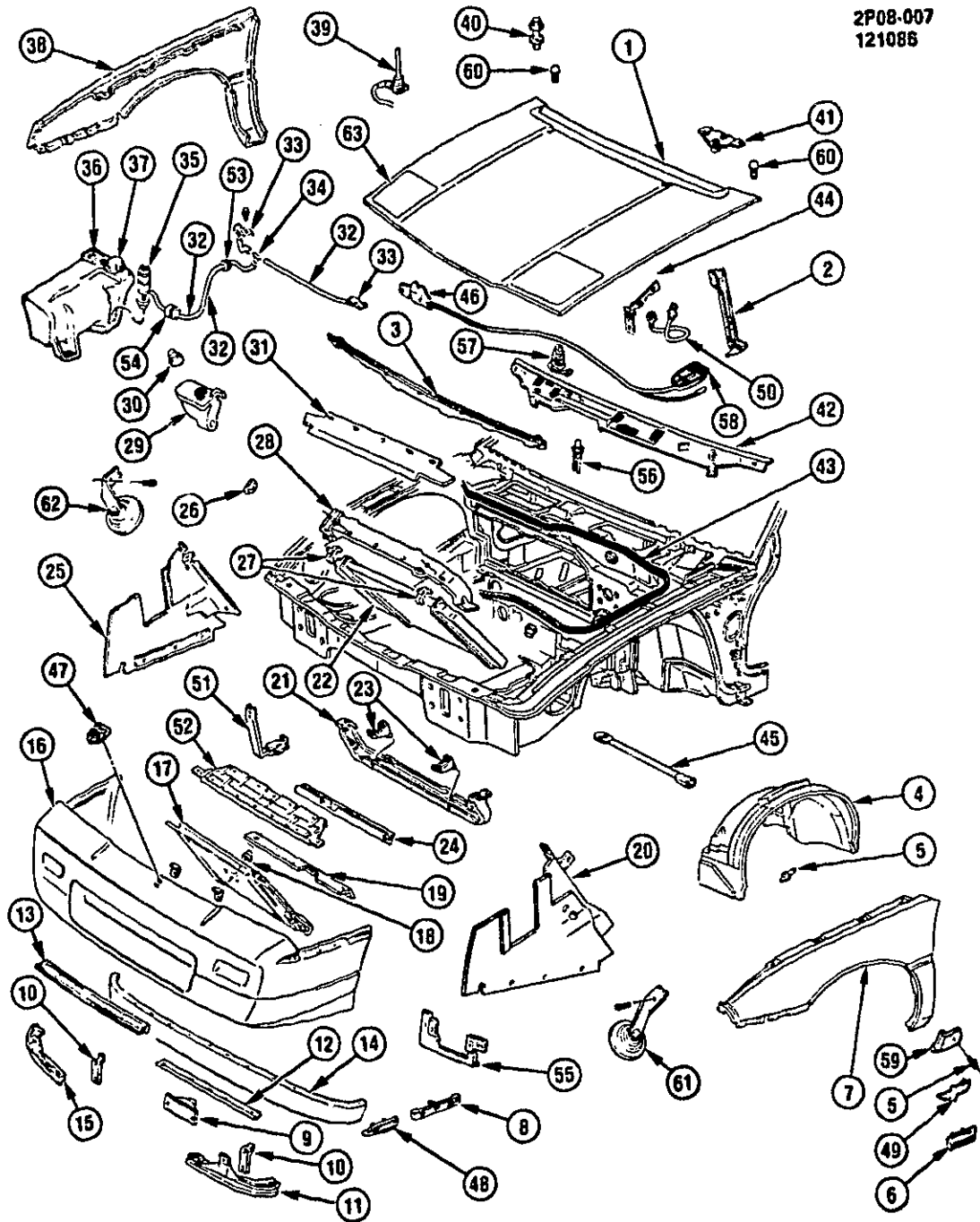

2P08-007

**1984 P SHEET METAL/FRONT END (Y82)
1985 P SHEET METAL/FRONT END (WU2)**

1.	C6	8.000	HOOD	20816564
2.	C6	8.015	SUPPORT, FRT COMPT LID	20379366
3.	B15	7.831	REINFORCEMENT, FRT BPR FASCIA	10041875
4.	C7	8.153	LINER, WHL HSE LNR FRT-RH	10077494
	C7	8.153	LINER, WHL HSE LNR FRT-LH	10077495
5.	N23	12.934	RETAINER, WHL HOUSE INR PNL TO FRAME (1 276)	20864092
6.	C7	8.132	MOLDING KIT, FDR RR OF WHL OPG .RH (BLA)	12327901
	C7	8.132	MOLDING KIT, FDR RR OF WHL OPG .LH (BLA)	12327902
7.	C6	8.130	PANEL, F/FDR-LH(*2)	20572975
	C7	8.133	RIVET, FDR TO BODY SI FRAME (12 934)	20375100
8.	N11	2.575	LAMP, FRT SI MKR-LH	920057
	N11	2.575	LAMP, FRT SI MKR-RH	920058
9.	N11	2.585	LAMP, PK AND T/SIG-LH	917327
	N11	2.585	LAMP, PK AND T/SIG-RH	917328
	N11	2.575	SOCKET, SI MKR LP	12083460
10.	B18	7.833	BRACKET, F/END PNL DFL	10021934
11.	B18	7.833	RETAINER, F/END PNL DFL-LH	10030672
12.	B15	7.831	REINFORCEMENT, FRT BPR FASCIA LWR DFL	10037000
13.	B15	7.831	REINFORCEMENT, GRILLE OPG	10030837
14.	B18	7.833	DEFLECTOR, BPR FASCIA LWR	10030670
15.	B18	7.833	RETAINER, FASCIA LWR DFL-RH	10030671
16.	B15	7.831	FASCIA, FRT BPR	10042562
17.	D18	9.190	CONDENSER, A/C	3050988
18.	D19	9.242	NUT, THD BRASS/RUB (M6 X 1)	10027795
19.	N8	1.274	SEAL, RAD AIR LWR TO CNDSR-W/A C	10023641
20.	N8	1.272	BAFFLE, RAD AIR-LH	10031930
21.	N8	1.270	PANEL, RAD LWR MT	10041205
22.	N7	1.219	RADIATOR ASM (CODES MB. MXH(*1)	3057621
23.	N8	1.270	INSULATOR, RAD MT LWR	10021371
24.	N8	1.274	SEAL, RAD AIR LWR TO RAD LWR PNL	10023647
25.	N8	1.272	BAFFLE, RAD AIR RH	10031928
26.	N7	1.253	CAP, RAD FIL	10036879
27.	N8	1.270	INSULATOR, RAD MT UPR	10021538
28.	N8	1.270	PANEL, RAD UPR MT	10055019
29.	N7	1.240	RESERVIOR, COL RCVY	10036923
30.	N7	1.240	CAP, CLNT RCVY RESVR	15630112
31.	N8	1.274	SEAL, RAD AIR UPR	10021482
32.		8.982	HOSE, WSW (5/32")	
33.	E12	10.156	NOZZLE, WSWA	10024288
34.		8.963	TEE, CONN (3/16" DIA HOSE)	
35.	E12	10.153	PUMP, WSWA	22539339
36.	E12	10.154	CONTAINER, WSWA SOLV	22039340
37.		N.S.	CAP, WSWA SOLV CONTAINER	
38.	C6	8.130	PANEL, F/FDR-RH(1984)(*2)	10077314
	C6	8.130	PANEL, F/FDR-RH (1985)(*2)	10077314
39.	D20	9.647	CABLE, RDO ANT	10031602
	D20	9.647	ANTENNA, RDO	10149422
40.	C6	8.015	BOLT, HOOD CATCH	387499
41.	C6	8.080	STRIKER, LK FRT COMPT	20484234
42.	N21	12.800	SCREEN, SHRD TOP VENT	20559921
43.	C6	8.010	WEATHERSTRIP, FRT COMPT(12 269)	20880008
44.	C6	8.015	HINGE, FRT COMPT-RH (8.015)	20584604
	C6	8.015	HINGE, FRT COMPT-LH	20594605
45.	B6	7.006	BRACE, F/END LWR STRUCTURE BDY RAIL	10032967
46.	C6	8.075	HANDLE, FRT COMPT (BLA)	20318495
47.	B17	7.832	EMBLEM, FASCIA "FIERO" (1984)	10032011
	B17	7.832	EMBLEM, FASCIA "FIERO" (1985)	10030186
48.	B17	7.832	MOLDING, FASCIA-RH	10038511
	B17	7.832	MOLDING, FASCIA-LH	10038512
49.	C7	8.147	PLATE, "INDIANAPOLIS MOTOR SPEEDWAY" (1984)	10031688
50.		N.S.	WIRE, RDO GRD(*3)	
		8.985	TERMINAL, WIRE	
51.	B15	7.831	BRACE, FASCIA	10030838
52.	B18	7.833	BRACKET, FASCIA LWR DFL	10030673
53.	E12	10.154	GROMMET, WSWA HOSE (TO FRT OF DASH)	20344290
54.	E12	10.153	VALVE, WSWA CHK	25523494
55.	N11	2.587	BRACKET, PARK LP-RH	10038891
	N11	2.587	BRACKET, PARK LP-LH	10038892
56.	N20	11.950	SWITCH, COMPT LID AJAR	20545277
57.	C6	8.083	SPRING, HOOD POP-UP	20472201
58.	N21	12.242	CABLE, CONN F/COMPT LID LK	20351013
59.	N23	12.934	PANEL, RKR CVR PNL TO FDR OTR PNL-RH (1984 Y88)	20479376

59.	N23	12.934	PANEL, RKR CVR PNL TO FDR OTR PNL-LH (1984 Y88)	20479377
	C6	8.131	PANEL, RKR CVR PNL TO F/FDR OTR PNL-RH (1985 WU2)	10074288
	C6	8.131	PANEL, RKR CVR PNL TO F/FDR OTR PNL-LH (1985 WU2)	10074289
60.	C6	8.024	BUMPER, FRT COMPT (12 212)	20227543
61.	N11	2.810	HORN, "A" NOTE	10024319
62.	N11	2.810	HORN, "F" NOTE	10024318
63.	N11	2.770	PANEL, HDLP CVR-9H	20302392
	N11	2.770	PANEL, HDLP CVR-LH	20302393

NOTE 1 SEE PARTS CATALOG FOR ADDITIONAL PART NUMBERS

NOTE 2 PAINT AS REQUIRED.

NOTE 3 MAKE FROM BULK WIRE

2P08-010
081087

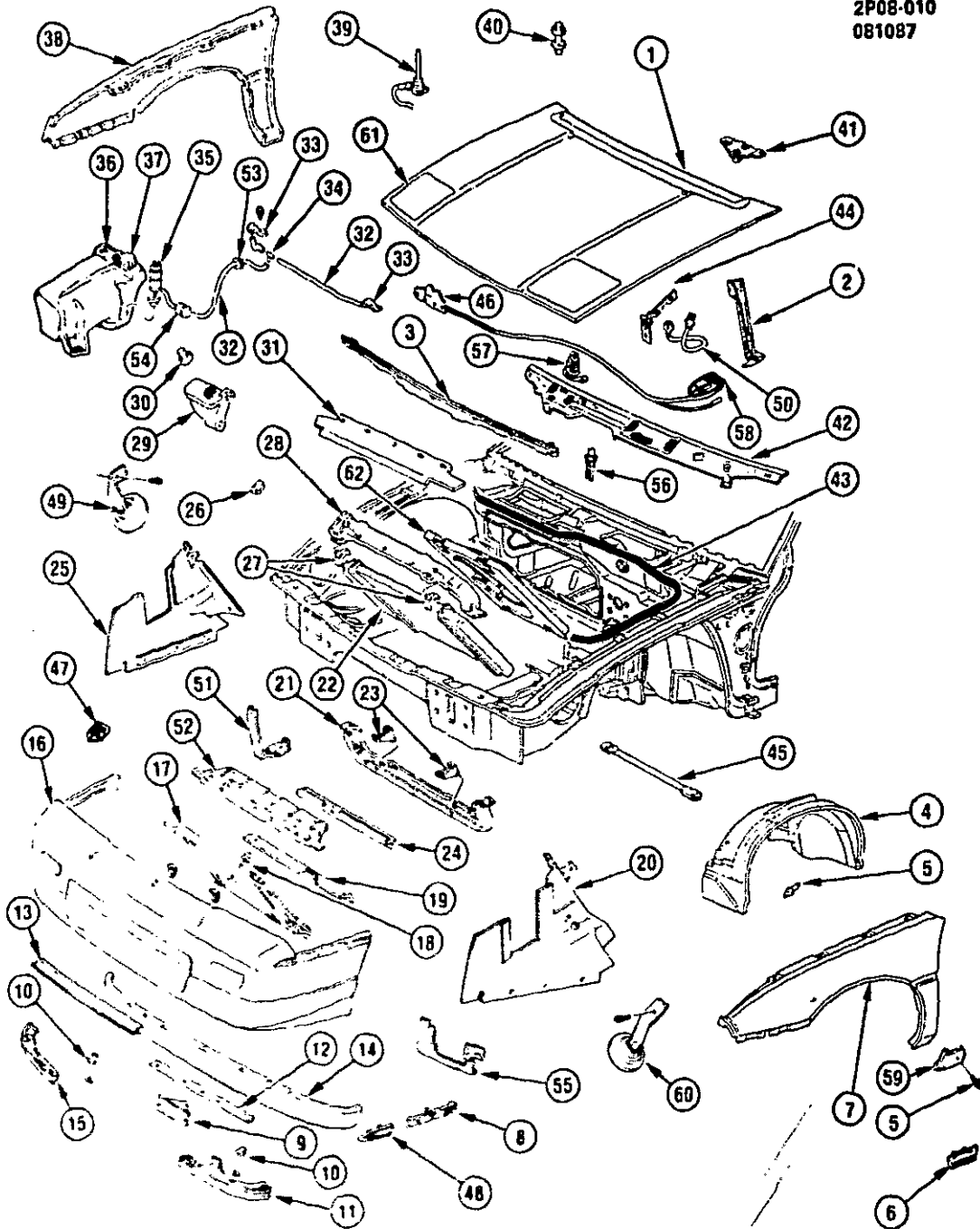

**1986-1988 PG97 SHEET METAL/FRONT END
1986-1988 PM37 SHEET METAL/FRONT END (W69)**

1.	C6	8.000	HOOD	20816584
2.	C6	8.015	SUPPORT, FRT COMPT L/D	20379366
3.	B15	7.831	REINFORCEMENT, FRT BPR FAC5IA	10041675
4.	C7	8.153	LINER, WHL HSE LNR FRT-RH	10077494
	C7	8.153	LINER, WHL HSE LNR FRT-LH	10077495
	C7	8.153	PANEL, FRT WHL HSE-RH (1988)	20835044
	C6	8.130	PANEL, FRT WHL HSE-LH (1988)	20572975
5.	N23	12.934	RETAINER, WHL HOUSE INR PNL TO FRAME (1 2 /6)	20864092
6.	C7	8.132	MOLDING KIT, FDR RR OF WHL OPG-RH (BLA)(1988)	12327901
	C7	8.132	MOLDING KIT, FDR RR OF WHL OPG-LH (BLA)	12327902
	C7	8.132	MOLDING KIT, FDR RR OF WHL OPG-RH (BLA)(1987-88)	12327901
7.	C6	8.130	PANEL, F/FDR-LH(*2)	20572975
	C7	8.133	RIVET, FDR TO BODY SI FRAME (12 934)	20375100
8.	N11	2.575	LAMP, FRT SI MKR-RH (P37 W/W69)(*4)	920058
	N11	2.575	LAMP, FRT SI MKR-LH (P37 W/W69)(*4)	920057
9.	N11	2.585	LAMP, PK AND T/SIG-RH	917328
	N11	2.585	LAMP, PK AND T/SIG-LH	917327
	N11	2.575	SOCKET, SI MKR LP	12083460
10.	B18	7.833	BRACKET, F/END PNL DFL	10021934
11.	B18	7.833	RETAINER, F/END PNL DFL-LH	10030672
12.	B15	7.831	REINFORCEMENT, FASCIA LWR DFL	10037000
13.	B15	7.831	REINFORCEMENT, GRILLE OPG	10030837
14.	B18	7.833	DEFLECTOR, FASCIA LWR	10030670
15.	B18	7.833	RETAINER, FASCIA LWR DFL-RH	10030671
16.	B15	7.831	FASCIA, FRT BPR (P37 W/W69)(* 1.2)	10042562
17.	D18	9.190	CONDENSER, A/C	3050988
18.	D19	9.242	NUT, THD BRASS/RUB (M6X1)	10027795
19.	N8	1.274	SEAL, RAD AIR LWR TO CNDSR (W/C60)	10023641
20.	N8	1.272	BAFFLE, RAD AIR-LH	10031930
21.	N8	1.270	PANEL, RAD MT LWR (1987)	10041205
	N8	1.270	PANEL, RAD MT LWR (1988)	10869177
22.	N7	1.219	RADIATOR ASM (CODES MB.MX)(* 1)	3057621
23.	N8	1.270	INSULATOR, RAD MT LWR	10021371
24.	N8	1.274	SEAL, RAD AIR LWR TO RAD LWR PNL	10023647
25.	N8	1.272	BAFFLE, RAD AIR-RH	10031928
26.	N7	1.203	CAP, RAD FIL	10038879
27.	N8	1.270	INSULATOR, RAD MT UPR	10021636
28.	N8	1.270	PANEL, RAD UPR MT	10055019
29.	N7	1.240	RESERVIOR, CLNT RCVY	10038923
30.	N7	1.240	CAP, CLNT RCVY RESVH	15630112
31.	N8	1.274	SEAL, RAD AIR UPR	10021482
32.		8.962	HOSE, WSWA (5/32)	
33.	E12	10.156	NOZZLE, WSWA	10024268
34.		8.963	TEE, CONN (3/16 DIA HOSE)	
35.	E12	10.153	PUMP, WSWA	22039339
36.	E12	10.154	CONTAINER, WSWA SOLV	22062599
37.	E12	10.151	CAP, WSWA SOLV CONTAINER	22062600
38.	C6	8.130	PANEL, F/FDR-RH (1986-87)(*2)	10077314
	C6	8.130	PANEL, F/FDR-RH (1988)(*2)	10077314
39.	D20	9.847	CABLE, RDO ANT	10031602
	D20	9.847	ANTENNA, RDO	10149422
40.	C6	8.016	BOLT, HOOD CATCH	20816588
41.	C6	8.080	STRIKER, LK FRT COMPT	20484234
42.	N21	12.800	SCREEN, SHRD TOP VENT	10074271
43.	C6	8.010	WEATHERSTRIP, FRT COMPT (12 269)	20880008
44.	C6	8.015	HINGE, FRT COMPT-RH	20594804
	C6	8.015	HINGE, FRT COMPT-LH	20594805
45.	B6	7.008	BRACE, F/END LWR STRUCTURE BDY RAIL	10032967
46.	C6	8.075	HANDLE, FRT COMPT (BLA)	20318498
47.	B17	7.832	EMBLEM, FASCIA "FIERO" (P37 W/W69)	10040813
	B17	7.832	EMBLEM, FASCIA "GT" (P97)	10036681
48.	B17	7.832	MOLDING, FASCIA-RH (P37 W/W69)	10038511
	B17	7.832	MOLDING, FASCIA-LH (P37 W/W69)	10038512
	B17	7.832	MOLDING, FASCIA-RH (P97)	10035764
	B17	7.832	MOLDING, FASCIA-LH (P97)	10035765
		8.921	NUT, MET STAMPED (5MMID)	11501793
49.	N11	2.810	HORN, "F" NOTE	10024318
50.		N.S.	WIRE, RDO GRD(*3)	
		8.985	TERMINAL, WIRE	
51.	B15	7.831	BRACE, FASCIA	10030836
52.	B18	7.833	BRACKET, FASCIA LWR DFL	10030673
53.	E12	10.154	GROMMET, WSWA HOSE (TO FRT OF DASH)	20344290

54.	E12	10.153	VALVE, WSWA CHK	25523494
55.	N11	2.587	BRACKET, PARK LP RH	10036891
	N11	2.587	BRACKET, PARK LP-LH	10036892
56.	C6	6.077	SWITCH, COMPT LID AJAR (11 950)	20545277
57.	C6	6.083	SPRING, HOOD POP UP	20472201
58.	N21	12.242	CABLE, CONN F/COMPT LID LK	20351013
59.	C6	8.130	PANEL, F/FDR LWR RR-RH (P37 W/W69)	10074288
	C6	8.130	PANEL, F/FDR LWR RR-LH	10074289
60.	N11	2.810	HORN, "A" NOTE (1986-87)	10024319
	N11	2.810	HORN, "A" NOTE (1988)	1892164
61.	N11	2.770	PANEL, HDLP CVR-RH	20302392
	N11	2.770	PANEL, HDLP CVR-LH	20302393
62.	N6	1.055	FAN, COOL(*4)	

NOTE 1 SEE PARTS CATALOG FOR ADDITIONAL PART NUMBERS

NOTE 2 PAINT AS REQUIRED

NOTE 3 MAKE FROM BULK WIRE

NOTE 4 SEE RESPECTIVE GROUP FOR DETAILED ILLUSTRATED VIEW

2P08-012
081187

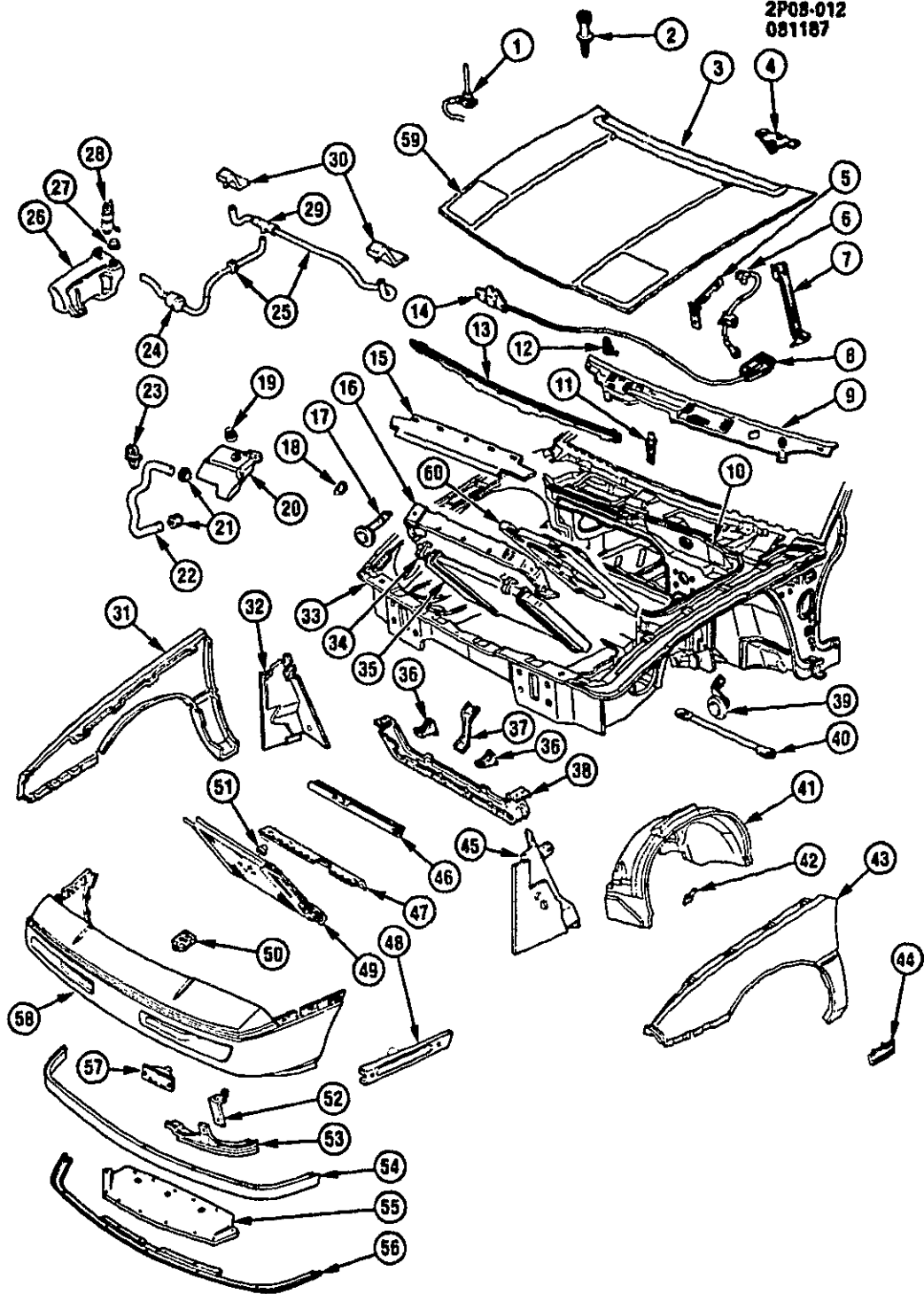

2P08-012

1987-1988 P37 SHEET METAL/FRONT END

1.	D20	9.647	CABLE, ANT	10031602
2.	C6	8.015	BOLT, HOOD CTH	20616568
3.	C6	8.000	HOOD	20816564
4.	C6	8.080	STRIKER, LK FRT COMPT	20484234
5.	C6	8.015	HINGE, FRT COMPT-RH	20594604
	C6	8.015	HINGE, FRT COMPT-LH	20594605
6.		N.S.	WIRE, GRD	
7.	C6	8.015	SUPPORT, FRT COMPT LID	20379366
8.	C6	8.076	HANDLE, FRT COMPT (BLA)	20316498
9.	N21	12.800	SCREEN, SHRD TOP VENT	10074271
10.	C6	8.010	WEATHERSTRIP, FRT COMPT (12 269)	20580008
11.	N21	12.243	SWITCH, FRT & RR COMP LID AJAR (11 950)	20545277
12.	C6	8.083	SPRING, HOOD POP-UP	20472201
13.	B15	7.831	REINFORCEMENT, FRT BPR FASCIA	10041876
14.	C6	8.080	LOCK, FRT COMPT LID & ACTR-W/CBL	20369893
15.	N8	1.274	SEAL, RAD AIR UPR	10021482
16.	N8	1.270	PANEL, RAD MT UPR	10056019
17.	N11	2.810	HORN, "F" NOTE (1987)	10024318
18.	N7	1.203	CAP, RAD FIL	10036879
19.	N7	1.240	CAP, CLNT RCVY RESVR	15630112
20.	N7	1.240	RESERVOIR, CLNT RCVY	10036923
21.		8.948	CLAMP, WORM GEAR HEX SLOT SCREW (250 X 625) SS	25518880
22.		N.S.	HOSE, CLNT RCVY	
23.		N.S.	CLIP, HOSE	
24.	E12	10.153	VALVE, WSWA CHK	25523494
25.		8.962	HOSE, WSWA (5/32X25)(*1)	1359744
		8.963	TEE, CONN (3/16 DIA HOSE)	6272766
26.	E12	10.154	CONTAINER, WSWA SOLV	22062599
27.	E12	10.151	CAP, WSWA SOLV RESV	22082600
28.	E12	10.153	PUMP, WSWA	22039339
29.		8.983	TEE, CONN (3/16 DIA HOSE)	6272766
30.	E12	10.158	NOZZLE, WSWA	10024268
31.	C6	8.130	PANEL, F/FDR-RH (1987)(*2)	10077314
	C6	8.130	PANEL, F/FDR-RH (1988)(*2)	10077314
32.	N8	1.272	BAFFLE, RAD AIR-RH (P37)	10040041
33.		N.S.	COMPARTMENT, FRT(*3)	
34.	N8	1.270	INSULATOR, RAD MT UPR	10021536
35.	N7	1.219	RADIATOR, (CODES MB.MX.MC MY)(*4)	3057621
	N7	1.219	RADIATOR, (CODES M2.M3)(*4)	3057621
36.	N8	1.270	INSULATOR, RAD MT LWR	10021371
37.	N7	1.263	BRACE, F/END PNL DEFL (P37 EXC W69)	10040084
38.	N8	1.270	PANEL, RAD MT LWR (1987)	10041205
	N8	1.270	PANEL, RAD MT LWR (1988)	10069177
39.	N11	2.810	HORN, "A" NOTE (1987)	10024319
	N11	2.810	HORN, "A" NOTE (1988)	1892164
40.	B6	7.008	BRACE, F/END LWR STRUCTURE BODY RAIL (15-87)	10032987
41.	C7	8.153	PANEL, WHL HSE LNR FRT-RH	10077494
	C7	8.153	PANEL, WHL HSE LNR FRT-LH	10077495
	C7	8.153	PANEL, FRT WHL HSE-RH (1988)	20835044
	C7	8.153	PANEL, FRT WHL HSE-LH (1988)	20835045
42.		8.977	SCREW, HEX TAP W/WA (M4 2X1 41X16) POR	10021798
43.	C6	8.130	PANEL, F/FDR-LH(*2)	20572976
44.	C7	8.132	MOLDING KIT, FDR RR OF W/OPG-RH (BLA)(W/B97)	12327901
	C7	8.132	MOLDING KIT, FDR RR OF W/OPG-LH (BLA)(W/B97)	12327902
45.	N8	1.272	BAFFLE, RAD AIR-LH (P37 EXC A/C)	10040042
46.	N8	1.274	SEAL, RAD AIR LWR TO RAD LWR PNL	10023847
47.	N8	1.274	SEAL, RAD AIR LWR TO CNDSR-W/A C	10023841
48.	N11	2.575	LAMP, FRT SI MKR-RH (P37 EXC W69)	5974302
	N11	2.575	LAMP, FRT SI MKR-LH (P37 EXC W69)	5974301
49.	D18	9.190	CONDENSER, A/C	3050888
50.	B17	7.832	EMBLEM, F/END FASCIA "FIERO" (P37)	10040813
51.	D19	9.242	NUT, THD BRASS/RUB (M6X1)	10027795
52.	B18	7.833	BRACKET, F/END PNL DFL	10021934
53.	B18	7.833	SUPPORT, FRT BPR FASCIA-RH (P37 EXC W69)	10040044
	B18	7.833	SUPPORT, FRT BPR FASCIA-LH (P37 EXC W69)	10040045
54.	N7	1.263	DEFLECTOR, F/END PNL (P37 EXC W69)	10040061
55.	B18	7.833	FILLER, FRT BPR CTR (P37 EXC W69)	10041881
56.	N7	1.263	REINFORCEMENT, F/END PNL DEFL (P37 EXC W69)	10040062
57.	N11	2.585	LAMP, PK AND T/SIG RH	917328
	N11	2.585	LAMP, PK AND T/SIG-LH	917327
58.	B15	7.831	FASCIA, FRT BPR (P37 W/W69)(1987)	10042562
	B15	7.831	FASCIA, FRT BPR (EXC W69)	10056040
59.	N11	2.770	PANEL, HDLP CVR-RH	20302392

59. N11 2.770 PANEL, HDLP CVR LH
60. N6 1.055 FAN, COOL (*4)

20302393

NOTE 1 CUT TO SIZE FROM BULK STOCK

NOTE 2 DRILL HOLES AS REQUIRED

NOTE 3 SEE GROUP 12 000 FOR EXPLODED VIEW

NOTE 4 SEE PARTS CATALOG FOR ADDITIONAL PART NUMBERS

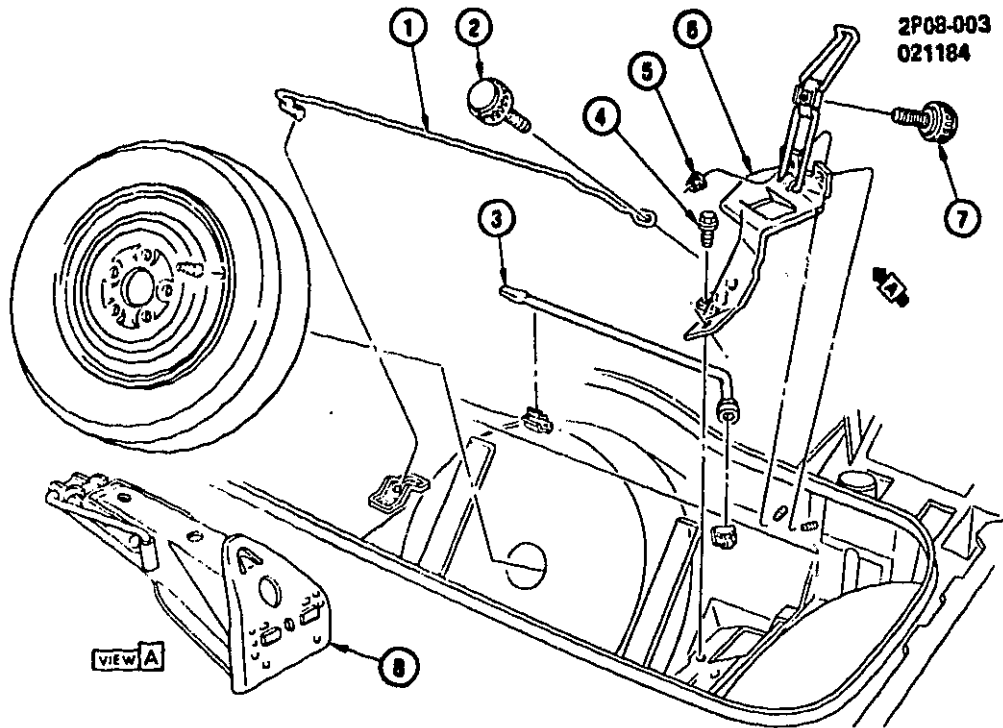

2P08-003

1984 P SPARE WHEEL STOWAGE & JACK PARTS (EXC Y82)

1.	B15	7.632	RETAINER, SPARE WHEEL STOW	10023232
2.	B15	7.632	BOLT, SPARE WHEEL STOW RETAINER	10024098
3.	C9	8.821	WRENCH, WHEEL	14038400
4.		8.900	BOLT, HEX W/FL WA & NYLON WA (M6 X 1 X 20)	
5.		8.917	NUT, HEX W/CON WA (M6 X 1)	
6.	C9	8.820	BRACKET, JACK STOW	10026218
7.	C9	8.820	BOLT, JACK STOW	10026216
8.	C9	8.820	JACK, CAR	10030932

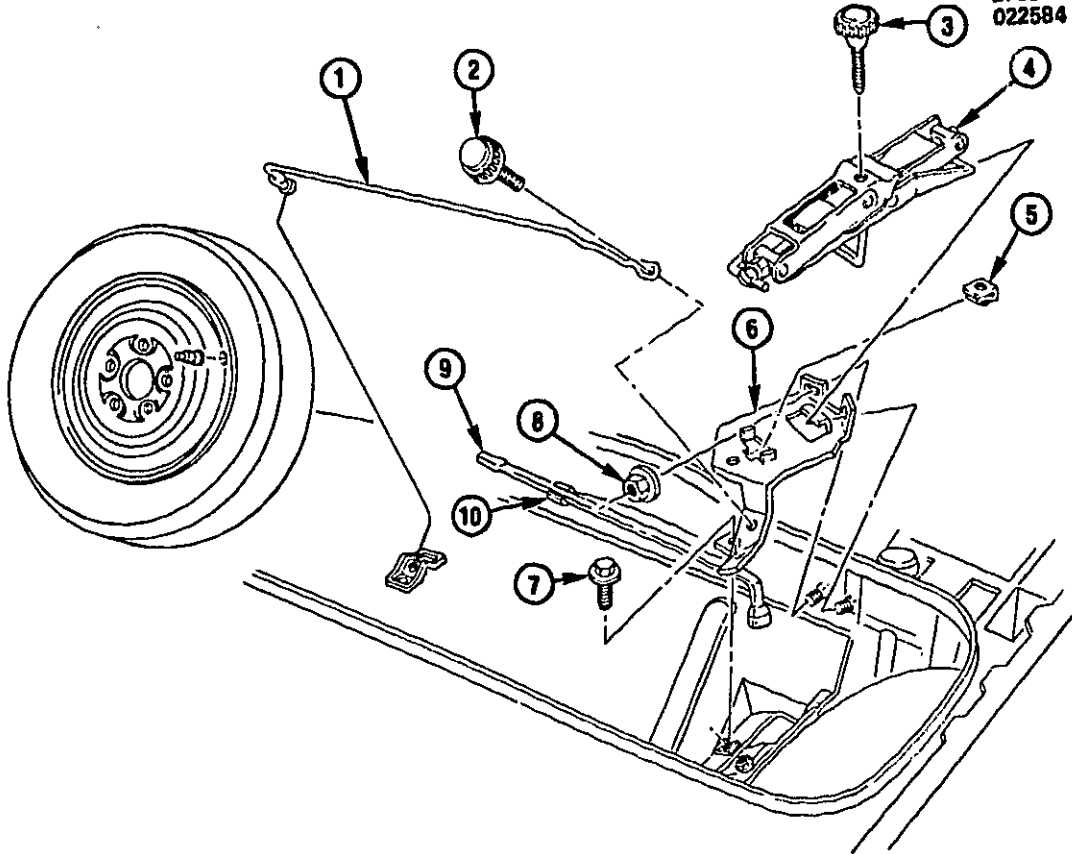

2P08-008

1984 P SPARE WHEEL STOWAGE & JACK PARTS (Y82)

1.	B15	7.632	RETAINER, SPARE WHL STOW	10023232
2.	B15	7.632	BOLT, SPARE WHL STOW RET	10024096
3.		N.S.	BOLT, JACK RET	
4.	C9	8.820	JACK, (SCISSOR TYPE)	10030932
5.		8.921	NUT, U-SHAPED (M8 X 1 25)	
6.	C9	8.820	BRACKET, JACK STOW	10041843
7.		8.900	BOLT, HWH (M6 X 1 X 20)	
8.		8.917	NUT, HWH (M6 X 1 X 5 5)	
9.	C9	8.821	WRENCH, WHL (19 58MM)	14038400
10.	C9	8.820	RETAINER, JACK HDL	20416326

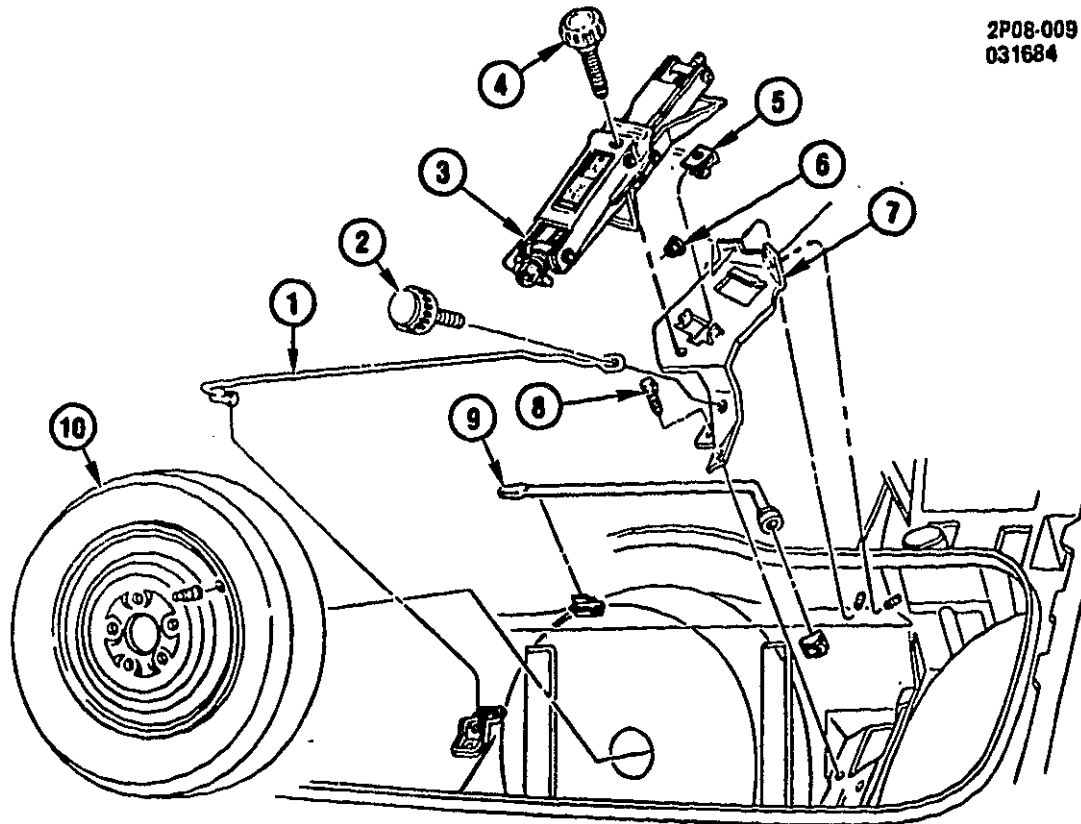

2P08-009

1985-1988 P SPARE WHEEL STOWAGE & JACK PARTS

1. B15	7.632	RETAINER, SPARE WHEEL STOW	10023232
2. B15	7.632	BOLT, SPARE WHEEL STOW RETAINER	10024096
3. C9	8.820	JACK, AUTO	10030932
4. B15	7.629	BOLT, JACK STOW	10030929
5.	8.921	NUT, U-SHAPE (M8X1 25)	12337966
6.	8.917	NUT, HEX W/CON WA (M6X1)	11508277
7. C9	8.820	BRACKET, JACK STOW	10041843
8.	8.900	SCREW, HWH (M6X1X20)	11508800
9. C9	8.821	WRENCH, WHL(19.56 MM)	14038400
10. N19	5.803	WHEEL, COMPACT SPARE (15"X4"-RK)	9590503

2P08-005
061087

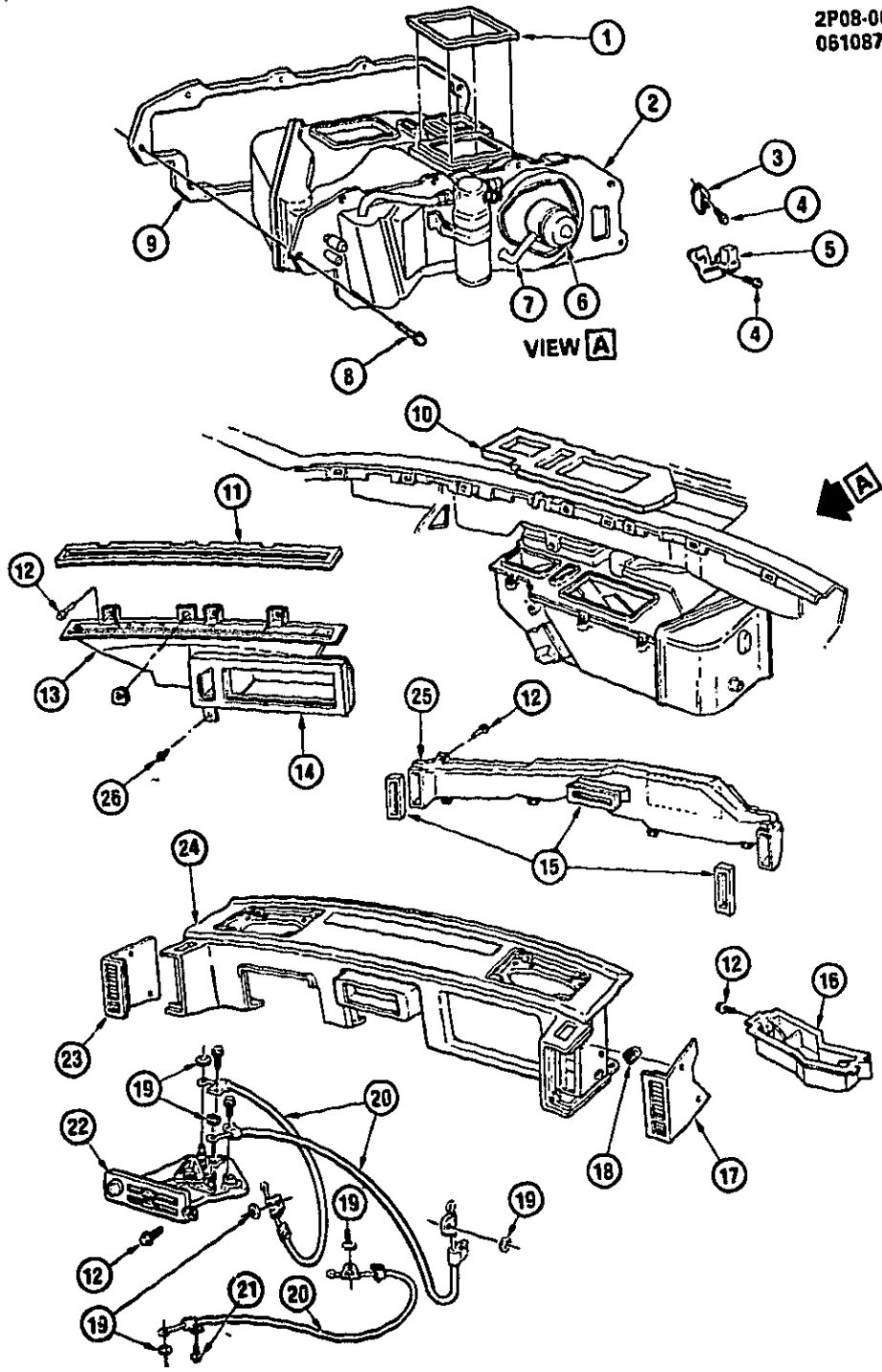

2P08-005

1984-1988 P HEATER & DEFROSTER SYSTEM (C41)

1.	D18	9.211	GASKET, HTR BLO MODULE	10033693
2.		N.S.	HEATER, SEE EXPLODED ART 2P08-004	
3.	C14	8.855	RESISTOR, BLO MTR	10024378
4.		8.977	SCREW, HWH TAP (M4.2X1.41X13)	11508258
5.	D20	9.277	RELAY, HTR HI BLO (3.140)	10026663
	C14	8.855	BRACKET, BLO MTR RELAY	10026850
6.	C14	8.855	MOTOR, BLO (9.215)	22098841
7.	C14	8.859	TUBE, MTR CLG (9.218)	3035192
8.		8.977	SCREW, HWH TAP (M6.3X1.81X35)	499558
9.	D20	9.262	GASKET, BLO MOD TO DASH	3052129
10.	E5	9.779	SEAL, INT DEFR TO MOD	10021274
11.		N.S.	SEAL, DISTR TO PNL	
12.		8.977	SCREW, HEX WA HD C/R TAP (M4.2X1.41X20) POR	11503552
13.	E5	9.779	DISTRIBUTOR, DEFR & AIR	10021286
14.	D20	9.262	SEAL, POLYURETHANE FOAM	3999511
15.	D20	9.262	SEAL, FOAM (46 1/2"X3/8"X1/2")	363139
16.	D20	9.262	OUTLET, HTR AIR	10021273
17.	E15	10.252	PLATE, I/P TR-RH (GRAPHITE GRAY)(*1)	10021232
18.		8.921	NUT, U SPR-THD SIZE 8 NYLON	
19.		8.921	NUT, SPL PUSH-ON TYPE A (M3.6X1.123)(PHOS)	11501937
20.	E6	9.787	BOWDEN WIRE REPAIR	6258384
21.		8.977	SCREW, HWH TAP (M4.2X1.41X16) PZOR	11509135
22.	C13	8.849	CONTROL, HTR (1984)	18018312
	C13	8.849	CONTROL, HTR (1985-88)	18050082
23.	E15	10.252	PLATE, I/P TR-LH (GRAPHITE GRAY)(*1)	10021233
24.	E14	10.235	PAD, I/P(*1)	10042617
25.	D20	9.262	DISTRIBUTOR, AIR DUCT	10021282
26.		8.977	SCREW, HEX WA HD C/R TAP (M4.2X1.41X20) POR	11503552

NOTE 1- PAINT TO MATCH.

2P08-004
072283

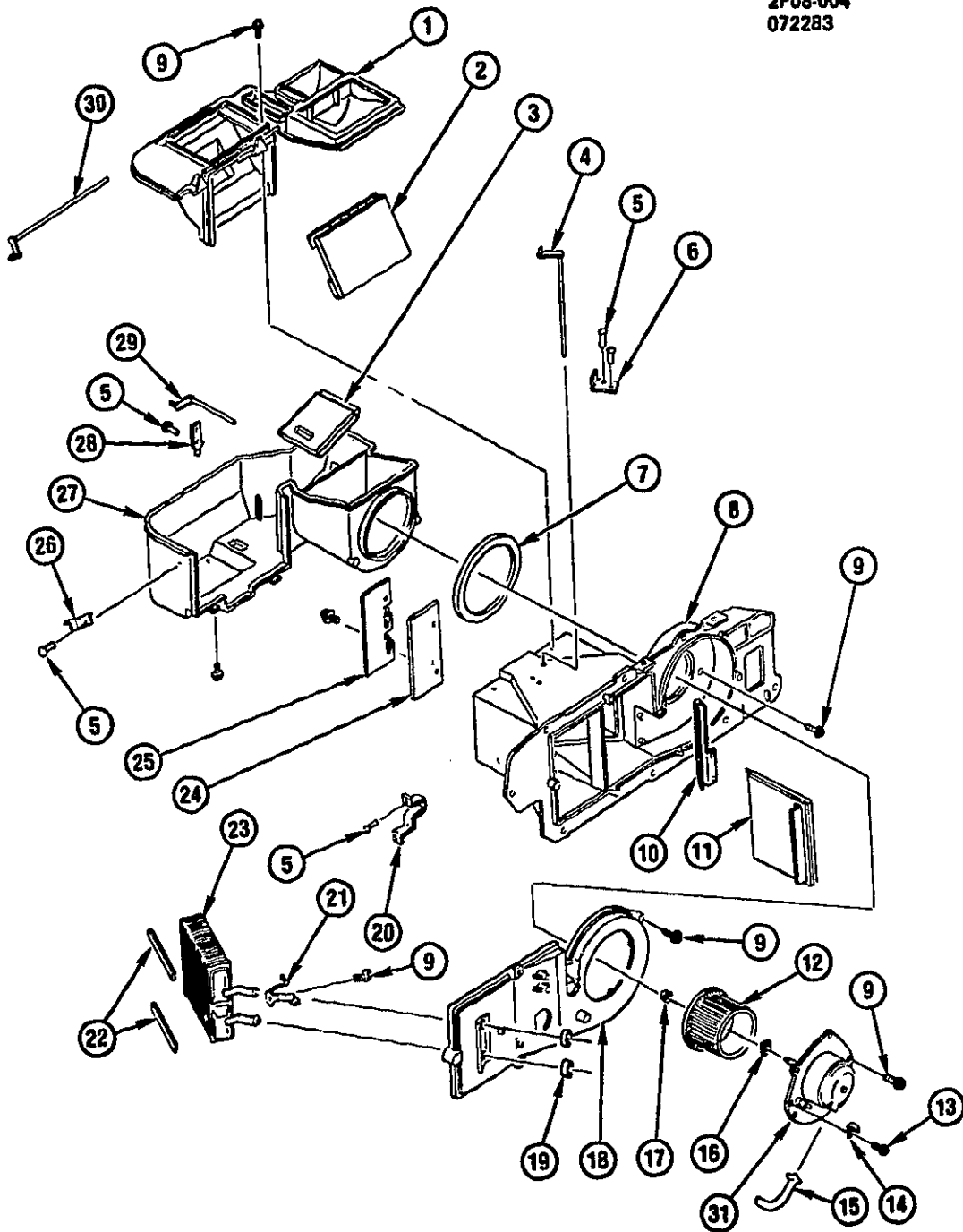

2P08-004

1984-1988 P HEATER & BLOWER ASM

1.	E5	9.786	CASE, AIR INL & DIST	3052333
2.	E5	9.786	VALVE, VENT	3052119
	E6	9.787	CABLE, VENT CONT (1984)	10021305
	E6	9.787	BOWDEN WIRE REPAIR, 13FT HSG & 60FT WIRE(*1)	6258384
3.	E5	9.779	VALVE, DEFR	3052118
4.	E5	9.786	SHAFT, TEMP VLV-W/LVR	3052112
5.	N.S.		RIVET, TRUSS HD (9/16" X 1/4")	
6.	N.S.		BRACKET, CBL MTG	
7.	C13	8.854	SEAL, HTR & BLO CASE	3052127
8.	C13	8.854	CASE, HTR-W/BFL & VLV	3052337
9.		8.977	SCREW, HWH TAP (M4 2 X 1 41 X 13)	
10.		N.S.	BAFFLE, AIR (PART OF #8)	
11.	E5	9.786	VALVE, TEMP-W/SEAL (1984-86)	3052136
	E5	9.786	VALVE, TEMP-W/SEAL (1987)	3052120
12.	C14	8.857	FAN, BLO	3094155
13.		8.977	SCREW, HWH TAP (M4.2 X 1 41 X 14)	
14.	C14	8.855	TERMINAL, BLO MTR GRD (2 530)	3033932
15.	C14	8.859	TUBE, MTR CLG (9.218)	3035192
16.	C14	8.857	SUPPORT, BLO IMP (9.216)	3015645
17.	N6	1.015	NUT, BLO FAN (8 857)	3042351
18.	C14	8.855	COVER, BLO	3052005
19.	C13	8.854	SEAL, HTR CORE TUBE	3052297
20.		N.S.	BRACKET, MT	
21.	C13	8.854	CLAMP, CORE MT	3039412
22.	C13	8.854	SEAL, HTR CORE (9.211)	3052253
23.	C13	8.854	CORE, HTR	3052181
24.	C13	8.854	SEAL, HTR CORE CASE	3052389
25.	C13	8.854	CLIP, HTR CORE MT	3052108
26.	E6	9.787	BRACKET, CBL MT (1984)	10031217
27.	E5	9.786	CASE, AIR INL & DISTR	3052333
28.		N.S.	BRACKET, CBL MT	
29.	E5	9.779	SHAFT, DEFR VLV-W/LVR	3052114
30.	E5	9.786	SHAFT, VENT VLV-W/LVR	3052113
31.	D19	9.216	MOTOR, BLO	22098841

NOTE 1: MAKE CABLE ASM FROM CABLE REPAIR KIT

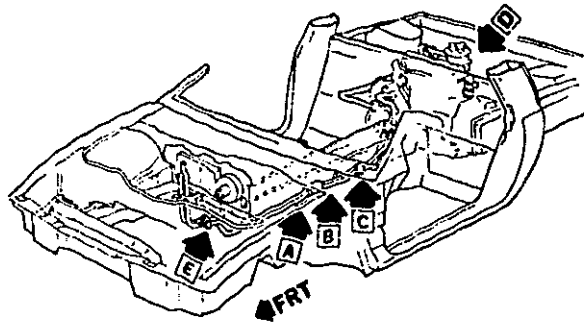

2P08-006
020384

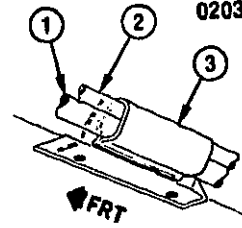

VIEW A

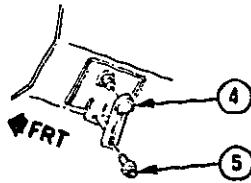

VIEW B

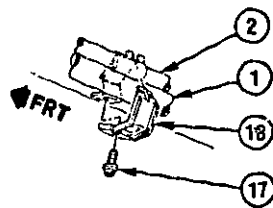

VIEW C

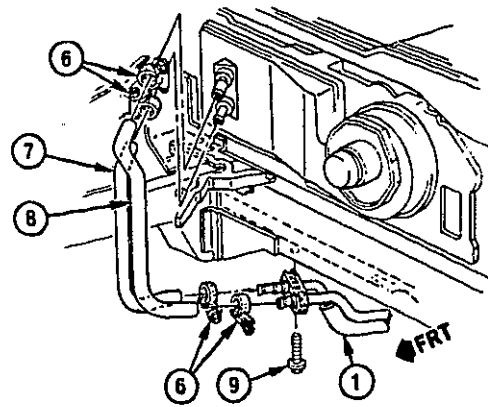

VIEW E

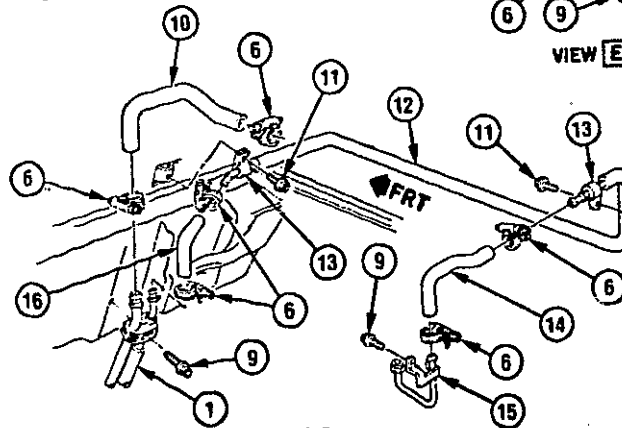

VIEW D

1984-1986 P HOSES & PIPES/HEATER

1.	C13	8.846	PIPE, UNDERBODY HTR INL	10038186
2.	C13	8.846	PIPE, UNDERBODY HTR OTLT	10038765
3.		N.S.	INSULATION	
4.	C13	8.846	SHIELD, HTR INL & OTLT PIPE (1984)	10026098
	C13	8.846	SHIELD, HTR INL & OTLT PIPE (1985-86)	10041707
5.		8.900	BOLT, HEX (M5 X 8 X 8)(1984)	
6.		8.948	CLAMP, GEAR TYPE (5/8" TO 1 1/4")	
7.	C13	8.846	HOSE, HTR INL	10021319
8.	C13	8.846	HOSE, HTR OTLT	10021320
9.		N.S.	SCREW	
10.	C13	8.846	HOSE, HTR OTLT TO WATER PUMP	10038292
11.		8.977	SCREW, HWH TAP (1/4" - 14 X 3/4")	
12.	C13	8.846	PIPE, HTR INL	10024471
13.		8.950	CLIP, OPEN LOOP (44 - RUBBER COAT)	
14.	C13	8.846	HOSE, HTR INL	10021318
15.	C13	8.846	PIPE, HTR INL TO MANIFOLD	10024159
16.	C13	8.846	HOSE, HTR INL	10038502
17.		8.977	SCREW, HWH TAP (M6.3 X 1 B1 X 16)	
18.	C13	8.846	CLAMP, HTR INL & OTLT PIPE	10031273

1984-1988 P A/C & HEATER MODULE ASM

1.	E5	9.779	VALVE, DEFR	3052170
2.		N.S.	BAFFLE, AIR (PART OF #3)(1984-85)	
	E5	9.784	BAFFLE, AIR (1986-88)	3053801
3.	E5	9.779	CASE, DEFR VLV-W/BAFFLE	3054030
4.		N.S.	SEAL, CASE	
5.	E5	9.782	VALVE, W/FITTING	3052167
6.		8.921	NUT, SPL PUSH-ON TYPE A (M3 6X11 23)(PHOS)	11501937
7.		N.S.	SEAL, OPG LINK	
8.	E5	9.779	LINK, DEFR VLV ADJ-W/SPR	3052417
9.	E5	9.786	COVER, DISTR & AIR INL CASE (1984-85)	3052130
	E5	9.786	COVER, CASE DISTRIBUTOR (1986-88)	3092922
10.	E5	9.786	SEAL, MODE VLV	303139
11.	E5	9.786	VALVE, MODE	3052386
	E5	9.786	PIN, MODE VLV LINK	3037080
	E5	9.786	SEAL, MODE VLV	3052162
12.	E5	9.786	SPRING, MODE VLV RET	3052314
13.	E5	9.786	LINK, MODE VLV ADJ-W/SPR	3052418
14.	E5	9.786	RETAINER, LINK	1484109
15.	D19	9.215	CASE, BLOWER	3052131
	D20	9.262	GASKET, BLO MOD TO DASH	3052129
		8.977	SCREW, HWH (M4 2X) 41X13) POR HILO	11508256
16.	E5	9.786	VALVE, TEMP	3052135
17.		N.S.	BAFFLE, AIR (PART OF #46)	
18.	C14	8.857	NUT, BLO FAN	3042315
19.	C14	8.857	FAN,BLO	3094155
20.	D19	9.216	WASHER, FAN SUPT	3015645
21.	D19	9.215	MOTOR, BLOWER	22098841
22.	C14	8.856	TERMINAL, BLO MTR GRD (2 530)	3033932
23.	D19	9.218	TUBE, MOTOR COOLING	3035192
24.	D20	9.275	SWITCH, PRESS CYCLING CUTOFF	3041596
25.		N.S.	GASKET, O-RING (PART OF 24)	
26.	D18	9.195	ACCUMULATOR, EVAP (1984)	2724312
	D18	9.195	ACCUMULATOR, DEHYDR (1985-88)	3059313
27.	D18	9.195	BRACKET, ACCUM (1984)	3052627
	D18	9.196	BRACKET, SUPT ACCUM (1985-88)	3057638
28.	D18	9.196	CLAMP, ACCUM TO MTG BRKT	3054104
29.		8.950	CLAMP, CLOSED LOOP (M22 2)	
30.	D19	9.213	ORIFICE, W GSKT (1984-85)	3033879
31.		8.927	O-RING, NEOPRENE (RED)(3/4" FITTINGS-CAPTURED)	3093411
32.	D18	9.211	SEAL, EVAP CORE	3052159
33.	D18	9.210	CORE, EVAP (1984)	3054185
	D18	9.210	CORE, EVAP (1985-88)	3090045
34.	D18	9.210	FILTER, EVAP WATER	3090870
35.	C13	8.854	COVER, HTR CORE-W/BRKT	3090992
	C13	8.854	GASKET, HTR CORE CVR TO CASE	3056495
36.	C13	8.854	CLIP, HTR CORE MTG	3053735
37.		8.950	CLIP, CLOSED LOOP TUBE 7/8" HOLE 13/32"	2041644
		8.977	SCREW, HWH TAP (M4 2X1 41X16)	11509374
38.		8.948	CLAMP, DRAIN TUBE (31 TO 75 DIA 2C CHR)	477402
39.		N.S.	TUBE, EVAP CASE DRAIN	
40.	D18	9.211	DRAIN, EVAP CASE SUMP	3053704
	D18	9.211	GASKET, SUMP DRAIN TO EVAP CASE	3056496
41.	C13	8.854	SEAL, HTR CORE (9 211)	3052253
42.	C13	8.854	SEAL, HTR CORE TUBE	3052160
43.	C13	8.854	CORE, HEATER	3052427
44.	C13	8.854	STRAP, HTR COREMTG	3052411
45.	E6	9.787	BRACKET, TEMP VLV CBL MTG	3052316
46.	C13	8.854	CASE, HTR CORE-W-BFL	3053981
47.	E5	9.786	LEVER, TEMP VLV CONT	3052165
48.	E5	9.786	RETAINER, LINK	1484109
49.	E8	9.789	ACTUATOR, AIR INL (ELECT)	3052050
50.	E5	9.786	LINK, AIR INL VLV ADJ W SPR	3052416
51.	E6	9.789	ACTUATOR, MODE (ELECT)	3052051
52.	E5	9.779	SHAFT, DEFR VLV-W-LVR	3052166

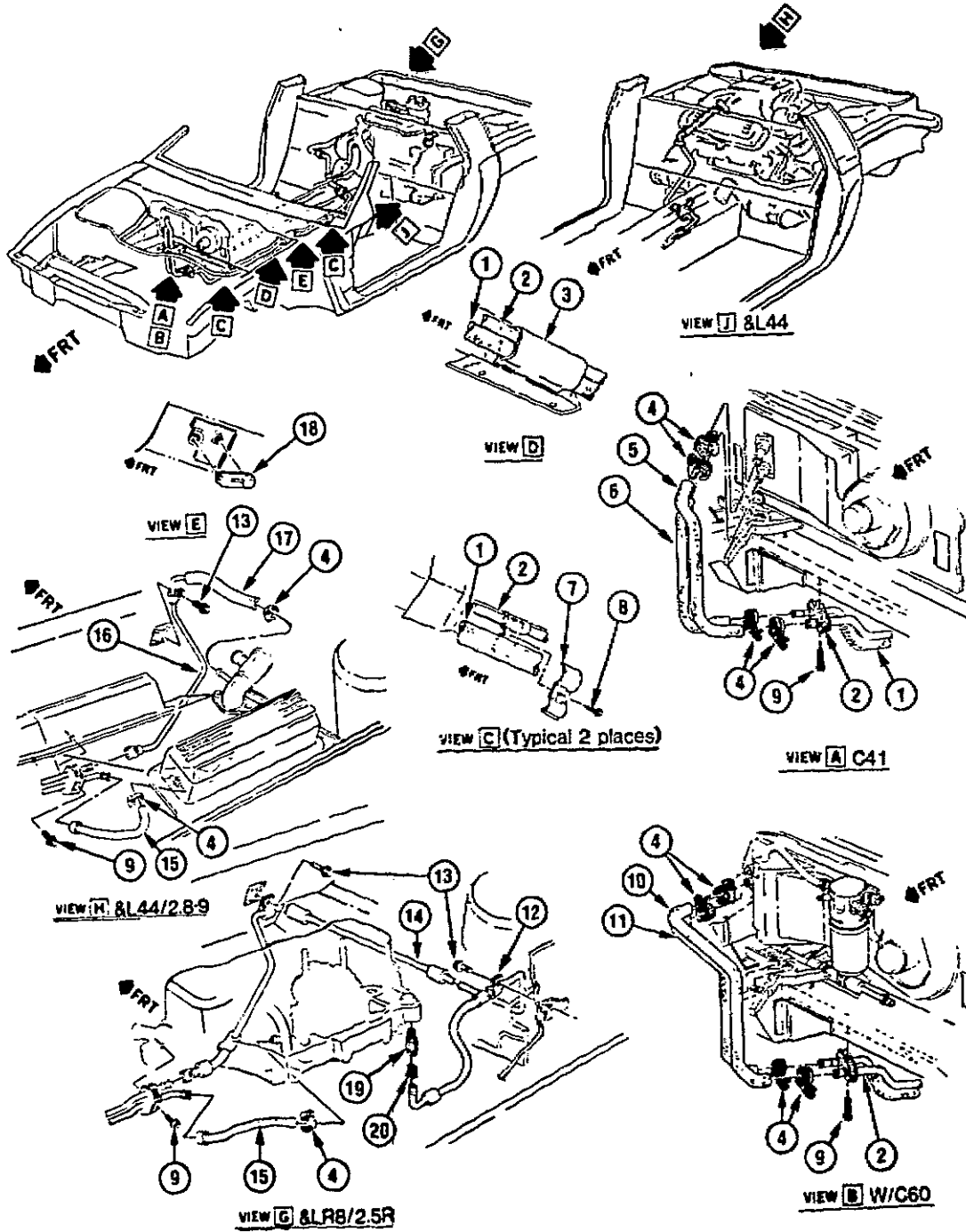

1987-1988 P HOSES & PIPES/HEATER

1.	C13	8.846	PIPE, HTR INL (UNDERBODY)(1987)	10042680
	C13	8.846	PIPE, HTR INL (UNDERBODY)(1988)	10077285
2.	C13	8.846	PIPE, HTR OTLT (UNDERBODY)(1987)	10042682
	C13	8.846	PIPE, HTR OTLT (UNDERBODY)(1988)	10077290
3.		N.S.	INSULATOR, PIPE	
4.		8.946	CLAMP, WORM GEAR (62 TO 1 25)	12337891
5.	C13	8.846	HOSE, HTR OTLT-W/C41 (1987)	14101516
	C13	8.846	HOSE, HTR OTLT-W/C41 (1988)	10089157
6.	C13	8.846	HOSE, HTR INL-W/C41 (1987)	14101514
	C13	8.846	HOSE, HTR INL-W/C41 (1988)	10089155
7.		N.S.	CLIP, PIPE	
8.		8.977	SCREW, HEX WA HD C/R TAP (M4 2X1 41X20) POR	22536997
9.		8.977	SCREW, HWH TAP	
10.	C13	8.846	HOSE, HTR OTLT-W/C60 (1987)	14101517
	C13	8.846	HOSE, HTR OTLT-W/C60 (1988)	10089158
11.	C13	8.846	HOSE, HTR INL-W/C60 (1987)	14101515
	C13	8.846	HOSE, HTR INL-W/C60 (1988)	10089156
12.		8.950	CLIP, OPEN LOOP (44 DIA) RUBBER COAT	3866187
13.		8.977	BOLT, HWH TAP (M6 3X1 81X20)PZOR	12337828
14.	C13	8.846	PIPE, HTR INL (ENG COMPT)(1987)	10042685
	C13	8.846	PIPE, HTR INL (ENG COMPT)(1988)	10080288
	C13	8.846	CONNECTOR, HTR INL (2 5R)	10042691
		8.982	HOSE (5/8 IDX25 FT)(GM6140)HEATER	12322342
	C13	8.846	RETAINER, HTR INL PIPE (2 5R)(1987)	10089612
15.	C13	8.846	HOSE, HTR INL TO INTAKE MANIFOLD	10042688
16.	C13	8.846	PIPE, HTR INL	10080267
17.	C13	8.846	HOSE, HTR INL TO ENG	10042694
18.	C13	8.846	SHIELD, HTR INL & OTLT PIPE (9 220)	10041707
19.	C14	8.866	CONTROL, HTR WTR HOSE W/RETAINER & O RING	10042695
20.	C13	8.846	RETAINER, HEATER PIPE	10089613

2P08-015
030987

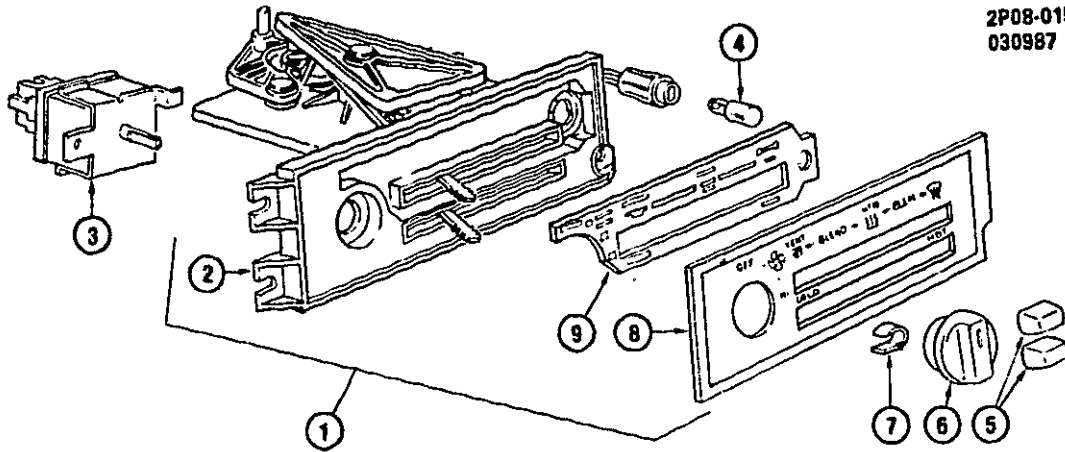

2P08-015

1985-1988 P HEATER CONTROL ASM

1.	C13	8.849	CONTROL, HTR	16050062
2.		N.S.	HOUSING(* 1)	
3.	C13	8.852	SWITCH, FAN (9 275)	16023827
4.	D20	9.279	LAMP, CONT DIAL	7895189
5.	C13	8.852	KNOB, TEMP (9 278)	16048678
6.	C13	8.852	KNOB, BLOWER (9 275)	16039103
7.	C13	8.852	SPRING, BLO KNOB (9 275)	16014896
8.		N.S.	APPLIQUE(* 1)	
9.		N.S.	LIGHTPIPE(* 1)	

NOTE 1 PART OF DIAL PACKAGE PART NUMBER 1227721

PONTIAC CHASSIS GROUP 9.000

ILLUSTRATION INDEX

TITLE	GRID
1984-1988 P A/C & HEATER MODULE ASM	J5
1984-1988 P A/C COMPRESSOR ASM DA-6/HR-6	J6
1986-1988 P A/C COMPRESSOR ASM/V-5	J8
1984-1985 P A/C COMPRESSOR MOUNTING-2.5L L4 (LR8 W/W72)	J9
1985-1988 P A/C COMPRESSOR MOUNTING-2.6L V6 (L44/2.8-9)	J10
1986 P A/C COMPRESSOR MOUNTING-2.5L L4 (LR8/2.5R)	J11
1987-1988 P A/C COMPRESSOR MOUNTING-2.5L L4 (LR8/2.5R)	J12
1984 P A/C REFRIGERATION SYSTEM	J14
1985-1987 P A/C REFRIGERATION SYSTEM	J16
1988 P A/C REFRIGERATION SYSTEM	J18
1984-1988 P A/C AIR DISTRIBUTION SYSTEM	J20
1985-1988 P A/C & HEATER CONTROL ASM (C60)	J21
1984-1988 P ANTENNA ASM/FIXED MAST	J22
1988 P CLUSTER ASM/INSTRUMENT PANEL	J23

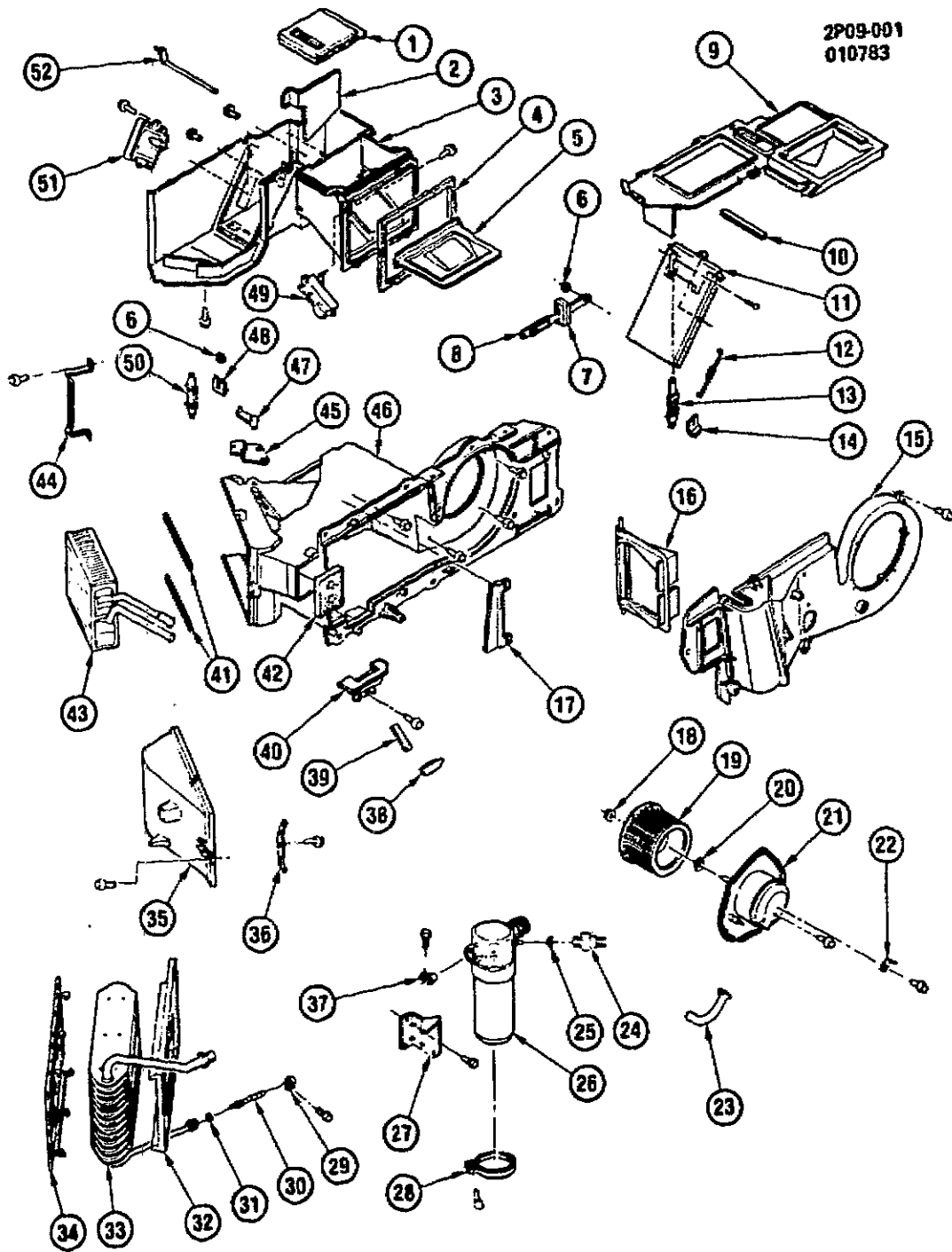

2P09-001
010783

2P09-001

1984-1988 P A/C & HEATER MODULE ASM

1.	E5	9.779	VALVE, DEFR	3052170
2.		N.S.	BAFFLE, AIR (PART OF #3X1984 85)	
	E5	9.784	BAFFLE, AIR (1986-88)	3053801
3.	E5	9.779	CASE, DEFR VLV-W/BAFFLE	3054030
4.		N.S.	SEAL, CASE	
5.	E5	9.782	VALVE, W/FITTING	3052167
6.		8.921	NUT, SPL PUSH-ON TYPE A (M3 6X11 23KPHOS)	11501937
7.		N.S.	SEAL, OPG LINK	
8.	E5	9.779	LINK, DEFR VLV ADJ-W/SPR	3052417
9.	E5	9.786	COVER, DISTR & AIR INL CASE (1984-85)	3052130
	E5	9.786	COVER, CASE DISTRIBUTOR (1986-88)	3082922
10.	E5	9.786	SEAL, MODE VLV	383139
11.	E5	9.786	VALVE, MODE	3052386
	E5	9.786	PIN, MODE VLV LINK	3037080
	E5	9.786	SEAL, MODE VLV	3052162
12.	E5	9.786	SPRING, MODE VLV RET	3052314
13.	E5	9.786	LINK, MODE VLV ADJ-W/SPR	3052418
14.	E5	9.786	RETAINER, LINK	1484109
15.	D19	9.215	CASE, BLOWER	3052131
	D20	9.262	GASKET, BLO MOD TO DASH	3052129
		8.977	SCREW, HWH (M4 2X1 41X13) POR HILO	11508256
16.	E5	9.786	VALVE, TEMP	3052135
17.		N.S.	BAFFLE, AIR (PART OF #46)	
18.	C14	8.857	NUT, BLO FAN	3042315
19.	C14	8.857	FAN, BLO	3094155
20.	D19	9.216	WASHER, FAN SUPT	3015545
21.	D19	9.215	MOTOR, BLOWER	22098841
22.	C14	8.855	TERMINAL, BLO MTR GRD (2 530)	3033932
23.	D19	9.216	TUBE, MOTOR COOLING	3035192
24.	D20	9.275	SWITCH, PRESS CYCLING CUTOFF	3041596
25.		N.S.	GASKET, O-RING (PART OF 24)	
26.	D18	9.195	ACCUMULATOR, EVAP (1984)	2724312
	D18	9.195	ACCUMULATOR, DEHYDR (1985-88)	3059313
27.	D18	9.196	BRACKET, ACCUM (1984)	3052527
	D18	9.196	BRACKET, SUPT ACCUM (1985-88)	3057638
28.	D18	9.196	CLAMP, ACCUM TO MTG BRKT	3054104
29.		8.950	CLAMP, CLOSED LOOP (M22 2)	
30.	D19	9.213	ORIFICE, W GSKT (1984-85)	3033879
31.		8.927	O-RING, NEOPRENE (RED)(3/4" FITTINGS-CAPTURED)	3093411
32.	D18	9.211	SEAL, EVAP CORE	3052159
33.	D18	9.210	CORE, EVAP (1984)	3054185
	D18	9.210	CORE, EVAP (1985-88)	3090045
34.	D18	9.210	FILTER, EVAP WATER	3090870
35.	C13	8.854	COVER, HTR CORE-W/BRKT	3090992
	C13	8.854	GASKET, HTR CORE CVR TO CASE	3056496
36.	C13	8.854	CLIP, HTR CORE MTG	3053735
37.		8.950	CLIP, CLOSED LOOP TUBE 7/8" HOLE 13/32"	2041644
		8.977	SCREW, HWH TAP (M4 2X1 41X16)	11509374
38.		8.948	CLAMP, DRAIN TUBE (31 TO 75 DIA ZC CHR)	477402
39.		N.S.	TUBE, EVAP CASE DRAIN	
40.	D18	9.211	DRAIN, EVAP CASE SUMP	3053704
	D18	9.211	GASKET, SUMP DRAIN TO EVAP CASE	3056496
41.	C13	8.854	SEAL, HTR CORE (9 211)	3052253
42.	C13	8.854	SEAL, HTR CORE TUBE	3052160
43.	C13	8.854	CORE, HEATER	3052427
44.	C13	8.854	STRAP, HTR CORE MTG	3052411
45.	E6	9.787	BRACKET, TEMP VLV CBL MTG	3052316
46.	C13	8.854	CASE, HTR CORE-W-BFL	3053981
47.	E5	9.786	LEVER, TEMP VLV CONT	3052165
48.	E5	9.786	RETAINER, LINK	1484109
49.	E8	9.789	ACTUATOR, AIR INL (ELECT)	3052050
50.	E5	9.786	LINK, AIR INL VLV ADJ W SPR	3052416
51.	E6	9.789	ACTUATOR, MODE (ELECT)	3052051
52.	E5	9.779	SHAFT, DEFR VLV-W-LVR	3052166

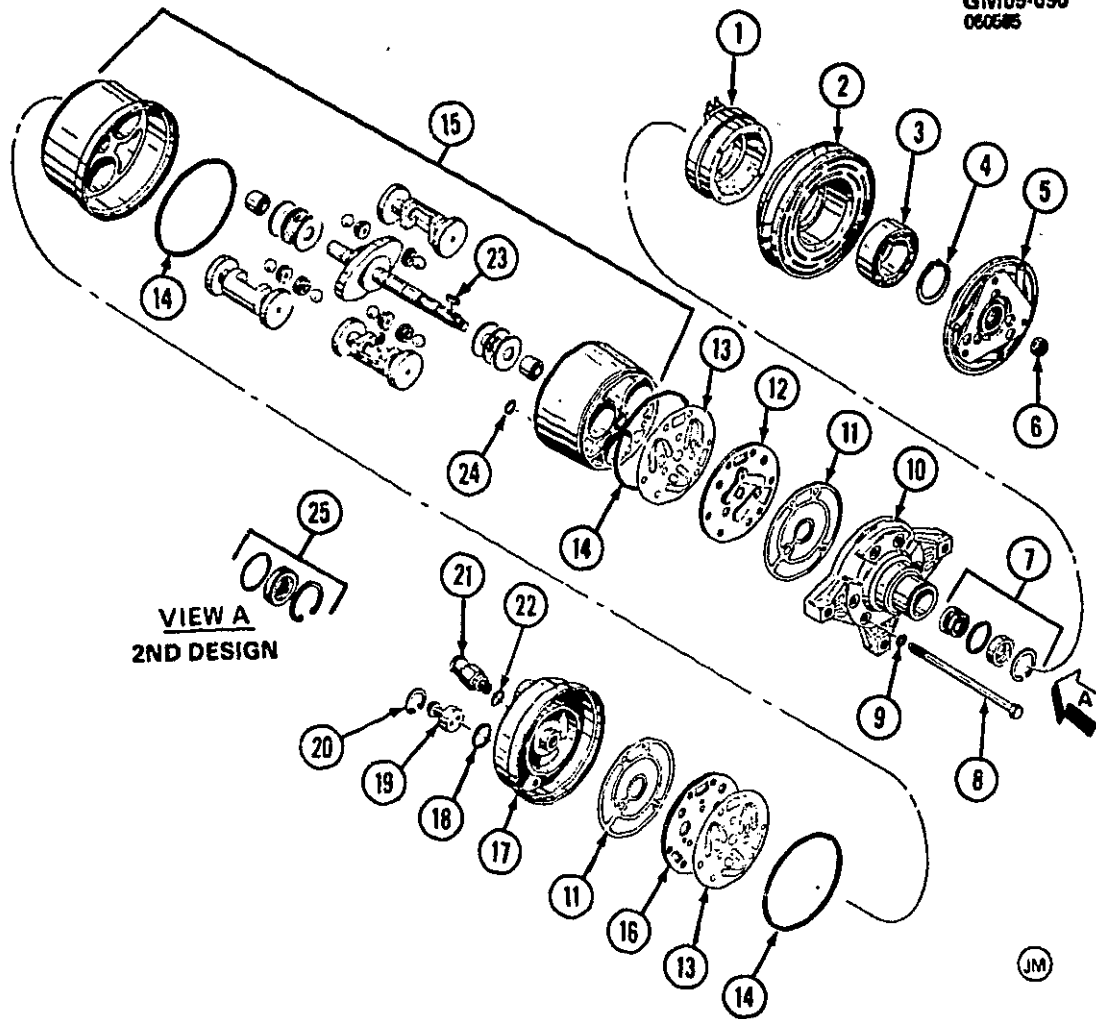

GM09-090

1984-1988 P A/C COMPRESSOR ASM DA-6/HR-6

NOTE SEE CHART IN GROUP FOR USAGE

1.	D18	9.186	COIL, W HSG
2.	D18	9.180	PULLEY, W BEARING
3.	D18	9.181	BEARING, PULLEY
4.	D18	9.181	RING, PUL BRG TO HD RET
5.	D18	9.188	CLUTCH, DRIVE
6.	D18	9.181	NUT, SHAFT
7.	D13	9.170	SEAL KIT, SHAFT (1984 1ST DES & PRIOR)(*2)
8.	D17	9.175	BOLT, CMPR HD
9.	D17	9.175	GASKET, HD BOLT(*1)
10.	D17	9.174	HEAD, CMPR FRT
11.	D17	9.175	GASKET, HD
12.	D17	9.172	PLATE, DISCHARGE VALVE FRT
13.	D17	9.172	REED, VALVE SUC
14.	D17	9.175	O RING, CYL TO HD(*1)
15.	D13	9.170	CYLINDER, W/SHAFT
16.	D17	9.172	PLATE, DISCHARGE VALVE RR
17.	D17	9.174	HEAD, CMPR RR
18.	D17	9.172	O-RING, SWITCH(*1)
19.	D20	9.275	SWITCH KIT, HI PRESS CUTOFF (INCLS #18 20)

19.	D20	9.275	SWITCH KIT, HI SI LOW PRESS (INCL #18.20)
	D17	9.172	SWITCH, FAN KIT (INCL #18.20)
20.	D17	9.172	RETAINER, SW RR CMPR HD
21.	D18	9.178	VALVE, PRESS REL
22.		8.927	O-RING, RELIEF VALVE(*1)
23.	D18	9.188	KEY, CLUTCH HUB
24.	D13	9.170	O-RING, CYL DISCHARGE(*1)
25.	D13	9.170	SEAL KIT, SHAFT (BEGINNING W/1984 2ND DES)*2)

NOTE 1 GROUP 9 175 RING & SEAL KIT #2724281 INCLUDES #9.14.18.22.24

NOTE 2 1ST DES 6599114 USED IN ALL MODELS PRIOR TO 1984 & 1984 ASM NUMBERS

1131400,1131407,1131409,1131413. 2ND DES 2724319 USED IN ALL OTHER 1984 ASSEMBLIES
& LATER

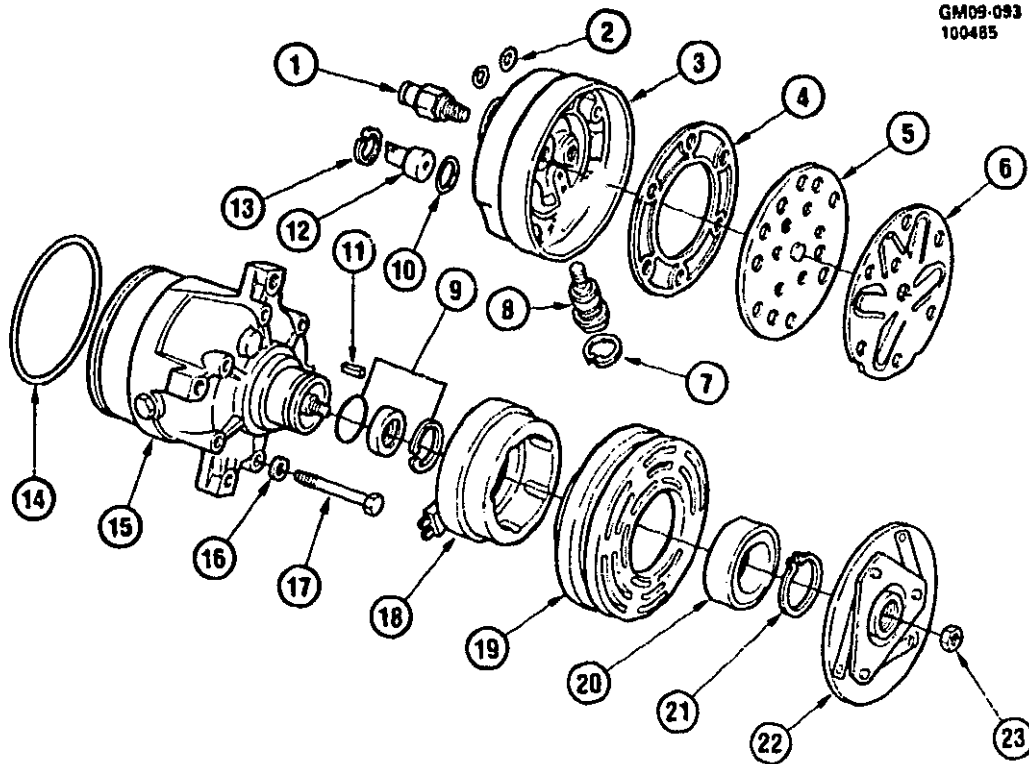

GM09-093

1986-1988 P A/C COMPRESSOR ASM/V-5

NOTE FOR SPECIFIC APPLICATION SEE CHART GROUP 9 170 OF THE PARTS CATALOG

1.	D18	9.178	VALVE, PRESS RLF
2.	D19	9.222	SEAL, SUC DISCHARGE PORTS
3.	D17	9.174	HEAD, CMPR RR
4.		N.S.	GASKET, RR HEAD
5.		N.S.	PLATE, VALVE
6.		N.S.	REED, SUCTION
7.	D17	9.176	RETAINER, W/O-RING CONT VLV
8.	D17	9.176	CONTROL, VALVE
9.	D13	9.170	SEAL KIT, SHF (INCLS LIP SEAL O-RING RETAINING RING)
10.	D17	9.172	O-RING, SWITCH
11.	D18	9.188	KEY, CLU HUB
12.	D17	9.172	SWITCH KIT, CUT-OUT (2 TERM)
13.	D17	9.172	RETAINER, FAN OR CUT-OUT SWITCH
14.	D17	9.175	O RING, RR HEAD
15.		N.S.	HOUSING, COMPRESSOR(*))
16.	D17	9.175	GASKET, HD BOLT
17.	D17	9.173	GASKET KIT, W/BOLT VLV (INCLS #16)
18.	D18	9.186	COIL, W/HSG
19.	D18	9.180	PULLEY, W/ROTOR & BRG
20.	D18	9.181	BEARING, PULLEY
21.	D18	9.181	RING, PUL BRG TO FRT HEAD
22.	D18	9.188	CLUTCH, DRIVE
23.	D18	9.181	NUT, SHAFT

NOTE 1 THE HOUSING IS PART OF THE COMPRESSOR

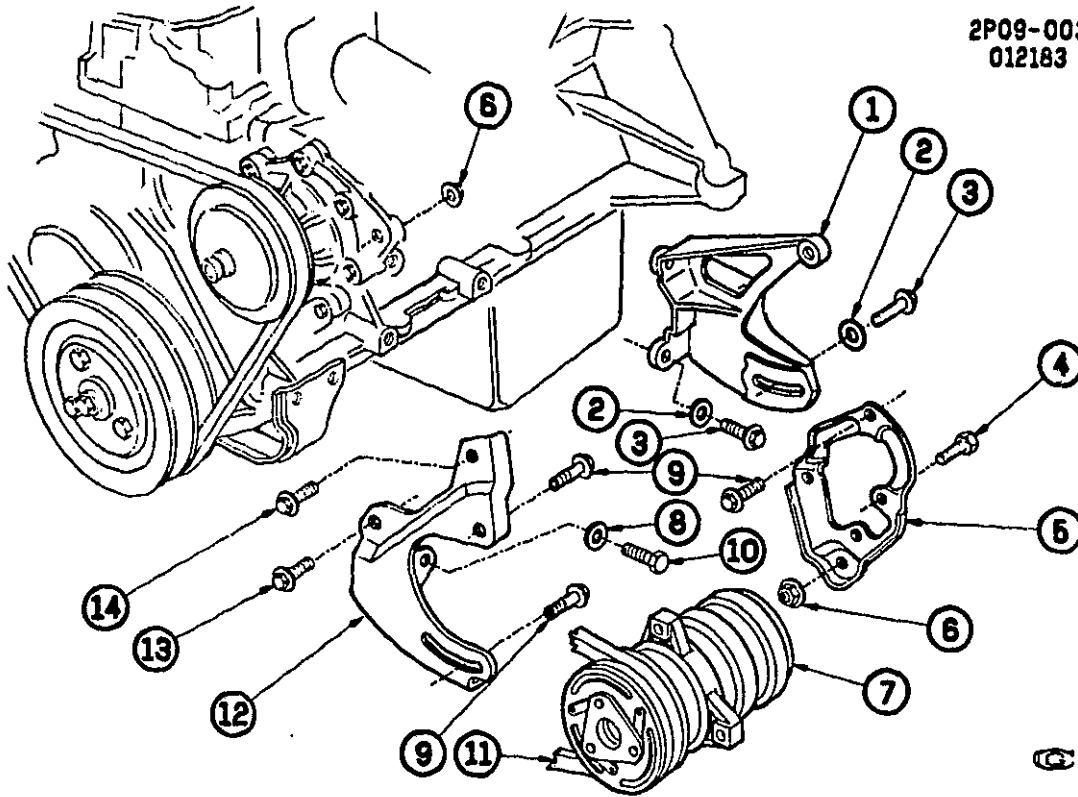

2P09-003

1984-1985 P A/C COMPRESSOR MOUNTING-2.5L L4 (LR8 W/W72)

1.	D17	9.171	BRACKET, CMPR RR ADJ	10022911
2.		8.929	WASHER, FLAT (M10 X 25)	
3.		8.900	BOLT, HWH (M10 X 1 5 X 35)	
4.		8.900	BOLT, HEX (M8 X 1 25 X 20)	
5.	D17	9.171	BRACKET, CMPR RR	10022937
6.		8.917	NUT, HWH (M10 X 1 5)	
7.	D13	9.170	COMPRESSOR, A/C	12329837
8.		8.929	WASHER, FLAT (M10 X 20)	
9.		8.900	BOLT, HWH (M10 X 1 5 X 25)	
10.		8.900	BOLT, HEX (M10X1 5X30; 10 9 PC)	
11.	N7	1.066	BELT, A/C CMPR (7/16" X 38")	9433728
12.	D17	9.171	BRACKET, CMPRFRT	10022878
13.		8.900	BOLT, HWH (M10 X 1 5 X 30)	
14.		8.900	BOLT, HWH (M10 X 1 5 X 40)	

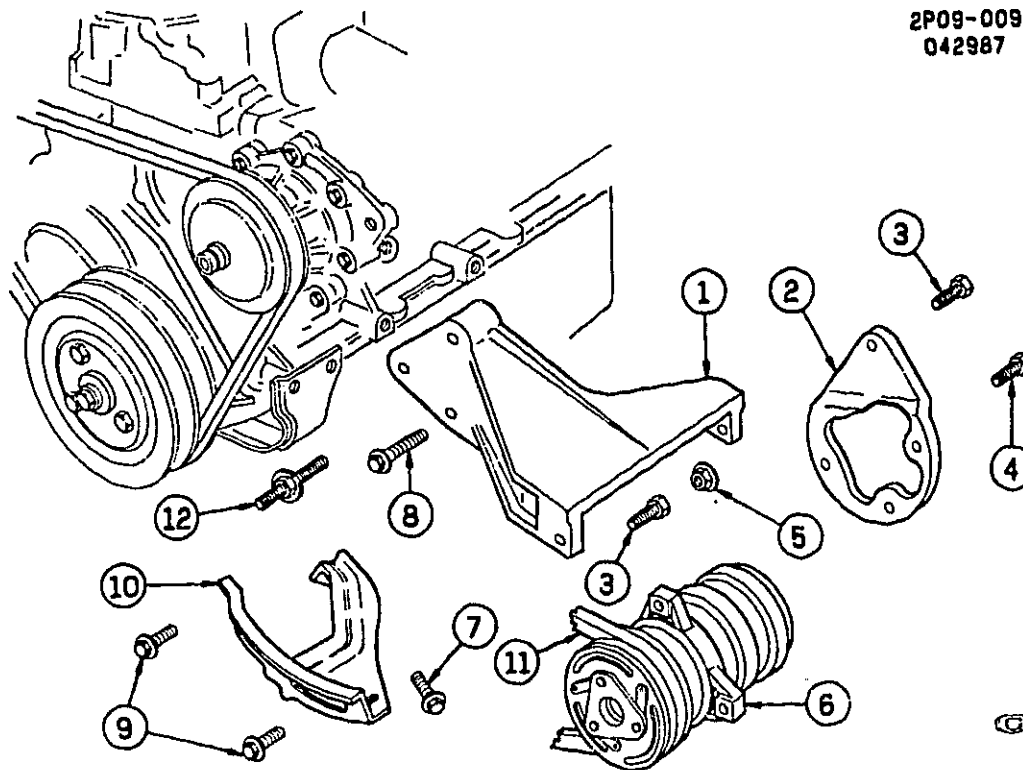

2P09-009

1985-1988 P A/C COMPRESSOR MOUNTING-2.8L V6 (L44/2.8-9)

1.	D17	9.171	BRACKET, A/C CMPR PIVOT	10032582
2.	D17	9.171	BRACKET, A/C CMPR RR	10032577
3.		8.900	BOLT, HFH (M10X1 5X35)(6 008)	14056185
4.		8.900	BOLT, HFH (M8X1 25X18)	11508280
5.		8.917	NUT, HEX FLG (M10-1 5)	11508101
6.	D13	9.170	COMPRESSOR, A/C	12329637
7.		8.900	BOLT, HFH (M10X1 5X30)	11502689
8.		8.900	BOLT, HEX (M10X1 5X60)	11509285
9.		8.900	BOLT, HEX FLG (M10X1 5X20)	11502686
10.	D17	9.171	BRACKET, A/C CMPR ADJ (1985-87)	10032584
	D17	9.171	BRACKET, A/C CMPR ADJ (1988)	10044943
11.	N7	1.088	BELT, A/C CMPR (7/16"X37 1/2" HFH)	9433727
12.	D17	9.173	STUD, A/C CMPR BRKT (1 073)	1619032

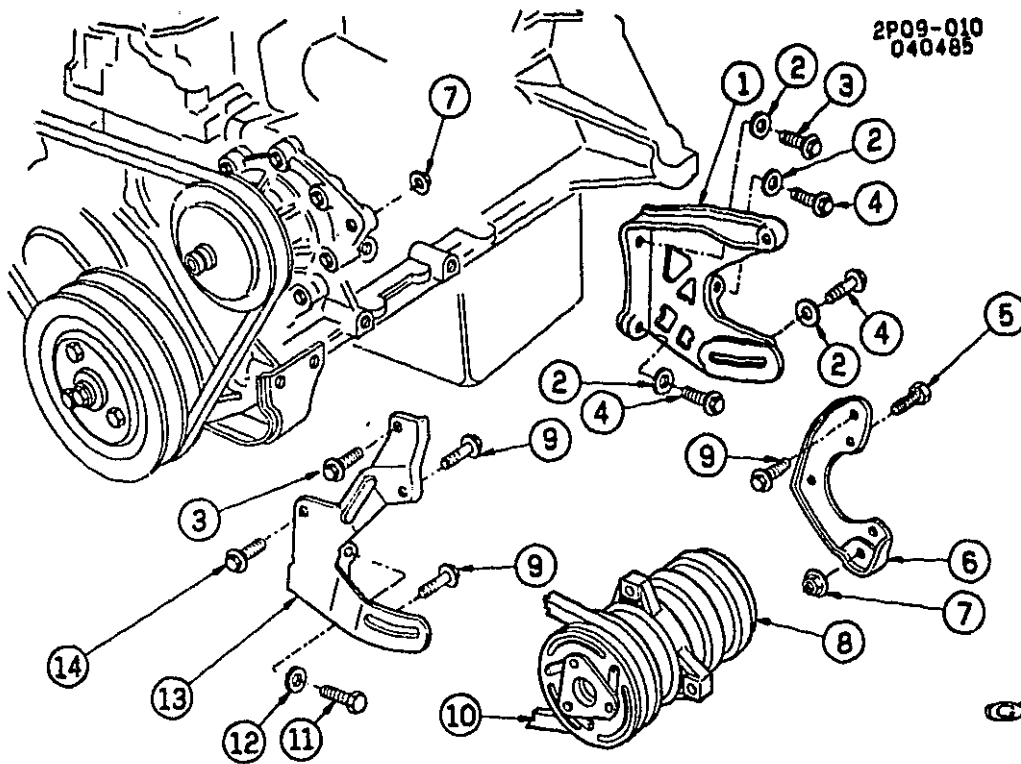

2P09-010

1986 P A/C COMPRESSOR MOUNTING-2.5L L4 (LR8/2.5R)

1.	D18	9.211	BRACKET, CMPR RR BRKT ADJ	10043002
2.		8.929	WASHER, (M10X25X3)	
3.	D17	9.173	BOLT, A/C CMPR ADJ BRKT FRT & RR(O 002)	11509844
4.		8.900	BOLT, HFH (M10X1 5X35)	
5.		8.900	BOLT, HFH (M8X1 25X20) 10 9 POB	11514343
6.	D18	9.211	BRACKET, CMPR RR	10037382
7.		8.917	NUT, HFH (M10X1 5X10)	11506101
8.	D13	9.170	COMPRESSOR, A/C	
9.		8.900	BOLT, HWH (M10-1 5X25)	
10.	N7	1.086	BELT, A/C CMPR(10 41MM X 1150MM)	10034695
11.		8.900	BOLT, HEX (M10X1 5X30) 10 9 PC	
12.		8.929	WASHER, FL (M10X20X3)	
13.	D18	9.190	BRACKET, CMPR FRT ADJ	10037383
14.		8.900	BOLT, HFH (M10X1 5X30)	

2P09-011
111286

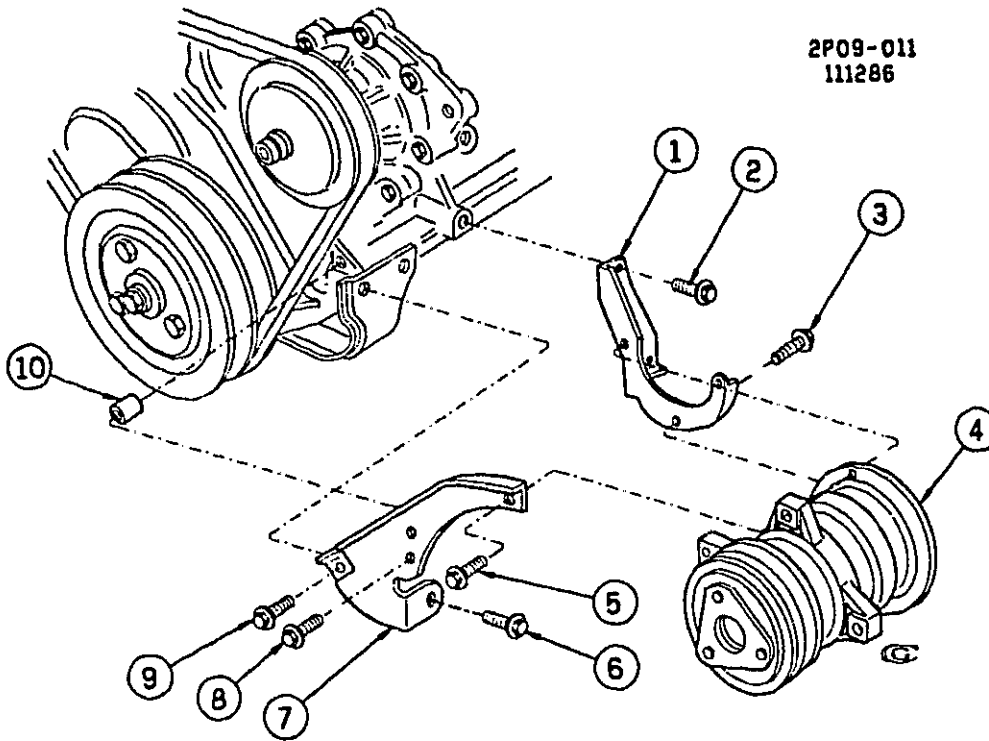

2P09-011

1987-1988 P A/C COMPRESSOR MOUNTING-2.5L L4 (LR8/2.5R)

1. D17	9.171	BRACKET, CMPR RR	10043088
2.	8.900	BOLT, HFH (M10X1 5X20) 9 8 PC	11502885
3.	8.900	BOLT, LRG HFH (M10X1 5X30) 9 8 P	11502889
4. D13	9.170	COMPRESSOR, A C	12328618
5.	8.900	BOLT, LRG HFH (M10X1 5X30) 9 8 P	11502889
6. N9	2.277	SCREW, W/SPL WA HEX HD (M10X1 5)	10008894
7. D17	9.171	BRACKET, CMPR ADJ FRT	10041245
8.	8.900	BOLT, HEX (M10X1 5X50) 9 8 PC	1254879
9.	8.900	BOLT, HWH (M10X1 5X25) 10 9 PH	11502788
10. D17	9.171	SPACER, CMPR FRT ADJ BRKT	527348

2P09-006
013184

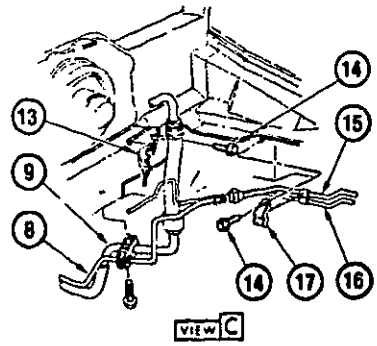
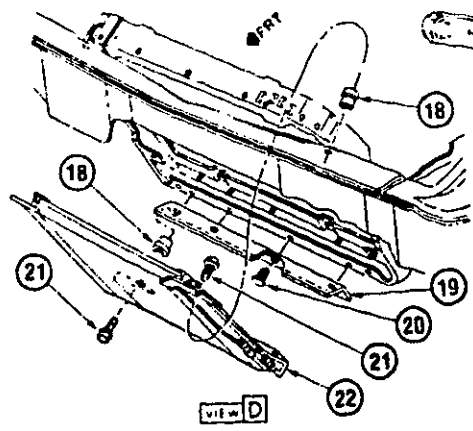
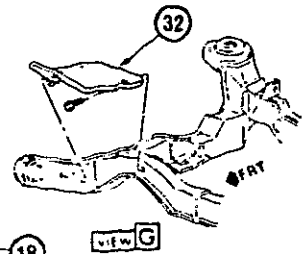
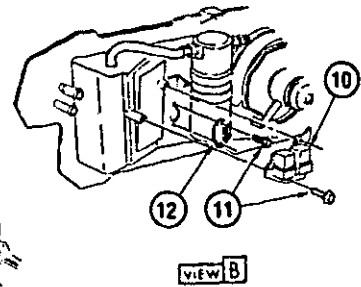
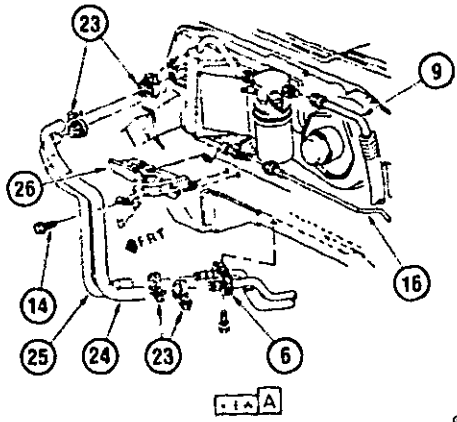
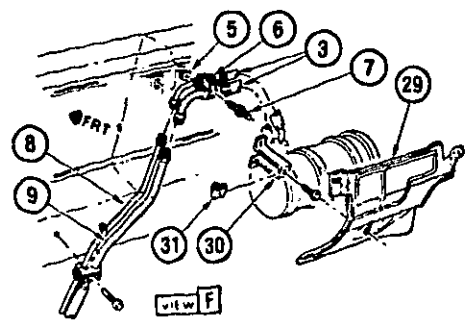
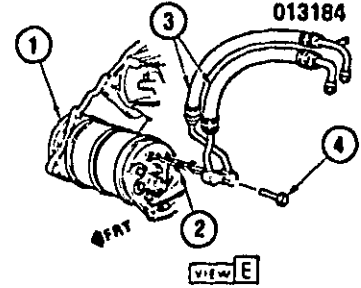
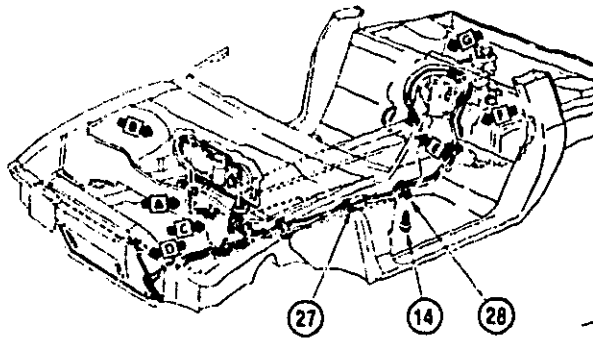

2P09-006

1984 P A/C REFRIGERATION SYSTEM

1.	D13	9.170	COMPRESSOR, A C	12329637
2.	D19	9.222	SEAL, SUC DISC PORTS	6556587
3.	D19	9.226	FITTING, COMPL W/HOSES (1ST DES # STMPD ON HOSE)	10032120
	D19	9.226	FITTING, COMPL W/HOSES (2ND DES # STMPD ON HOSE)	10032120
4.		8.900	BOLT, HWD (M10 X 1 5 X 35)	
5.		8.921	NUT, 3/8" SQ HOLE 1/4" HD 5/8" SQ NYLON	
6.		8.965	STRAP, PLASTIC 7" ADJ	
7.		8.977	BOLT, HWD TOP (M6 3 X 1 81 X 35)	
8.	D19	9.220	TUBE, CMPR OTLT (UNDERBODY)	10031415
9.	D19	9.220	TUBE, CMPR INLT (UNDERBODY)	10031414
10.	D20	9.277	RELAY, A C HI BLO	10026663
	D20	9.277	BRACKET, BLO MTR RELAY	10026849
11.		8.977	SCREW, HEX TAP (M4 2 X 1 41 X 13)	
12.	D20	9.275	RESISTOR, BLO MTR	10030701
13.	C8	8.160	SEAL, FRT COMPT PAN OPNG TO TORQ BAR-LH	10024168
14.		8.977	SCREW, HWD TAP (M6 3 X 1 81 X 16)	
15.	D17	9.172	TUBE, CMPR OTLT FRT (1985-87)	10021313
	D17	9.172	TUBE, CMPR OTLT FRT (1988)	10059150
16.	D19	9.220	TUBE, A C MODULE TO COND (1985-87)	10021315
	D19	9.220	TUBE, A C MODULE TO COND (1988)	10080277
17.	D18	9.211	CLIP, EVAP TUBE TO FRT SI RAIL	10024163
18.	D19	9.242	NUT, M6 X 1 THD BRASS/RUB	10027795
19.	N8	1.274	SEAL, RAD AIR LWR TO CNDSR	10023641
20.	N21	12.801	RETAINER, PNL HOLE (DIA 1/4" THK 3/8")	480534
21.		8.900	SCREW, HEX (M6 X 1 X 25) W/CON WA	
22.	D18	9.190	CONDENSER, A.C	3050988
23.		8.948	CLAMP, WORM TYPE (3/4" TO 1-3/4")	
24.	C13	8.846	HOSE, HTR OTLT (TO MOD)	10024166
25.	C13	8.846	HOSE, HTR INL (TO MOD)	10024158
26.	N26	12.981	SEAL, FRT COMPT PAN OPNG TO TORQ BAR-LH	10029215
27.	D17	9.171	SHIELD, COMPR TUBE (TO ST BELT ANC BOLT)	10026096
28.	D18	9.211	CLAMP, CNDSR & EVAP TUBE (TO U/B)	10031273
29.	D19	9.226	SHIELD, A/C CMPR	10038127
30.	D19	9.226	BRACKET, SHIELD	10032118
31.		8.921	NUT, SPR (M8 X 1 25-TYPE C)	
32.	D17	9.171	SHIELD, CMPR SPH	10038173

2P09-008
080690

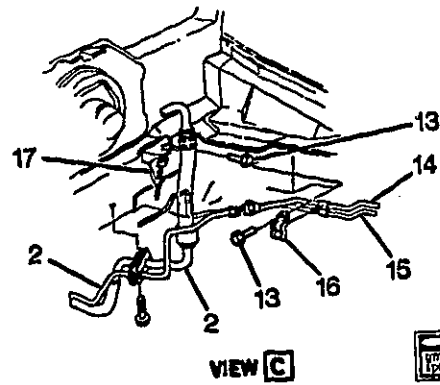
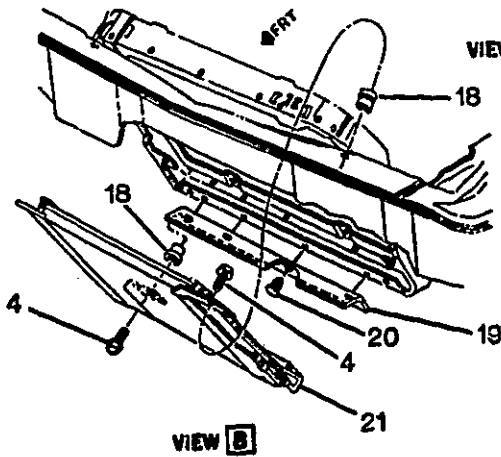
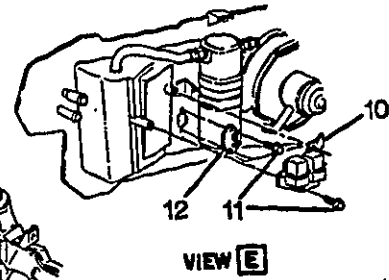
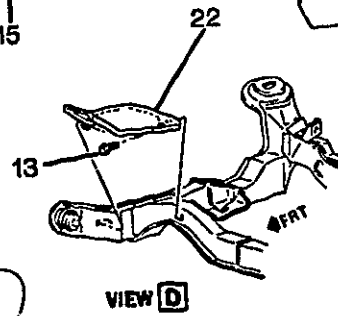
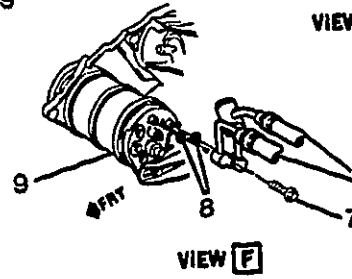
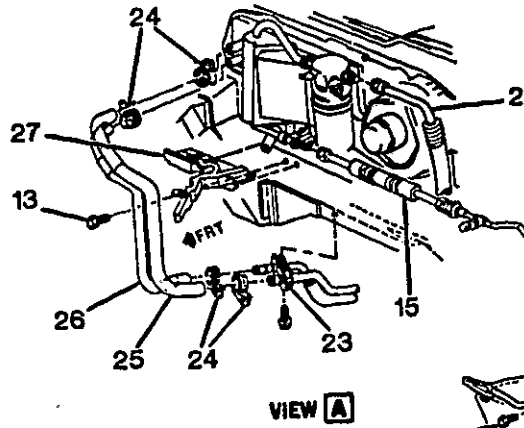
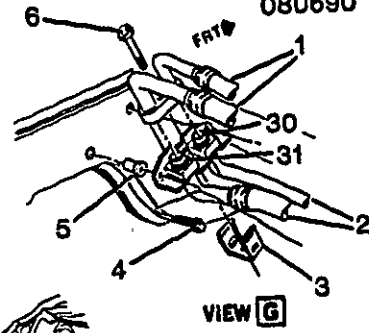
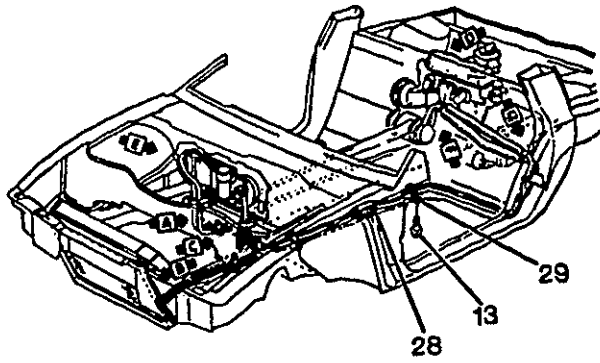

2P09-008

1985-1987 P A/C REFRIGERATION SYSTEM

1.	D19	9.226	FITTING, COMPL-W/HOSES (1985 2 5R)	10039870
	D19	9.226	FITTING, COMPL-W/HOSES (1986 2 5R)	10089701
	D19	9.226	FITTING, COMPL-W/HOSES (1987 2 5R)	10075022
	D19	9.226	FITTING, COMPL-W/HOSES (W/2 8-9)	10034325
2.	D19	9.220	TUBE, CMPR INLT/OTLT (INCLS #3.8)(1985-86)	10038835
	D19	9.220	TUBE, CMPR	10041714
3.		8.921	NUT, U-SHAPE MULTI THRD SPG (M6X1X6 3)	11513918
4.		8.900	BOLT, HEX W/CON SPR WA (M6X1X25)(9 8 PZOR)	20351035
5.	D19	9.242	NUT, THD BRASS/RUB (M6X1)	10027795
6.		8.900	SCREW, HWH (M6X1X50) 9 8 PC	11503796
7.		8.900	BOLT, HEX (M10X1 5X35) 10 9 PC	11500931
8.		8.927	O-RING, NEOPRENE (RED)(1/2" FITTINGS-CAPTURED)	3093112
		8.927	O-RING, NEOPRENE (RED)(3/4" FITTINGS-CAPTURED)	3093411
9.	D13	9.170	COMPRESSOR, A/C (1985 2 5R)(*2)	12332884
	D13	9.170	COMPRESSOR, A/C (1985-87 2 8-9)(*1)	12329837
10.	D20	9.277	RELAY, A/C HI BLO (3 140)(1985-86)	10028863
	C14	8.855	RELAY, BLO MTR (1986-87)	10040835
	D20	9.277	BRACKET, BLO MTR RLY	10028849
11.		8.977	SCREW, HEX TAP (M4 2X1 41X13)	11508256
12.	D20	9.275	RESISTOR, BLO MTR	10039031
13.		8.977	BOLT, HEX W/FL WA (M6 3X1 81X20) PZOR	12337828
14.	D17	9.172	TUBE, CMPR OTLT FRT	10021313
15.	D19	9.220	TUBE, A/C EVAP TO EVAP	10080277
16.	D18	9.211	CLIP, EVAP TUBE TO FRT SI RAIL	10024163
17.	C8	8.160	SEAL, FRT COMPT PAN A/C CMPR HOSE OPG	10024168
18.	D19	9.242	NUT, THD BRASS/RUB (M6X1)	10027795
19.	N8	1.274	SEAL, RAD AIR LWR TO CNDSR	10023641
20.	N21	12.801	RETAINER, PNL HOLE (DIA 1/4" THK 1/32")	480534
21.	D18	9.190	CONDENSER, A/C	3050888
22.	D17	9.171	SHIELD, CMPR SPH	10038173
23.		N.S.	CLAMP,	
24.		8.948	CLAMP, WORM GEAR (62 TO 1 25)	12337891
25.	C13	8.846	HOSE, HTR OTLT (TO MOD)(1985-86)	10024166
	C13	8.846	HOSE, HTR OTLT (1987)	14101517
26.	C13	8.846	HOSE, HTR INL (TO MOD)(1985-86)	10024168
	C13	8.846	HOSE, HTR INL (1987)	14101515
27.	N26	12.981	SEAL, FRT COMPT PAN A/C CMPR HOSE OPG	10029215
28.	D19	9.220	SHIELD, A/C CMPR TUBE	10041707
29.	D18	9.211	CLAMP, CNDSR & EVAP TUBE(TO U/B)	10031273
30.		8.927	O-RING, NEOPRENE (RED)(1/2" FITTINGS-CAPTURED)	3093112
31.		8.927	O-RING, NEOPRENE (RED)(3/4" FITTINGS-CAPTURED)	3093411

NOTE 1 1ST DESIGN HAS 4 9" PULLEY

NOTE 2 2ND DESIGN HAS 5 7" PULLEY

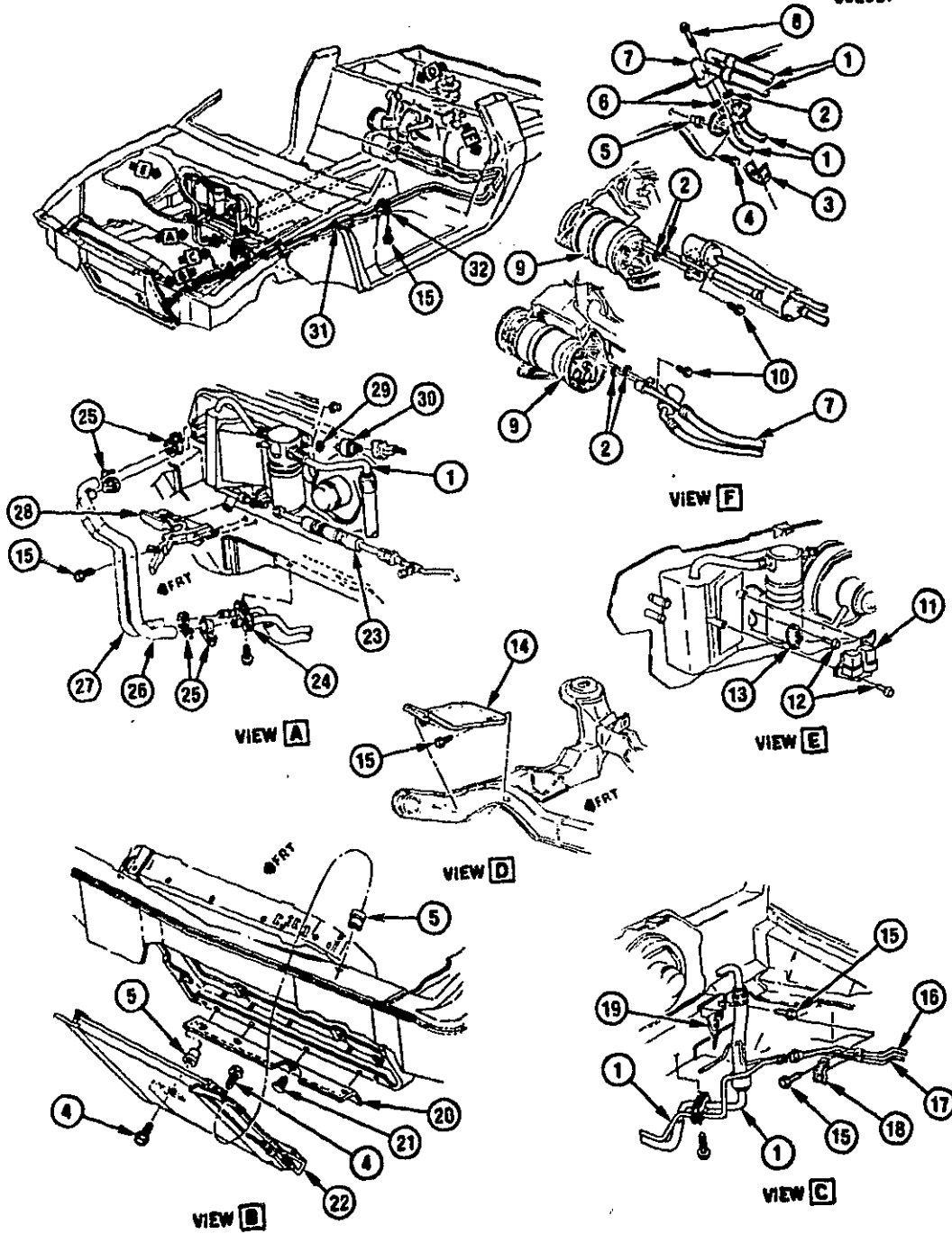

1988 P A/C REFRIGERATION SYSTEM

1.	D19	9.220	TUBE, A/C CMPR	
2.		8.927	O-RING, NEOPRENE (RED)(1/2" FITTINGS-CAPTURED)	3093112
3.		8.921	NUT, U SHAPED (M6X1X20X24)POR 1010 STL POR	22538012
4.		8.900	BOLT, HEX W/CON WA (M6X1X25)9 8 PZOR	20351035
5.	D19	9.242	NUT (M6X1) THD BRASS/RUB	10027795
6.		8.927	O-RING, NEOPRENE (RED)(3/4" FITTINGS-CAPTURED)	3093411
7.	D19	9.226	FITTING, COMPL W/HOSES (2 5R)	10075022
	D19	9.226	FITTING, COMPL W/HOSES (2.8-9)	10034325
8.		8.900	BOLT, HWH (M10X1 5X35)10 9 POR	14056165
9.	D13	9.170	COMPRESSOR, A/C (W/O PULLEY)	2724405
10.		8.900	BOLT, HEX (M10X1 5X35)10 9 PS	11513808
11.	C14	8.855	RELAY, BLO MTR	10040835
	D20	9.277	RELAY, A/C HI BLO (3 140)	10026663
12.		8.977	SCREW, HWH (M4 2X1 41X13)POR	11508258
13.	D20	9.275	RESISTOR, BLO MTR	10039031
14.	D17	9.171	SHIELD, CMPR SPH	10038173
15.		8.977	BOLT, HEX W/FL WA (M6 3X1 81X20)8010M PZOR	12337828
16.	D17	9.172	TUBE, A/C CMPR OTLT FRT	10069150
17.	D19	9.220	TUBE, A C MODULE TO COND (1988)	10080277
18.	D18	9.211	CLIP, EVAP TUBE TO FRT SI RAIL	10024163
19.	C8	8.160	SEAL, FRT COMPT PAN A/C CMPR HOSE OPG-LH	10024168
20.	N8	1.274	SEAL, RAD AIR LWR TO CNDSR	10023641
21.	N21	12.801	RETAINER, PNL HOLE (DIA 1/4" THK 1/32")	480534
22.	D18	9.190	CONDENSER, A/C	3050988
23.	D19	9.220	TUBE, A.C. MODULE TO COND (1988)	10080277
24.		N.S.	CLAMP	
25.		8.948	CLAMP, WORM GEAR (15 7 TO 31 8)SS	22537533
26.	C13	8.846	HOSE, HTR OTLT	10089158
27.	C13	8.846	HOSE, HTR INL	10089156
28.	N26	12.981	SEAL, FRT COMPT PAN A/C CMPR HOSE OPG-RH	10029215
29.	D18	9.178	SEAL, PRESS RLF VLV	52450548
30.	D20	9.275	SWITCH, PRESS CYCLING CUTOFF	3041596
31.	D19	9.220	SHIELD, A/C CMPR TUBE	10041707
32.	D18	9.211	CLAMP, CNDSR & EVAP TUBE	10031273

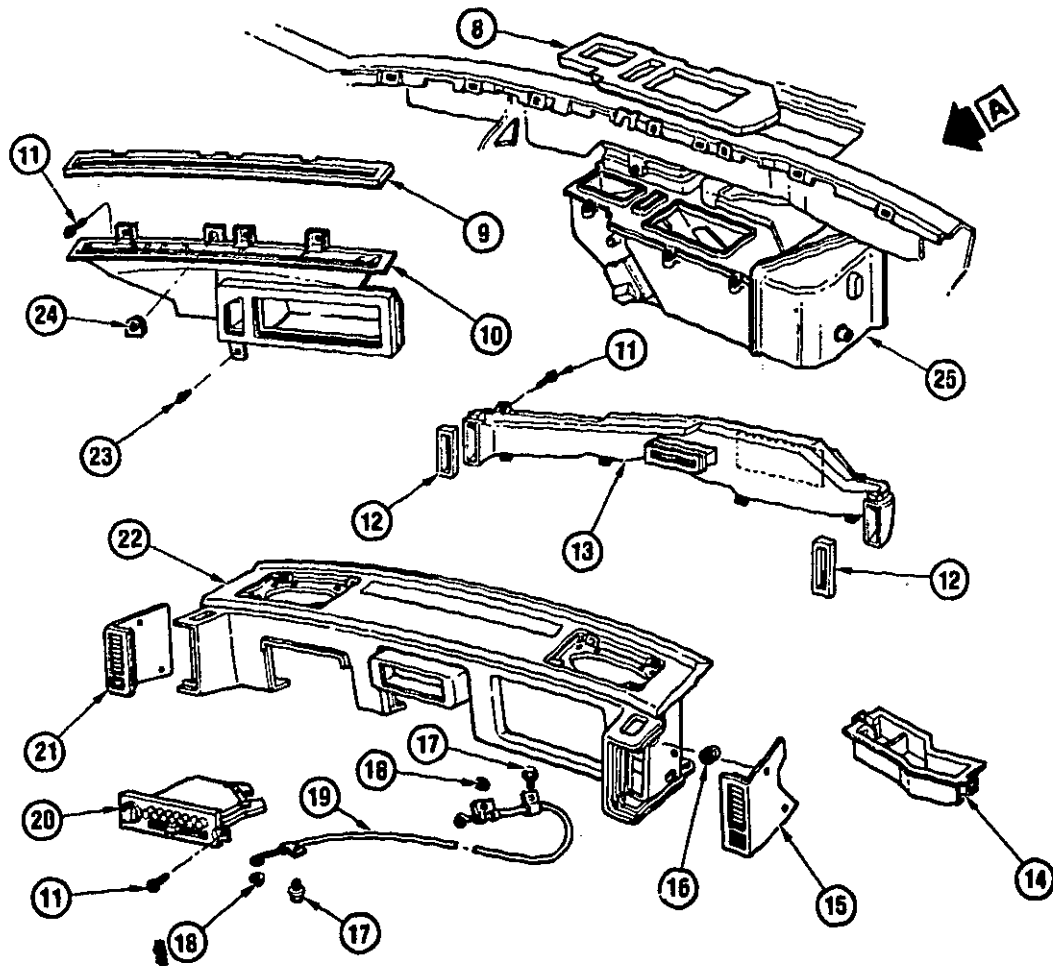
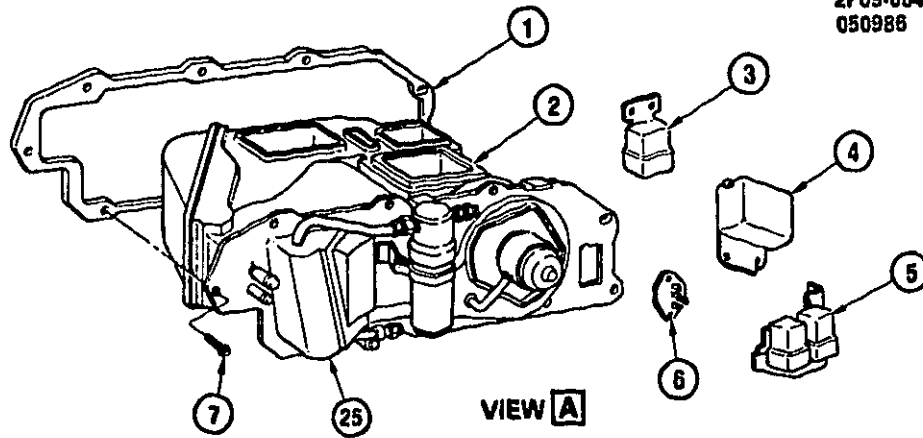

1984-1988 P A/C AIR DISTRIBUTION SYSTEM

1.	D20	9.262	GASKET, BLO MOD TO DASH	3052129
2.	D18	9.211	GASKET, HTR BLO MTR	10033693
3.	D20	9.277	RELAY, A/C CONT	10034222
	D20	9.277	BRACKET, A/C CONT RLY (1984)(3 900)	10022615
	D20	9.277	LATCH, A/C CONT RLY (3 900)	10023153
4.	E5	9.778	RELAY, ELEC RR WDO DEFG	10026005
5.	D20	9.277	RELAY, HTR HI BLO (3 140)	10026863
	D20	9.277	BRACKET, BLO MTR RLY (W/A C)	10026849
6.	D20	9.275	RESISTOR, BLO MTR (1984-85)	10030701
	D20	9.275	RESISTOR, BLO MTR (1986-87)	10039031
7.		8.977	SCREW, HEX TAP W/FL WA (M6 3X1 81X35)	499558
8.	E5	9.779	SEAL, INT DEFR DUCT TO MOD	10021274
9.	D20	9.262	SEAL, POLYURETHANE FOAM(*1)	3999511
10.	E5	9.779	DISTRIBUTOR, DEFG & AIR	10021266
11.		8.977	SCREW, HEX WA HD C/R TAP (M4 2X1 41X20) POR	22536997
12.	D20	9.262	SEAL, FOAM (46 5" X 36" X 5")(*1)	383139
13.	D20	9.262	DISTRIBUTOR, AIR DUCT	10021262
14.	D20	9.262	OUTLET, HTR AIR	10021273
15.	E15	10.252	PLATE, I/P TR-RH (GRAPHITE GRAY)(PAINT AS REOD)	10021232
16.		8.921	NUT, "U" SPR-THD SIZE 8 NYLON	
17.		8.977	SCREW, HWH TAP (M4 2X1 41X16) PZOR	11509135
18.		8.921	NUT, SPL PUSH-ON TYPE A (M3 6X11 23)(PHOS)	11501937
19.	E6	9.787	BOWDEN WIRE REPAIR (13' HSG & 60' WIRE)	6258364
20.	D20	9.273	CONTROL, HTR & A/C (1984)	16018322
	D20	9.273	CONTROL, HTR & A/C (1985-87)	16040702
21.	E15	10.252	PLATE, I/P TR-LH (GRAPHITE GRAY)(PAINT AS REOD)	10021233
22.	E14	10.235	PAD, I/P	10042617
23.		8.977	SCREW, HWH TAP (#8-18 X 1 0)	11504591
24.		8.921	NUT, SPECIAL (028 X 077 SLOT HOLE PLASTIC)	
25.		N.S.	MODULE ASM, A/C	

NOTE 1 CUT AS REQUIRED

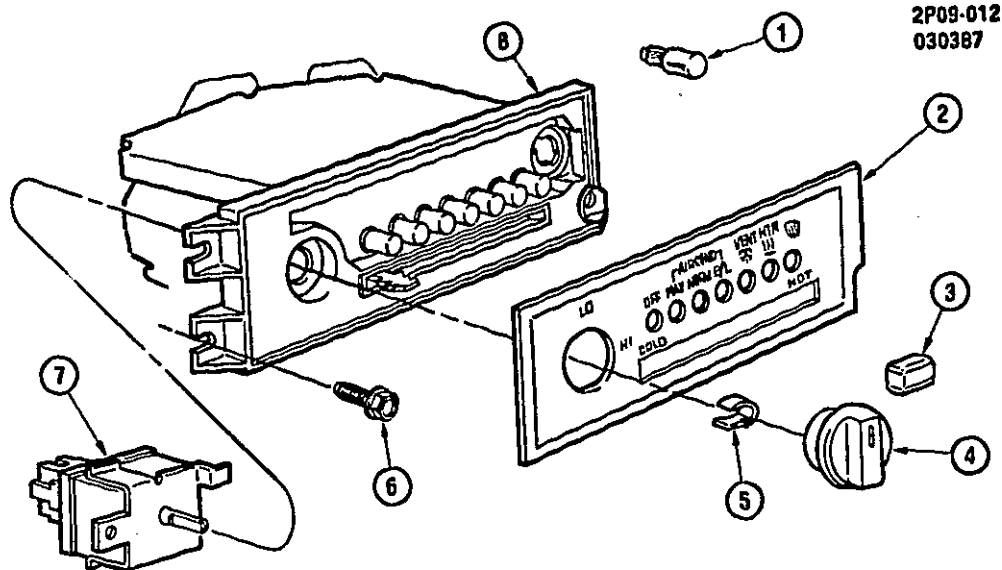

2P09-012
030387

2P09-012

1985-1988 P A/C & HEATER CONTROL ASM (C60)

1.	D20	9.279	LAMP, CONT DIAL(*1)	7895189
2.		N.S.	APPLIQUE(*2)	
3.	D20	9.278	KNOB, TEMP(*1,2)	1228395
4.	C13	8.852	KNOB, BLOWER (8.852)(*1,2)	16039103
5.	D20	9.275	SPRING, BLO KNOB (8.852)(*1)	16014896
6.		N.S.	SCREW(*1)	
7.	D20	9.275	SWITCH, FAN (8.852)(*1)	16023827
8.		N.S.	HOUSUNG(*1,2)	

NOTE 1 PART OF GROUP 9 273 CONTROL ASM PART #16040702

NOTE 2 PART OF GROUP 9 279 DIAL KIT PART #1226955

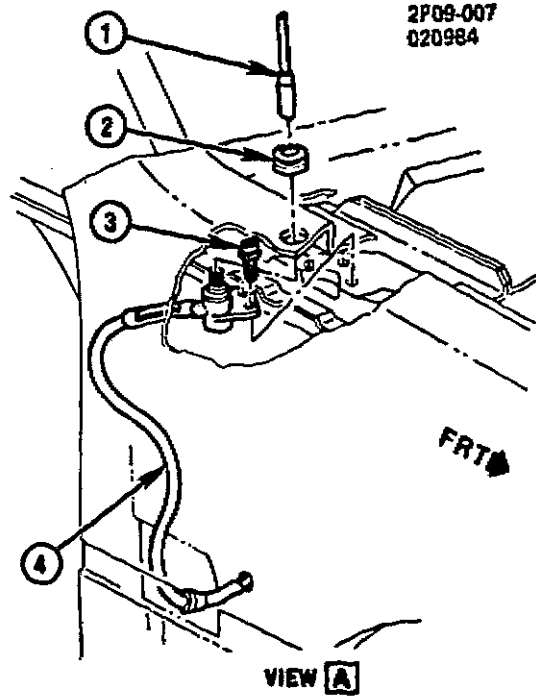
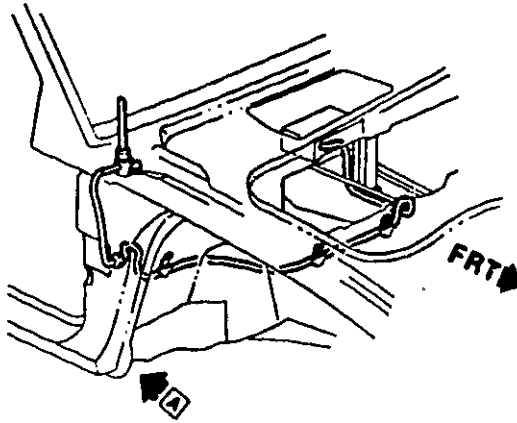

2P09-007

1984-1988 P ANTENNA ASM/FIXED MAST

1.	D20	9.647	ANTENNA, RDO
2.	D20	9.647	INSULATOR, ANT
3.		8.977	SCREW, HWH (M4 7 X 1 59 X 13)
4.	D20	9.647	CABLE, ANT

10149422
10036925
22506732
10031802

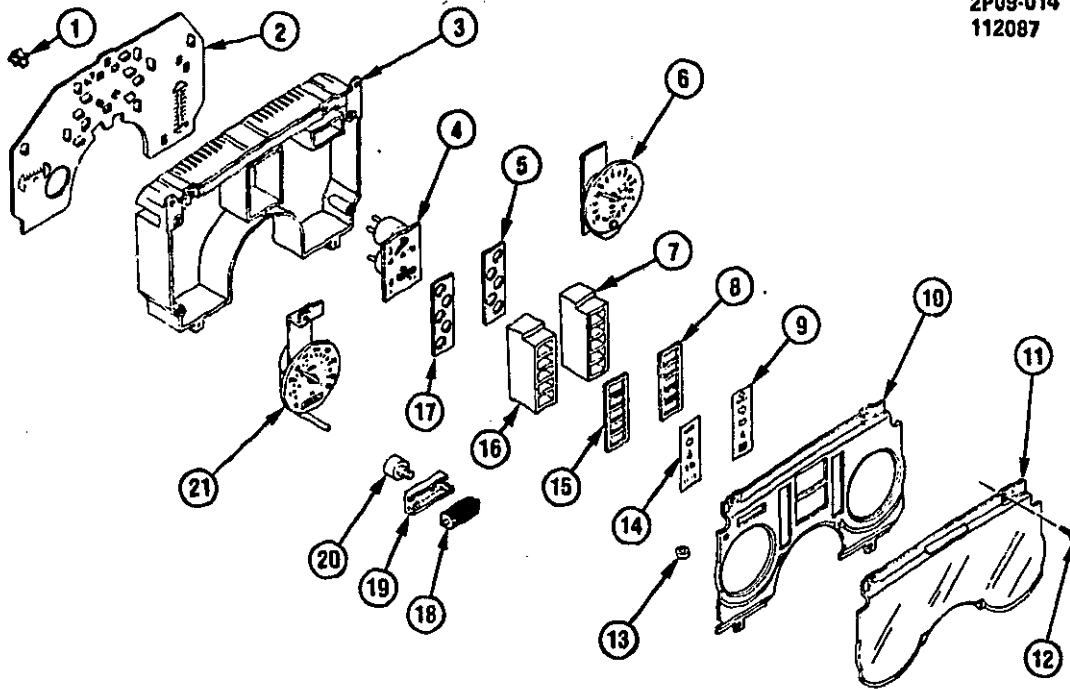

2P09-014

1988 P CLUSTER ASM/INSTRUMENT PANEL

1.	E4	9.744	CLIP, GAGE	8986000
2.	E4	9.744	PRINTED CIRCUIT	25077762
3.	E4	9.744	CASE, CSTR	25081258
4.	N12	3.108	GAGE, FUEL/TEMP (1.148)	25079182
5.	E4	9.744	GASKET, HOUSING-RH	25076637
6.	E4	9.750	GAGE, TACH/OIL (1.803)	25059578
7.	E4	9.748	HOUSING, TELLTALE-RH	25083226
8.	E4	9.761	GASKET, HOUSING-RH (FILTER TO CASE)	25080398
9.	E4	9.748	FILTER, LIGHT IND-RH	25083301
10.	E4	9.747	RETAINER, INST CSTR LENS	25048138
11.	E4	9.748	LENS, CSTR	25048135
12.	E4	9.743	SCREW (3.5X1.34X12.70M)	25044356
13.	E4	9.761	BUSHING, LOC (BETWEEN LENS & CSTR CASE)	25048668
14.	E4	9.748	FILTER, LIGHT-LH	25079160
15.	E4	9.761	GASKET, CASE-LH	25080397
16.	E4	9.748	HOUSING, TELLTALE-LH	25083225
17.	E4	9.744	GASKET, HOUSING-LH (BULB TO CASE)	25076638
18.	E4	9.761	ODOMETER	25058252
19.	E4	9.761	RETAINER, ODOM	25058126
20.	E4	N.S.	STEPPER MOTOR	
21.	E4	9.761	SPEEDOMETER	

PONTIAC BODY GROUP 10.000

ILLUSTRATION INDEX

	TITLE	GRID
1984-1987	P WIPER SYSTEM/WINDSHIELD	K4
1988	P WIPER SYSTEM/WINDSHIELD	K5
1984-1988	P WIPER MOTOR/WINDSHIELD (DELCO)(PULSE)	K6
1984-1988	P WIPER MOTOR/WINDSHIELD (DELCO)	K7
1984-1988	P MIRRORS/REAR VIEW-EXTERIOR	K8
1984-1986	P INSTRUMENT PANEL	K10
1986-1988	P INSTRUMENT PANEL	K11
1984-1985	P CONSOLE/FLOOR	K14
1986-1987	P CONSOLE/FLOOR	K17
1988	P CONSOLE/FLOOR	K19
1984-1988	P DOOR HARDWARE/FRONT	K21

2P10-008
050785

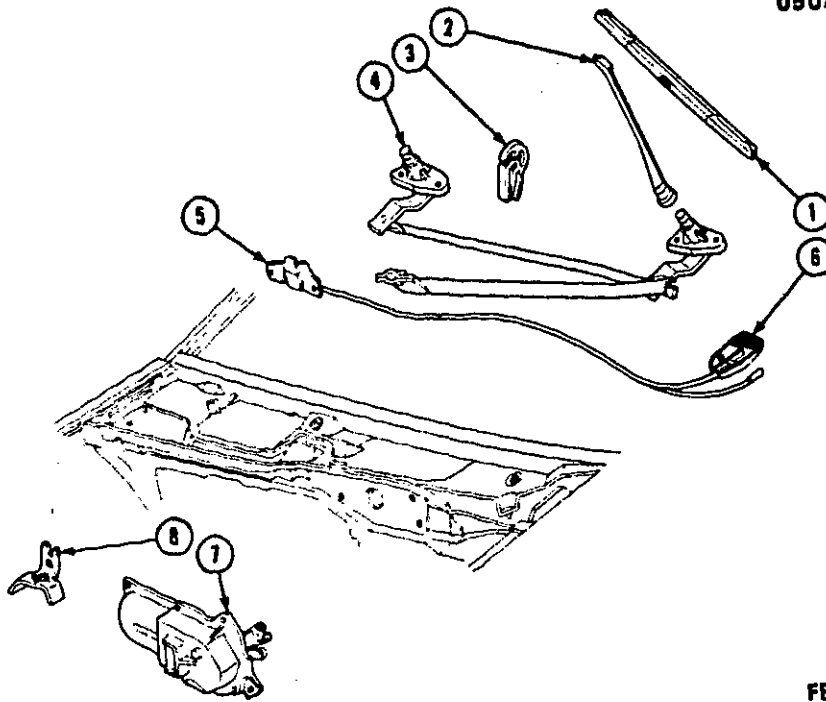

FBS-1864

2P10-008

1984-1987 P WIPER SYSTEM/WINDSHIELD

NOTE FBS-1864

1	E11	10.146	BLADE, WSW (ARTIC 16" H) (1984)	9794295
	E11	10.146	BLADE, WSW (ARTIC 18" H) (1984)	9794303
	E11	10.146	BLADE, WSW (TRICO) (BLACK) (DI CHR) (1984-87)	15595485
	E11	10.146	INSERT, WSW (TRICO)	12399998
2.	E11	10.147	ARM, WSW-RH	20515547
	E11	10.147	ARM, WSW-LH	20302336
3.	E12	10.159	DEFLECTOR, WSW TRANS LINK RR	20451044
4.	E12	10.159	TRANSMISSION, WSW-RH	22039336
	E12	10.159	TRANSMISSION, WSW-LH	22039337
5.	C6	8.080	LOCK, FRT COMPT LID & ACTR (W CABLE)	20389893
6.	C6	8.075	HANDLE, FRT COMPT (BLACK)	20318496
7.	E11	10.150	MOTOR, WSW (1984) (EXC CD4) (1984-85)	22082915
	E11	10.150	MOTOR, WSW (W/CD4) (1985-87)	22182913
8.	N20	11.927	HOUSING, LP FRT COMPT (W LUG COMPT LP)	20432645

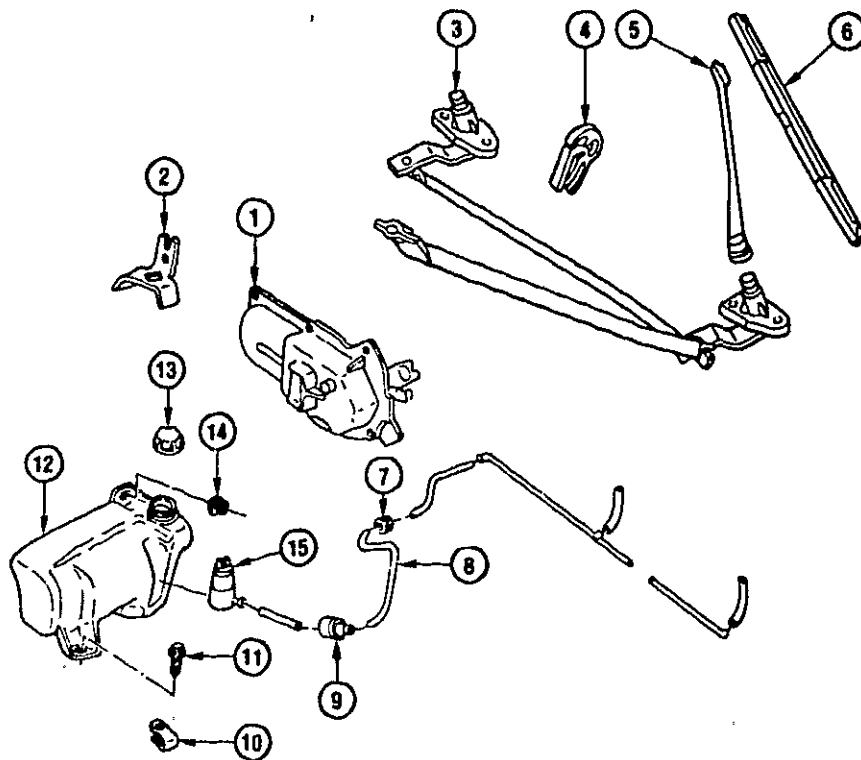

2P10-013

1988 P WIPER SYSTEM/WINDSHIELD

1.	E11	10.150	MOTOR, WSW (EXC CD4)	22062915
	E11	10.150	MOTOR, WSW (W/CD4)	22062913
2.	N20	11.927	HOUSING, LP FRONT COMPT (W/LUG COMPT LP)	20432645
3.	E12	10.159	TRANSMISSION, WSW-RH	22039336
	E12	10.159	TRANSMISSION, WSW-LH	22039337
4.	E12	10.159	DEFLECTOR, WSW TRANS LINK RR	20451044
5.	E11	10.147	ARM, WSW-RH	20515597
	E11	10.147	ARM, WSW-LH	20302338
6.	E11	10.146	BLADE, WSW (TRICOX/BLAKDI-CHR)	15595485
7.	E12	10.154	GROMMET, WSWA HOSE (TO FRT OF DASH)	20344290
		8.962	HOSE, WSW (5/32X25'XCUT FROM BULK)	1359744
8.		10.153	VALVE, WSWA CHK	25523494
9.	E12	8.921	NUT, U SHAPED (M6X1.20X24)1010 STL POR	22538012
10.		8.900	BOLT, HEX W/CON WA (M6X1X25)9 8 PZOR	20351035
11.		10.154	CONTAINER, WSWA SOLV	22062599
12.	E12	10.151	CAP, WSWA SOLV RESV	22062600
13.	E12	8.917	NUT, HEX W/CON WA (M6X1)XTHD OD.19)PEOR	11508277
14.	E12	10.153	PUMP, WSWA	22039339

GM10-086
032686

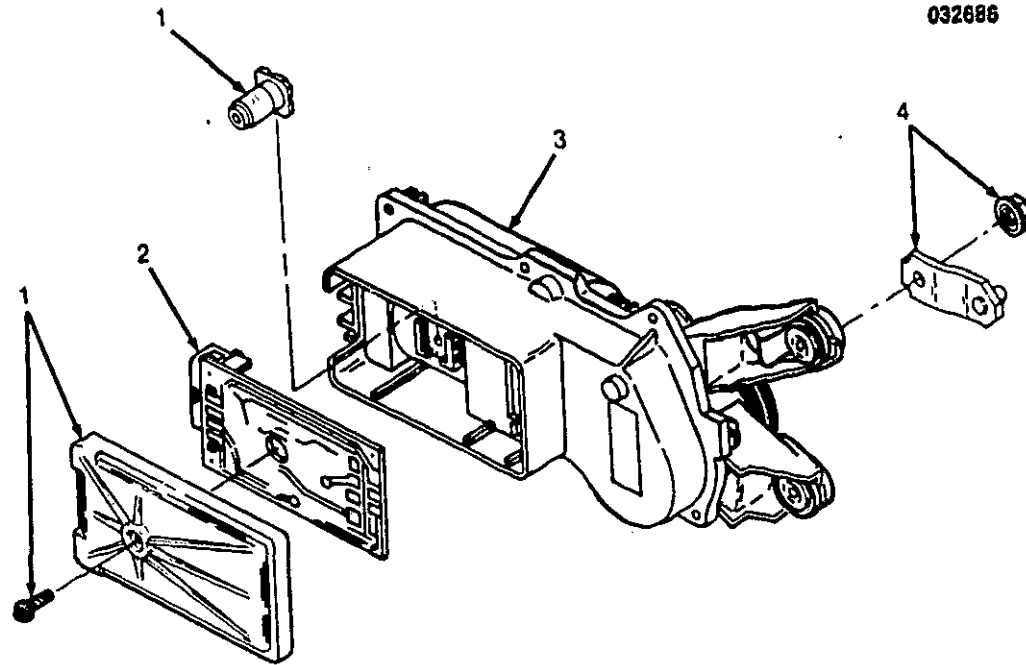

GM10-0861

1984-1988 P WIPER MOTOR/WINDSHIELD (DELCO)(PULSE)

NOTE SEE PARTS CATALOG FOR ADDITIONAL APPLICATION

1.	E12	10.151	COVER KIT, WSW MTR
2.	E11	10.150	BOARD, WSW MTR CIRCUIT
3.	E11	10.150	MOTOR, WSW
4.	E12	10.151	CRANK ARM, WSW MTR

22039315
22102002
22062913
22039338

GM10-068
120286

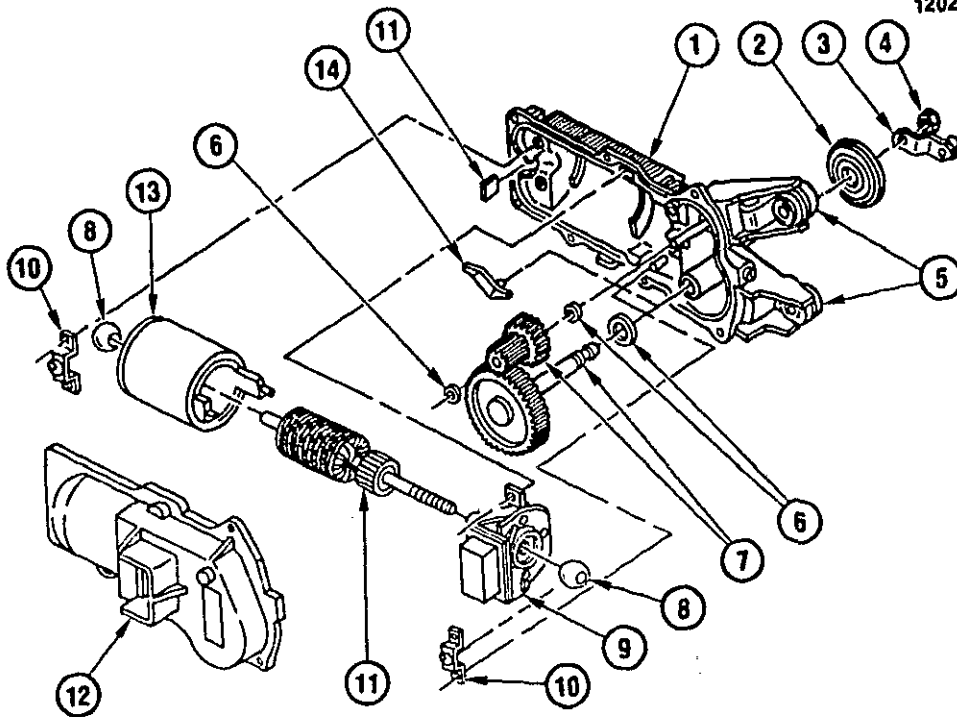

GM10-088

1984-1988 P WIPER MOTOR/WINDSHIELD (DELCO)

NOTE MOTOR, WSW (EXC PULSE) #22062915. GROUP 10 150
NOTE SEE PARTS CATALOG FOR ADDITIONAL APPLICATION

1.	E11	10.150	MOTOR, WSW(*1)	22062915
2.	N.S.	N.S.	SEAL,	22039338
3.	E12	10.151	CRANK ARM, WSW MTR	
4.	N.S.	N.S.	LOCKNUT, CRANK (PART OF #3)	
5.	N.S.	N.S.	GROMMET,	
6.	N.S.	N.S.	WASHER,	22062915
7.	E11	10.150	MOTOR KIT, WIPER(*1)	
8.	N.S.	N.S.	BEARING, ARMATURE (PART OF #11)	22029825
9.	E11	10.150	HOLDER, WSW MTR BRUSH	
10.	N.S.	N.S.	STRAP, BEARING	22030808
11.	E11	10.150	ARMATURE, WSW MTR(*1)	22038937
12.	E12	10.151	COVER KIT, WSW MTR(*1)	22030807
13.	E11	10.150	MAGNET KIT, WSW MTR(*1)	22029824
14.	E11	10.150	ACTUATOR, WSW MTR PARK SW(*1)	

NOTE 1 NEED SCREW PKG #22029895 FOR REASSEMBLY OF MOTOR

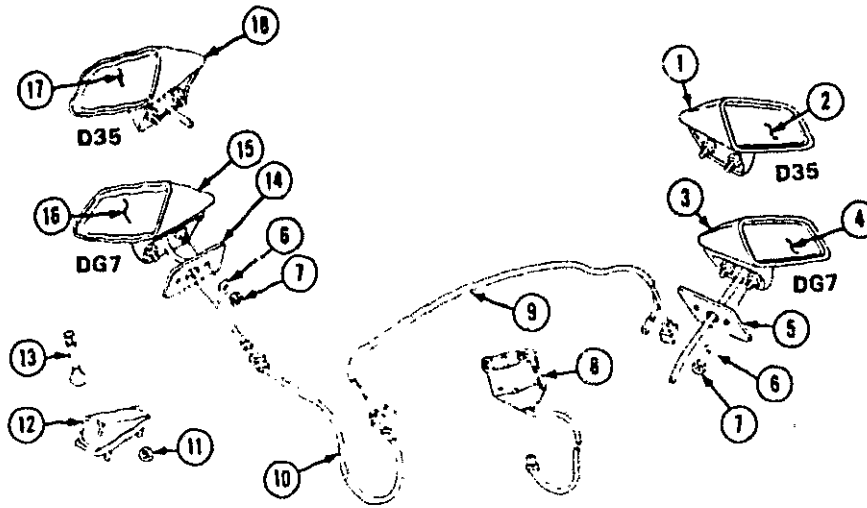

5

1984-1988 P MIRRORS/REAR VIEW-EXTERIOR

NOTE FBS-2629

1.	E13	10.185	MIRROR, O/S MAN-RH (BLACK)	20318520
2.	E13	10.185	GLASS, O/S MIR MAN-RH (CONVEX)(1984-87)	20289778
3.	E13	10.185	MIRROR, O/S ELEC CONT-RH (BLACK)(1984-85)	20318521
	E13	10.185	MIRROR, O/S R/CONT ELEC-RH (BLACK)	10073910
4.	E13	10.185	GLASS, O/S MIR ELEC CONT-RH (W/CASE)(1984)	20442190
	E13	10.185	GLASS, O/S MIR ELEC CONT-RH (W/CASE)(1985-87)	20880142
5.	E13	10.186	GASKET, O/S MIR-RH (BLACK)(W/DG7.D35)	20420122
6.		8.929	WASHER, PLAIN (9/32 ID 5/8 OD)	120392
7.		8.917	NUT, HEX W/TOOTHED CON WA (M6X1X5 05)	11505329
8.	E13	10.185	MOTOR, PWR PACK O/S MIR ELEC (W/DG7 1984-87)	20442185
9.	N26	13.090	HARNESS, ELEC O/S R/CONT MIR (W/DG7 1984-85)	20804191
	N26	13.090	HARNESS, ELEC O/S R/CONT MIR (W/DG7 1986-88)	20828838
10.	N26	13.090	HARNESS, ELEC O/S MIR JPR (W/DG7 1984-85)	20421287
	N26	13.090	HARNESS, ELEC O/S MIR JPR (W/DG7 1986-88)	20528937
11.		8.921	NUT, HEX STMP TYPE R 8-32 PC	145486
12.	E13	10.186	BEZEL, O/S MIR R/CONT-LH (BLACK)	20318522
13.	E13	10.186	KNOB, MIR R/CONT-LH (1984)	20123850
	E13	10.186	KNOB, MIR R/CONT (1985-88)	20328595
14.	E13	10.186	GASKET, O/S MIR-LH (BLACK)(W/DG7.D35)	20420123
15.	E13	10.185	MIRROR, O/S ELEC CONT-LH (BLACK)(1984-85)	20318519
	E13	10.185	MIRROR, O/S R/CONT ELEC-LH (BLACK)(1986-88)	10073911
16.	E13	10.185	GLASS, O/S MIR ELEC CONT-LH (W/CASE)(1984)	20442191
	E13	10.185	GLASS, O/S MIR ELEC CONT-LH (W/CASE)(1985-87)	20880143
17.	E13	10.185	GLASS, O/S MIR R/CONT-LH (1984-87)	20318502
18.	E13	10.185	MIRROR, O/S R/CONT LH (BLACK)	20493539

2P10-001
081088

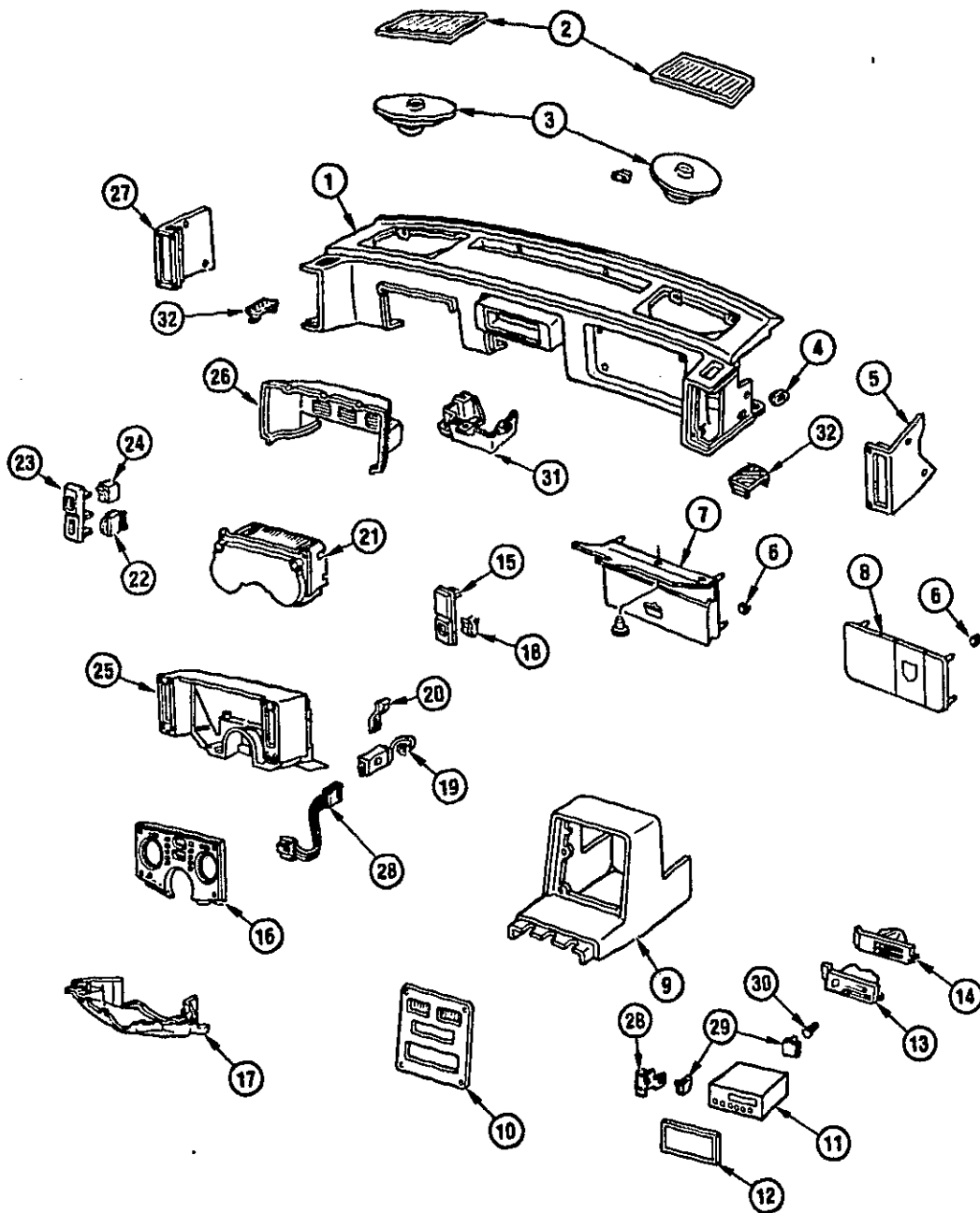

2P10.001

1984-1985 P INSTRUMENT PANEL

1.	E14	10.235	PAD, I P(*2)	10042617
2.	D21	9.650	GRILLE, RDO FRT SPKR-RH	10021295
	D21	9.650	GRILLE, RDO FRT SPKR LH	10021298
3.	D21	9.650	SPEAKER, RDO FRT (W/UW5)	16042082
	D21	9.650	SPEAKER, RDO FRT (W/UP7)	16040920
4.		8.921	NUT, U SPR-THD SIZE 8 NYLON	
5.	E15	10.252	PLATE, I/P TR-RH (GRAPHITE GRAY)(*2)	10021232
6.		8.921	NUT, STAMPED MET (5MM)	
7.	E16	10.260	POCKET, I/P MAP (LT SLATE GRAY)	10021226
	E16	10.260	POCKET, I/P MAP (MED DOESKIN)	10026697
8.	E16	10.260	HOLDER, I/P MAP (GRAPHITE GRAY)	10041761
	E16	10.260	HOLDER, I/P MAP (MED DK DOESKIN)	10029510
9.	E14	10.240	PAD, FRT FLR CNSL TR (FRT)(*2)	10040621
10.	E14	10.240	PLATE, RDO & HVAC TR (SMOKE CHARCOAL GRAY)(1984)	10021258
	E14	10.240	PLATE, RDO & HVAC TR (ROMAN BRONZE)	10026716
	E14	10.240	PLATE, RDO & HVAC TRIM(OXFORD GRAY-13)(1985)	10035306
11.	D21	9.650	RECEIVER, RDO (U63)(1984)(*1)	16033592
	D21	9.650	RECEIVER, RDO (U63)(1985)	
12.	E16	10.256	COVER, RDO OPG HOLE	10023102
13.	D20	9.273	CONTROL, HTR & A/C (1984)	16018322
	D20	9.273	CONTROL, HTR & A/C (1985)	16040702
14.	C13	8.849	CONTROL, HTR (1984)	16018312
	C13	8.849	CONTROL, HTR (1985)	16050062
15.	E15	10.252	PLATE, I/P ACSRY TR-RH(*3)	10021293
16.	E4	9.743	PLATE, I/P CSTR TR (CTR) (SMOKE CHARCOAL GRAY)(1984)	10031181
	E4	9.743	PLATE, I/P CSTR TR (CTR) (ROMAN BRONZE)(1984)	10042776
	E4	9.743	PLATE, I/P CSTR TR-CTR (1985)	10042775
17.	A24	6.760	FILLER, I/P STRG COL OPG	10021287
18.	E5	9.778	SWITCH, RR WDO DEFG (1984)	10026608
	E5	9.778	SWITCH, RR WDO DEFG (1985)	
19.	E12	10.163	MODULE, WSW PULSE CONT (1984)	10036436
	E12	10.163	MODULE, WSW PULSE CONT (1985)	
20.	E11	10.150	CLIP, WSW PULSE CONT MDL (1984)	10030822
	E11	10.150	CLIP, WSW PULSE CONT MDL (1985)	
21.		N.S.	CLUSTER, INST (1984)(*1)	
	D23	9.735	CLUSTER, INST (1985)(*1)	
22.	N10	2.490	CONTROL, I/P LP DMR (1984)	1995262
	N10	2.490	CONTROL, I/P LP DIMMER(GRAY THUMBWHEEL)(1985)	1995296
23.	E15	10.252	PLATE, I/P ACSRY TR-LH	10021294
24.	N10	2.485	SWITCH, HDLP (1984)	1972717
	N10	2.485	SWITCH, HDLP(GRAY KNOB)(1985)	1995294
25.	E4	9.743	HOUSING, I/P CSTR (1984)(*2)	10036749
	E4	9.743	PAD, I/P CSTR (1985)(*2)	
26.	E4	9.743	COVER, INST CSTR RR (1984)(*2)	10030233
	E4	9.743	COVER, INST CSTR RR (1985)	10032986
27.	E15	10.252	PLATE, I/P TR-LH (GRAPHITE GRAY)(*2)	10021233
28.	N10	2.480	WIRE, FUSE BULK ACSRY-W/PULSE WPR	12027627
29.	N14	3.671	BOLT, U NUT & STUD (M5X 8X10)(9 667)	12337892
30.	N14	3.671	RETAINER, RDO(PUSH ON)	10027015
31.	N10	2.483	BRACKET, FUSE BLOCK	10038858
32.	E5	9.780	GRILLE, SI WDO DEFG OTLT-RH	10031033
	E5	9.780	GRILLE, SI WDO DEFG OTLT-LH	10021269

NOTE 1 SEE PARTS CATALOG FOR ADDITIONAL USAGE

NOTE 2 PAINT TO MATCH

NOTE 3 CUT AS REQUIRED

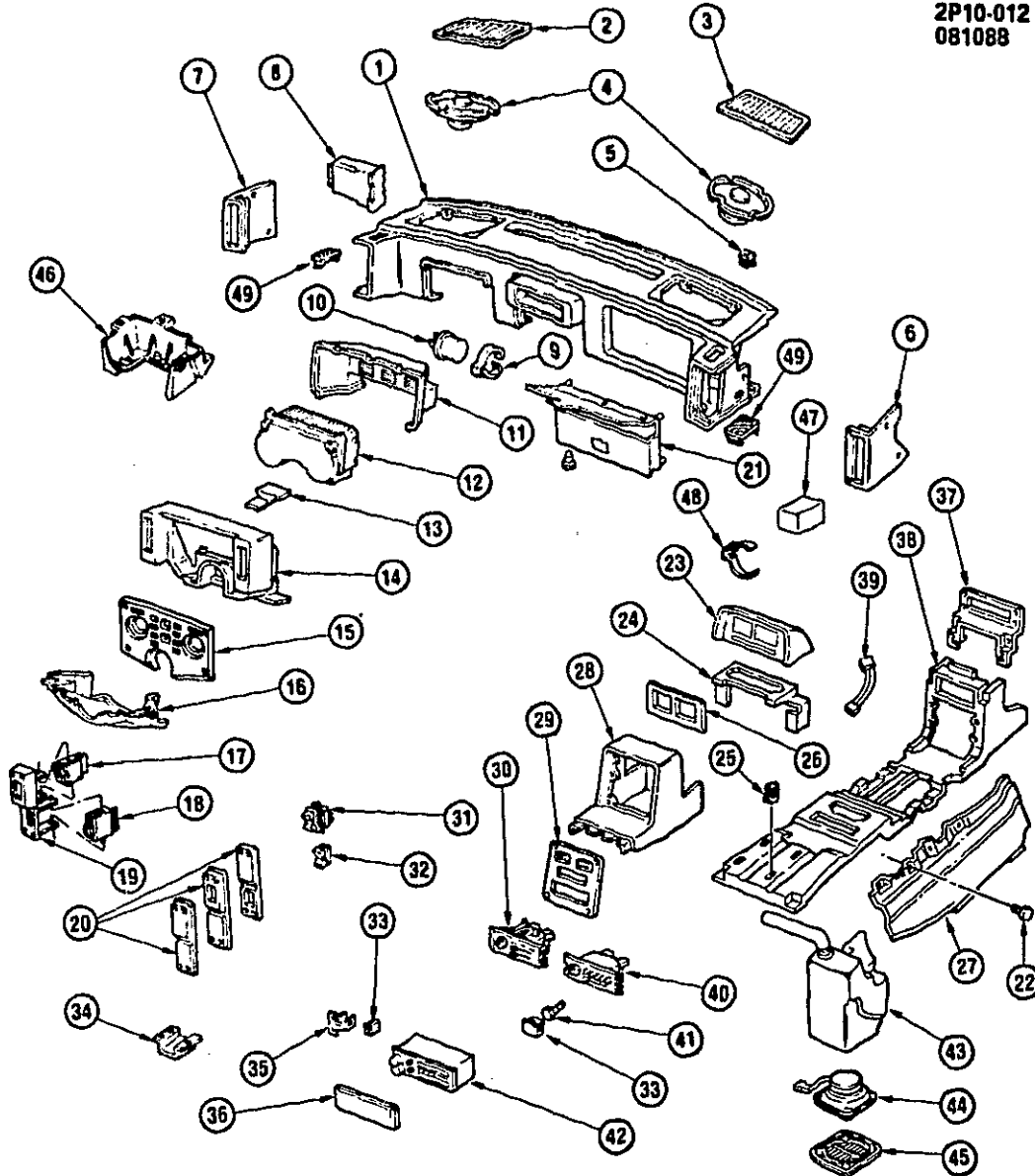

2P10-012

1986-1988 P INSTRUMENT PANEL

1.	E14	10.235	PAD, 1/PI(* 1)	10042617
		8.921	NUT, 1/P (M21X17 5X7 25) TK	1638575
		8.977	SCREW, HWH TAP (M4 2X1 41X35) PC	11502839
2.	D21	9.650	GRILLE, RDO FRT SPKR-LH	10021296
3.	D21	9.650	GRILLE, RDO FRT SPKR-RH	10021295
4.	D21	9.650	SPEAKER, RDO FRT-W/UP7	18040920
		8.977	SCREW, HEX WA HD C/R TAP (M4 2X1 41X20) POR	22536997
5.	D22	9.687	NUT, RDO FRT SPKR	10027915
6.	E15	10.252	PLATE, 1/P TR-RH (GRAPHITE GRAY)(* 1)	10021232
7.	E15	10.252	PLATE, 1/P TR (GRAPHITE GRAY)-LH	10021233
8.	N9	2.195	ALARM, ST BELT & IGN KEY & LPS	10037040
9.	N12	2.892	CLIP, T/SIG LP FLSHR	25534019
10.	N12	2.892	FLASHER, T/SIG LP	10041073
11.	E4	9.743	COVER, INST CSTR RR	10032888

11.	8.977	SCREW, HWH-W INT TORX DRIVE TA (M4 2X1 41X20) PC	22536997
	8.977	SCREW, HEX WA HD C R TAP (M4 2X1 41X20) POR	22536997
12. D23	9.736	CLUSTER, I P	10040808
13. E4	9.744	BRACKET, CSTR HSG	22536997
	8.977	SCREW, HEX WA HD C/R TAP (M4 2X1 41X20) POR	10030749
14. E4	9.743	HOUSING, INST CSTR	12337828
	8.977	BOLT, SEMS HWH (M6 3X1 81X20) PZOR	9431532
	8.921	NUT, U SHAPE (1/4"X1/4) PC	10042775
15. E4	9.743	PLATE, I/P CSTR TR-CTR	14044409
E15	10.252	BOLT, I/P TR PLT (M4 2X1 41X25)(1.683)	10021287
16. A24	6.760	FILLER, I/P STRG COL OPG (GRAY-82)(1)	22536997
	8.977	SCREW, HEX WA HD C/R TAP (M4 2X1 41X20) POR	1995294
17. N10	2.485	SWITCH, HDLP (GRAY KNOB)	1995298
18. N10	2.490	CONTROL, I/P LP DIMMER (GRAY THUMBWHEEL)	10021294
19. E15	10.252	PLATE, I/P ACSRY TR-LH	14048024
E15	10.252	BOLT, I/P ACSRY TR PLT TO CARR UPR	14044409
E15	10.252	BOLT, I/P TR PLT (M4 2X1 41X25)(14 683)	10021293
20. E15	10.252	PLATE, I/P ACSRY TR-RH(12)	14048024
E15	10.252	BOLT, I/P ACSRY TR PLT TO CARR UPR	14044409
E15	10.252	BOLT, I/P TR PLT (M4 2X1 41X25)(14 683)	10037903
21. E16	10.260	HOLDER, I/P MAP (LT SADDLE-62)(PG97 EXC B20)(3)	10037903
E16	10.260	HOLDER, I/P MAP (LT SADDLE-62)(PM37 W/B20)(3)	480534
22. N21	12.801	RETAINER, PNL HOLE (250-THK 03-30)	25089321
23. D23	9.735	CLUSTER, GAGE (VOLT/OIL)	10036124
24. E4	9.755	SUPPORT, GA CSTR	11509374
	8.977	SCREW, HWH TAP (M4 2X1 41X16)	22536997
	8.977	SCREW, HEX WA HD C/R TAP (M4 2X1 41X20) POR	10026904
25. N28	15.300	RETAINER, CARPET TO CNSL CPT SUPT	10036126
26. E14	10.240	PLATE, FLR CNSL ACSRY TR (GRAY-82)(2 8-9)	10041481
E14	10.240	PLATE, FLR CNSL ACSRY TR (LT SADDLE-62)(2 8-9)	14044407
E14	10.240	SCREW, FRT FLR CNSL ACSRY TR PLT	10033815
27. E14	10.240	SUPPORT, F/FLR CNSL CPT LWR-RH	10040821
28. E14	10.240	PAD, CNSL TR (GRAPHITE GRAY-82)	22536997
	8.977	SCREW, HEX WA HD C/R TAP (M4 2X1 41X20) POR	10035308
29. E14	10.240	PLATE, RDO & HVAC TRIM(OXFORD GRAY-13)(1985)	10021270
D20	9.262	OUTLET, CTR AIR	14044409
E15	10.252	BOLT, RDO & HVAC TR PLT TO CNSL CARR (14 683)	16050082
30. C13	8.849	CONTROL, HTR	22536997
	8.977	SCREW, HEX WA HD C/R TAP (M4 2X1 41X20) POR	10038559
31. N21	12.243	SWITCH, LUG COMPT LID REL (ENG COMPT)	11508256
	8.977	SCREW, HWH (M4 2X1 41X13) PC	10038562
32. E5	9.778	SWITCH, RR WDO DEFG	12337892
33. N14	3.671	BOLT, U NUT & STUD (M5X 8X10)(9 667)	1995263
34. N10	2.490	DIMMER, I/P LP	22536997
	8.977	SCREW, HEX WA HD C/R TAP (M4 2X1 41X20) POR	10030589
35. D22	9.667	BRACKET, RDO	22536997
	8.977	SCREW, HEX WA HD C/R TAP (M4 2X1 41X20) POR	10023102
36. E16	10.258	COVER, RDO OPG HOLE	10036128
37. E14	10.240	REINFORCEMENT, FRT FLR CNSL TO I/P	22536997
	8.977	SCREW, HEX WA HD C/R TAP (M4 2X1 41X20) POR	10040789
38. E14	10.240	SUPPORT, FRT FLR CNSL	11505169
	8.977	SCREW, HWH TAP (M4 2X1 41X13) POR	52361724
	8.921	NUT, U SHAPE (M4 2X1 41) ZOR	12046505
39. N10	2.480	HARNES, GAGE CSTR WRG	16040702
40. D20	9.273	CONTROL, HTR & A/C	22536997
	8.977	SCREW, HEX WA HD C/R TAP (M4 2X1 41X20) POR	10027015
41. D22	9.667	RETAINER, RDO (PUSH-ON)	16048312
42. D21	9.650	RECEIVER, RDO (UM7)	16029862
43. D21	9.650	HOUSING, LOW FREQ AUDIO AMPF	11505169
	8.977	SCREW, HWH TAP (M4 2X1 41X13) POR	20899808
	10.695	FASTENER, DR INR PNL W/STR	16042082
44. D21	9.650	SPEAKER, RDO FRT	
45. D21	9.650	GRILLE, RDO HSG SPKR	
	8.977	BOLT, HWH-DRILLER (M4 2X1 41X30) PZOR	11508602
46. N10	2.483	BRACKET, FUSE BLOCK	10038868
47. N21	12.243	RELAY, L/COMPT LID REL (2 815)	25523703
48. N21	12.184	CLIP, L/COMPT LID REL RLY (2 892)	25534019
49. E5	9.780	GRILLE, SI WDO DEFG OTLT-RH	10031033
E5	9.780	GRILLE, SI WDO DEFG OTLT-LH	10021269

NOTE 1 PAINT TO MATCH.

NOTE 2 CUT HOLES AS REQUIRED

NOTE 3 SEE PARTS CATALOG GROUP FOR ADDITIONAL USAGE

2P10-002
052984

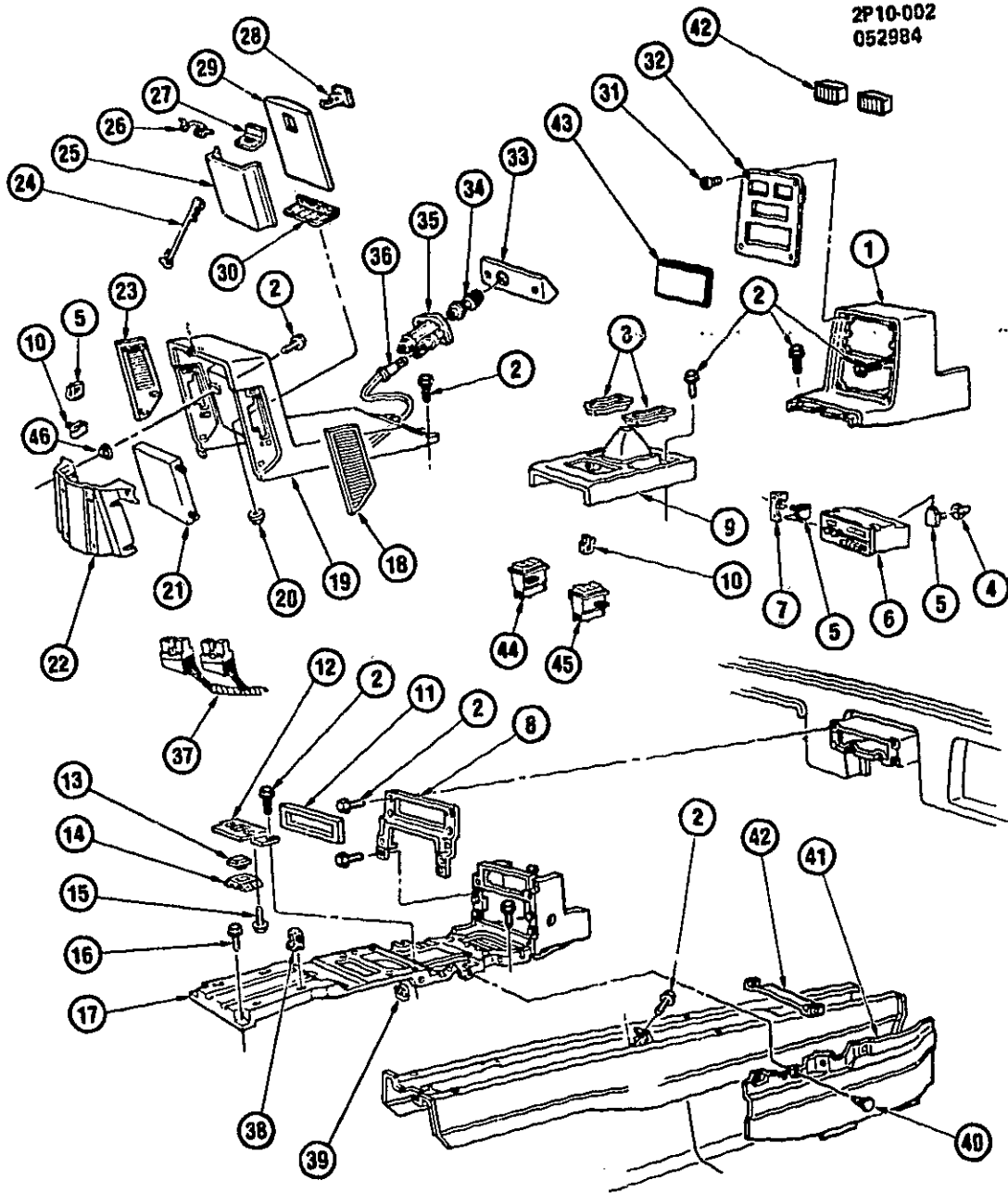

2P10-002

1984-1985 P CONSOLE/FLOOR

1.	E14	10.240	PAD, CNSL TR-FRT (GRAPHITE GRAY)(*) 1)	10040621
2.		8.977	SCREW, HEX TAP (M4 2 X 1 41 X 20)	
3.	E15	10.242	TRAY, ASH	10031793
	E15	10.242	DOOR, CNSL ASH-RH	10027210
	E15	10.242	DOOR, CNSL ASH-LH	10027209
	E15	10.242	SPRING, ASH TRAY DR-LH	10038438
	E15	10.242	SPRING, ASH TRAY DR-RH	10026961
4.	D22	9.667	RETAINER, RDO PUSH-ON (3 671)	10027015
5.	N14	3.671	BOLT, U NUT & STUD (M5X 3X10X9 667)	12337892
6.	D21	9.650	RECEIVER, RDO (1984)	16073602
	D21	9.650	RECEIVER, RDO (1985)	
7.	D22	9.667	BRACKET, RDO	10030589
8.	E14	10.240	REINFORCEMENT, CNSL TO I/P	10036128
9.	E14	10.240	PLATE, A/T CNSL SHFT OPG (BRUSHED PEWTER-13I)(1984)	10026852
	E14	10.240	PLATE, A/T CNSL SHFT OPG (ROMAN BRONZE-64I)(1984-85)	10026709
	E14	10.240	PLATE, M/T CNSL SHFT OPG (BRUSHED PEWTER-13I)(1984)	10026851
	E14	10.240	PLATE, M/T CNSL SHFT OPG (ROMAN BRONZE-64I)(1984)	10026710
	E14	10.240	PLATE, M17 CNSL SHFT OPG (OXFORD GRAY-13I)(1985)	10035837
	E14	10.240	PLATE, M17 CNSL SHFT OPG (MED DOESKIN-64I)(1985)	10036275
	E14	10.240	PLATE, MT2 CNSL SHFT OPG (MED DOESKIN-64I)(1985)	10033957
	E14	10.240	PLATE, MT2 CNSL SHFT OPG (OXFORD GRAY-13I)(1985)	10033958
	E14	10.240	PLATE, A/T CNSL SHFT OPG (OXFORD GRAY-13I)(1985)	10035309
	N14	4.015	BOOT, M/T CONT LVR	10021280
	N14	4.015	BOOT, A/T CONT LVR	14107317
10.	N14	3.671	CLIP, I/P TRIM PLT (10 252)	25510099
11.		N.S.	SEAL, TRIM PLT TO CARRIER	
12.	E14	10.240	PLATE, CNSL ACSRY SW MTG (1984)	10035970
	E14	10.240	PLATE, ACSRY SW MTG (EXC A31, DG7)	10035970
	E14	10.240	PLATE, ACSRY SW MT-W/A31 EXC DG7 (1985)	10035967
	E14	10.240	PLATE, ACSRY SW MT-W/DG7 EXC A31 (1985)	10035988
	E14	10.240	PLATE, ACSRY SW MT-W/DG7, A31 (1985)	10035989
13.	E13	10.188	SWITCH, SPORT MIRROR	20804190
14.		N.S.	ESCUTCHEON, SWITCH	
15.		8.977	SCREW, PAN HD C/R TAP (M4 2 X 2 25 X 13)	
16.		8.977	SCREW, HWH TAP (M6 3 X 1 B1 X 25)	
17.	E14	10.240	SUPPORT, CNSL	10040789
18.	E14	10.240	GRILLE, ECM VEN (RH)(*) 1)	10039985
19.	E15	10.252	PAD, CNSL TRIM-RR(*) 1)	10039845
	E14	10.240	PLUG, FRT FLR RR CNSL COMPT(*) 1)	10039847
20.		8.915	NUT, HWH (M5 X 0 8)	
21.	N13	3.670	CONTROLLER, ECM (REMFDX)(1984)	12261556
	N13	3.670	CONTROLLER, ECM (REMFDX)(1985)	
	N13	3.670	CALIBRATOR, PROM (CODE 6742 CLM)(1984)	16089211
	N13	3.670	CALIBRATOR, PROM (CODE 0000 CLM)(1985)	
22.	N14	3.671	BRACKET, ECM	10021279
23.	E14	10.240	GRILLE, CONT MDL VENT-LH(*) 1)	10039986
24.	E16	10.262	STRAP, CNSL DR RET	10026502
25.	E16	10.260	COMPARTMENT, CNSL(*) 1)	10039841
26.	E16	10.268	SPRING, CNSL DR LAT	10026903
27.	E16	10.268	STRIKER, CNSL DR	10026886
28.	E16	10.268	LATCH, CNSL DR	10026678
29.	E16	10.261	DOOR, CNSL (SLATE GRAY)(*) 1)	10039843
30.	E16	10.262	HINGE, CNSL DR	10026879
31.	E15	10.252	BOLT, TRIM PLT TO CNSL CARRIER (14 683)	14044409
32.	E14	10.240	PLATE, RDO (SMOKE CHARCOAL BRUSH)(1984)	10021258
	E14	10.240	PLATE, RDO (ROMAN BRONZE)	10026716
	E14	10.240	PLATE, RDO & HVAC TRIM(OXFORD GRAY-13I)(1985)	10035306
33.	D22	9.709	PLATE, CNSL TRIM	10032354
34.	D22	9.709	LIGHTER, CIG W/KNOB (1984)	10026354
	D22	9.709	LIGHTER, CIG W/KNOB (1985)	
35.	D22	9.709	HOUSING, C/LTR (1984)	10028485
	D22	9.709	HOUSING, C/LTR (1985)	
	D22	9.709	RETAINER, C/LTR SHELL	1608828
	D22	9.709	RETAINER, C/LTR HSG	10021298
36.		8.991	BULB, C/LTR	
37.	N10	2.480	HARNES, ECM	12027633
38.	N28	15.300	RETAINER, CNSL CARPET	10028904
39.	N14	3.671	CLIP, I/P TRIM PLT (10 252)	25510099
40.	N21	12.801	RETAINER, CNSL	480534
41.	E14	10.240	SUPPORT, CNSL CARPET-RH	10023104
	E14	10.240	SUPPORT, CNSL CARPET-LH (1984)	10023105
	E14	10.240	SUPPORT, CNSL CPT LWR-LH (1985)	10033818
42.	D20	9.262	OUTLET, CTR AIR	10021270

43.	E18	10.256	COVER, RDO OPG HOLE
44.	E20	10.777	SWITCH, WDO LH (1984)
45.	E20	10.777	SWITCH, WDO RH (1984)
46.	E14	10.240	GROMMET, RR PAD TO ECM BRKT (8 016)

10023102
10026610
10026611
1264963

NOTE 1 PAINT TO MATCH

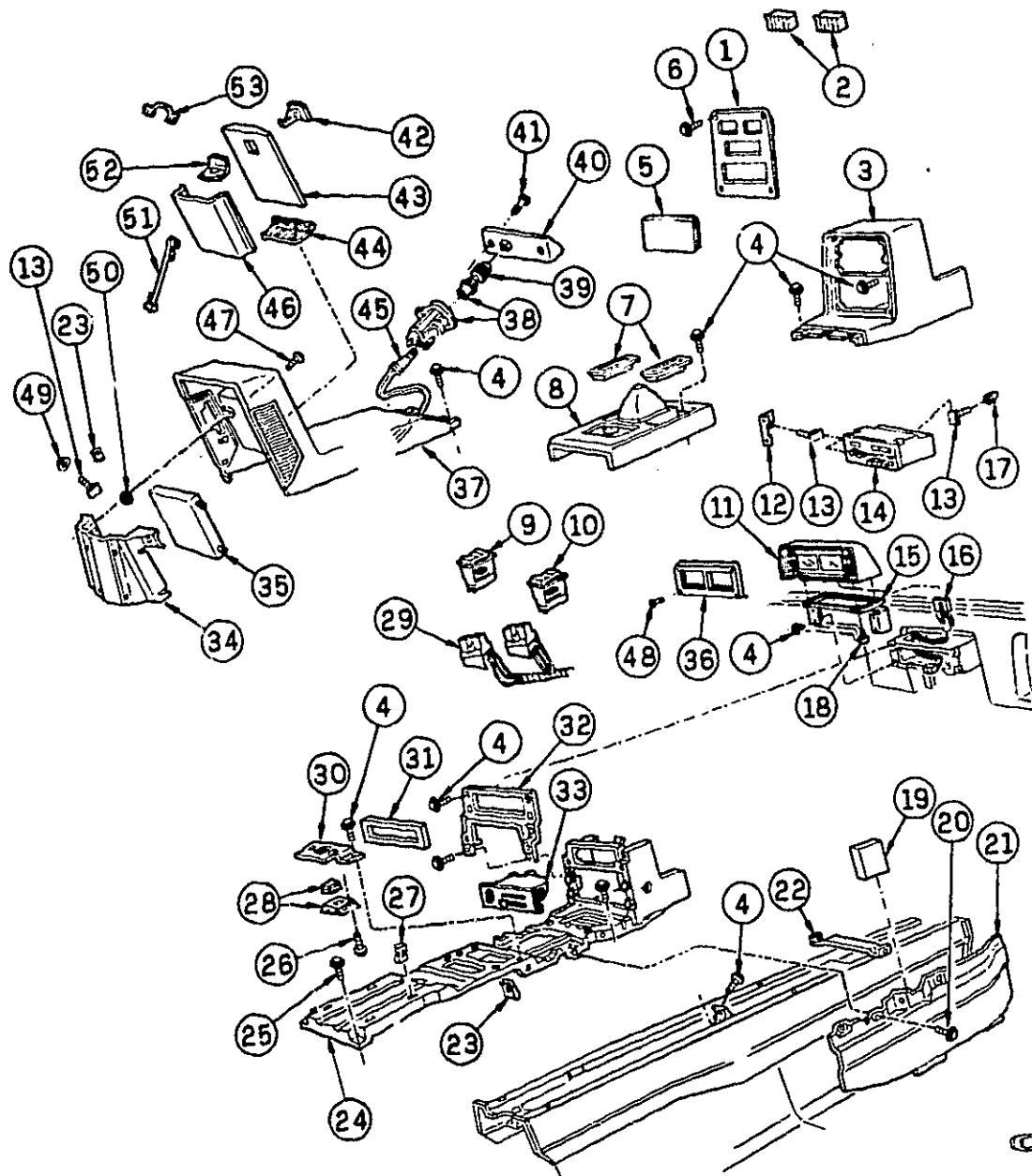

1986-1987 P CONSOLE/FLOOR

1.	E14	10.240	PLATE, RDO & HVAC TRIM(OXFORD GRAY-13)(1985)	10035306
2.	D20	9.262	OUTLET, CTR AIR	10021270
	N14	3.671	CLIP, VENT GR L (10252)	25610099
3.	E14	10.240	PAD, CNSL TR (GRAPHITE GRAY 82)(2 5R)	10040621
4.		8.977	SCREW, HEX WA HD C/R TAP (M4 2X1 41X20) POR	22536997
5.	E16	10.266	COVER, RDO OPG HOLE	10023102
6.	E15	10.252	BOLT, RDO & HVAC TR PLT/CNSL CARR (14 683)	14044409
7.	E15	10.242	TRAY, ASH	10031793
8.	E14	10.240	PLATE, SHFT OPG TR-W/MT2	10033956
	E14	10.240	PLATE, SHFT OPG TR-W/MG2.MT2	10039852
	E14	10.240	PLATE, SHFT OPG TR (MD9)(OXFORD GRAY)	10035309
	E14	10.240	PLATE, SHFT OPG TR (MD9)(DK SADDLE-62)	10039853
9.	E20	10.777	SWITCH, SI WDO-LH (GRAY RKR KNOB)(W/ELEC WDO)	10036561
		8.977	SCREW, HWH (M4 2X1 41X13 POR HILO)	11508256
10.	E20	10.777	SWITCH, SI WDO-RH (GRAY RKR KNOB)(W/ELEC WDO)	10036560
		8.977	SCREW, HWH (M4 2X1 41X13 POR HILO)	11508256
11.	D23	9.735	CLUSTER, W/HOUSING-GA (2 8-9)	25089321
12.	D22	9.667	BRACKET, RDO-W/UO6 U66 UP7	10030589
13.	N14	3.671	BOLT, U NUT & STUD (M5X 8X10)(9 667)	12337892
14.	D21	9.650	RECEIVER, RDO-W/STEREO (UM7)	18046312
15.	E4	9.755	SUPPORT, GA CSTR (2 8-9)	10036124
16.	N10	2.480	HARNESS, GAGE CSTR WRG (2 8-9)	12046505
17.	D22	9.667	RETAINER, RDO-PUSH ON (3 671)	10027016
18.		8.977	SCREW, HWH TAP (M4 2X1 41X16 TYPE AB)	11509374
19.	D21	9.651	BOOSTER, LOW FREQ AUDIO(BASE TONES)(W/UO6)	18081972
20.	N21	12.801	RETAINER, PNL HOLE (1/4" THK 03-30)	480534
21.	E14	10.240	SUPPORT, CNSL CPT LWR-RH	10033916
	E14	10.240	SUPPORT, CNSL CPT LWR-LH	10033816
22.	E14	10.240	BRACKET, CNSL SUPT FRT	10040791
23.		8.921	NUT, U SHAPE (M4 2 X 1 41 X 065)(ZOR)	52351724
24.	E14	10.240	SUPPORT, FRT FLR CNSL	10040789
25.		8.977	SCREW, HWH TAP (M4 2X1 41X13 AB-POR)	11505169
26.		8.977	SCREW, HWH (M4 2X1 41X13 POR HILO)	11508256
27.	N28	15.300	RETAINER, CNSL CPT SUPT (CARPET TO SUPT)	10026904
28.	E13	10.186	SWITCH, ELEC TOUCH CONT O/S REM CONT MIR	20804190
29.	N26	13.090	HARNESS, WRG ELEC O/S R/CON MIR CR CAR	
30.	E14	10.240	PLATE, CNSL ACSRY SW MT	10035968
31.	D20	9.262	SEAL, FOAM (46 5"X 36"X 5")(1)	363139
32.	E14	10.240	REINFORCEMENT, CNSL TO I/P	10036128
33.	C13	8.849	CONTROL, HTR	18050082
	D20	9.273	CONTROL, HTR & A/C	18040702
34.	N14	3.671	BRACKET, ELEK FUEL CONT MDL TO RR BLKH	10021279
35.	N13	3.670	CONTROLLER, ECM (REMF)(1986 2 8-9 W/M T FED.CALIF)	1227151
	N13	3.670	CONTROLLER, ECM (REMF)(2 8-9 W/A T FED.CALIF)	1227170
36.	E14	10.240	PLATE, FLR CNSL ACSRY TR (GRAY-82)	10036125
	E14	10.240	PLATE, CNSL ACSRY TR (LT SADDLE-62)	10041491
37.	E15	10.252	PAD, FRT FLR CNSL TR RR(PARTIAL)(LT SLATE GRAY)(2)	10039845
	E14	10.240	PAD, SOUND ABS RR CNSL	10028022
	E14	10.240	PLUG, RR CNSL COMPT	10039847
38.	D22	9.709	HOUSING, C/LTR	10042611
		8.977	SCREW, RD LG WA HD C/R TAP (M4 2X1 41X20 POR)	11504625
39.	D22	9.709	LIGHTER, W/KNOB & SHIELD CIG	22548286
40.	D22	9.709	PLATE, CNSL TR (C/LTR)	10032354
41.	E15	10.252	BOLT, TR PLT/CNSL CARR (14 683)	14044409
42.	E16	10.268	LATCH, RR CNSL DR	10025678
43.	E16	10.261	DOOR, RR CNSL (SLATE GRAY-13)(2)	10039843
44.	E16	10.262	HINGE, RR CNSL DR	10025679
45.	N10	2.480	HARNESS, I/P	12051892
46.	E16	10.260	COMPARTMENT, RR CNSL	10039841
47.		8.977	SCREW, HWH TAP (M4 2X1 41X25 ZC)	11504591
48.	E14	10.240	SCREW, CNSL ACSRY TR PLT	14044407
49.		8.917	NUT, HEX FLG (M5X0 8 ORD 9 ZC)	11502702
50.	E14	10.240	GROMMET, CNSL TR PAD (CR PAD TO ECM BRKT)	1284963
51.	E16	10.262	STRAP, RR CNSL DR RET	10026502
52.	E16	10.268	STRIKER, RR CNSL DR	10025686
53.	E16	10.268	SPRING, RR CNSL DR LAT	10026903

NOTE 1 CUT TO SIZE
NOTE 2 PAINT TO MATCH

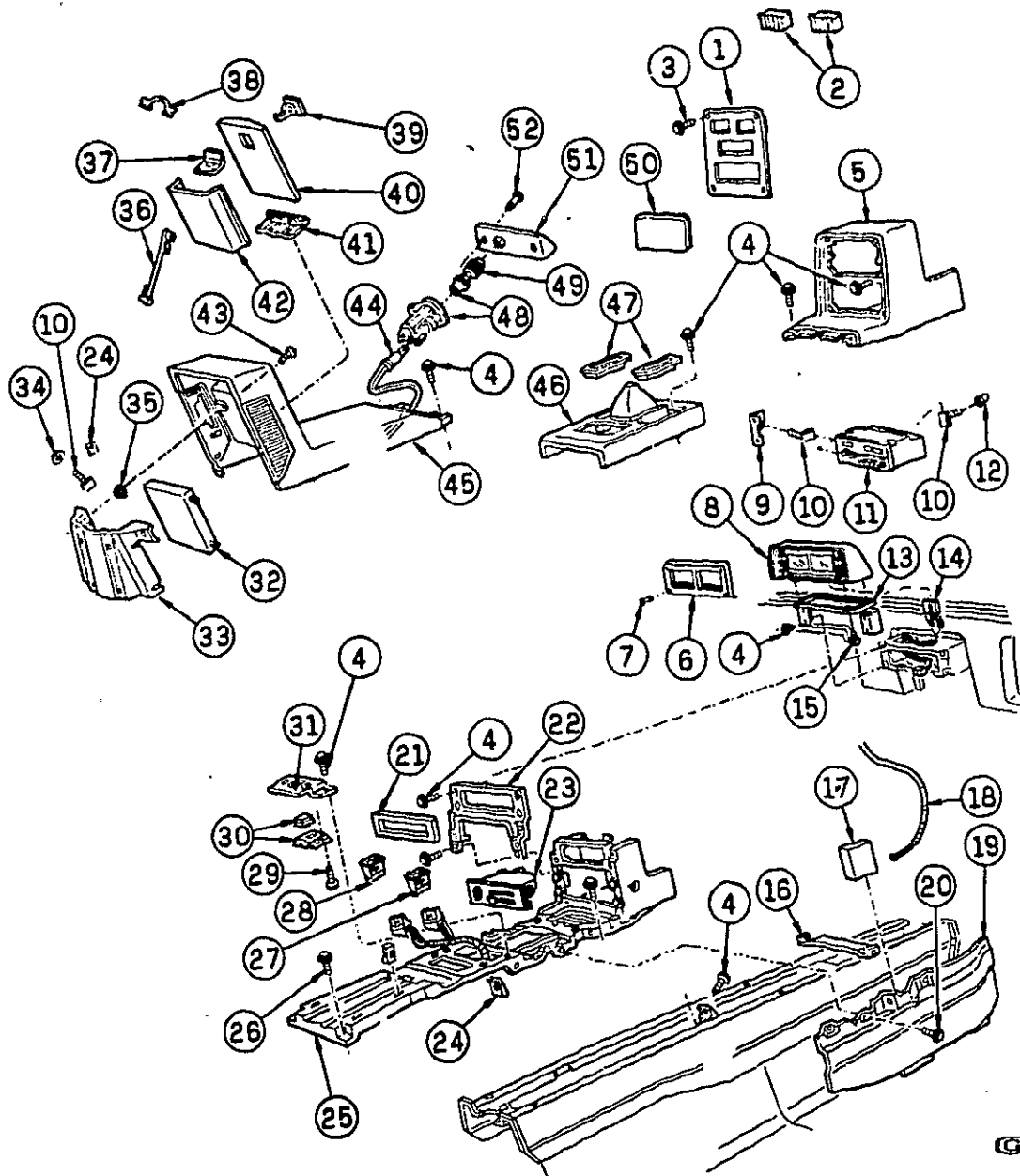

1988 P CONSOLE/FLOOR

1.	E14	10.240	PLATE, CNSL TR (RDO & HVAC)	10095177
2.	D20	9.262	OUTLET, CTR AIR	10021270
	E14	10.240	CLIP, FRT FLR CNSL TR PLT (10 252)	25510099
3.	E15	10.252	BOLT, RDO & HVAC TR PLT/CNSL CARR (14 683)	14044409
4.		8.977	SCREW, HWH (M4 2X1 41X20)X9 2OD 13 8 THD)ZN PHOS	22536987
5.	E14	10.240	PAD, F/FLR CNSL TR (GRAPHITE GRA-82)X2 5RX" 1)	10040821
6.	E14	10.240	PLATE, FRT FLR CNSL ACSRY TR (2 8-9)	10082805
7.	E14	10.240	SCREW, FRT FLR CNSL ACSRY TR PLT (2 8-9)	14044407
8.	D23	9.735	CLUSTER, W/HOUSING GA (2 8-9)	25089321
9.	D22	9.667	BRACKET, RDO (W/UQ6.U66.UP7)	10030589
10.	N14	3.671	BOLT, U NUT & STUD (M5X 8X10)X9 667)	12337892
11.	D21	9.650	RECEIVER, RDO (W/UM7)	16048312
12.	D22	9.667	RETAINER, RDO (PUSH-ON)X3 671)	10027015
13.	E4	9.755	SUPPORT, GA CSTR (2 8-9)	10038124
14.	N10	2.480	HARNES, GA CSTR WRG (2 8-9)	12046505
15.		8.977	SCREW, HEX TAP (M4 2X1 41X16)NIC ORG	11508374
16.	E14	10.240	BRACKET, FRT FLR CNSL SUPT FRT	10040791
17.	D21	9.651	BOOSTER, LOW FREQ AUDIO (BASE TONES)W/UQ6)	16081972
18.	D22	9.656	HARNES, LOW FREQ AUDIO AMPF WRG (W/UQ6)	12046518
19.	E14	10.240	SUPPORT, F/FLR CNSL CPT LWR-RH	10033815
	E14	10.240	SUPPORT, FRT FLR CNSL CPT LWR-LH	10033816
20.	N21	12.801	RETAINER, PNL HOLE (1/4" THK 03- 30)	480534
21.	D20	9.262	SEAL, FOAM (46 5"X 36"X 5"X"2)	383139
22.	E14	10.240	REINFORCEMENT, FRT FLR CNSL TO I/P	10036128
23.	C13	8.849	CONTROL, HTR (W/HTR)C41)	16050082
	D20	9.273	CONTROL, HTR & A C	16040702
24.		8.921	NUT, U SHAPE (M4 2X1 41X 065)ZOR	52351724
25.	E14	10.240	SUPPORT, FRT FLR CNSL	10040789
26.		8.977	SCREW, HWH TAP (M4 2X1 41X13 TYPE AB)POR	11505189
27.	E20	10.777	SWITCH, SI WDO-RH (GRA RKR KNOB)W/ELEC WDO)(A3 1)	10036560
		8.977	SCREW, HWH (M4 2X1 41X13)POR HILO	11508256
28.	E20	10.777	SWITCH, SI WDO-LH (GRA RKR KNOB)W/ELEC WDO)(A3 1)	10036561
29.		8.977	SCREW, HWH (M4 2X1 41X13)POR HILO	11508256
30.	E13	10.186	SWITCH, ELEC TOUCH CONT O/S REM CONT MIR	20804190
31.	E14	10.240	PLATE, FRT FLR CNSL ACSRY SW MT	10035988
32.	N13	3.670	CONTROLLER, ECM (REMAN)X2 8-9)W/FED.CALIF	12271170
33.	N14	3.671	BRACKET, ELEK FUEL CONT MDL TO RR BLKH	10021279
34.		8.917	NUT, HEX FLG (M5X0 8) ORD 9 ZC	11502702
35.	E14	10.240	GROMMET, CNSL TR PAD (RR PAD TO ECM BRKT)	1264983
36.	E16	10.262	STRAP, FRT FLR RR CNSL DR RET	10028502
37.	E16	10.268	STRIKER, FRT FLR RR CNSL DR	10025688
38.	E16	10.268	SPRING, FRT FLR RR CNSL DR LAT	10028903
39.	E16	10.268	LATCH, RR CNSL DR	10025678
40.	E16	10.261	DOOR, RR CNSL	10039843
41.	E16	10.262	HINGE, RR CNSL DR	10025679
42.	E16	10.260	COMPARTMENT, RR CNSL	10039841
43.		8.977	SCREW, HWH TAP (M4 2X1 41X25 (10 783)	1640810
44.	N10	2.480	HARNES, I/P WRG	12051892
45.	E15	10.252	PAD, CNSL TR RR (PARTIAL)	10039845
	E14	10.240	PAD, SOUND ABS RR CNSL	10028022
	E14	10.240	PLUG, RR CNSL COMPT	10039847
46.	E14	10.240	PLATE, CNSL TRANS SHIFT (DK SIENN)W/M T	10076176
	E14	10.240	PLATE, CNSL TRANS SHFT OPG TR (DK GRA)W/MG2.MT2)	10082806
47.	E15	10.242	TRAY, ASH	10031793
48.	D22	9.709	HOUSING, C/LTR	10042811
		8.977	SCREW, RD LG WA HD C/R TAP (M4 2X1 41X2)POR	11504825
49.	D22	9.709	LIGHTER, W/KNOB & SHIELD CIG	22548268
50.	E16	10.256	COVER, RDO OPG HOLE	10023102
51.	D22	9.709	PLATE, FRT FLR RR CNSL TR (C/LTR)	10032354
52.	E16	10.252	BOLT, RDO & HVAC TR PLT/CNSL CARR (14 683)	14044409

NOTE 1 PAINT TO MATCH

NOTE 2 CUT TO SIZE

2P10-004
052286

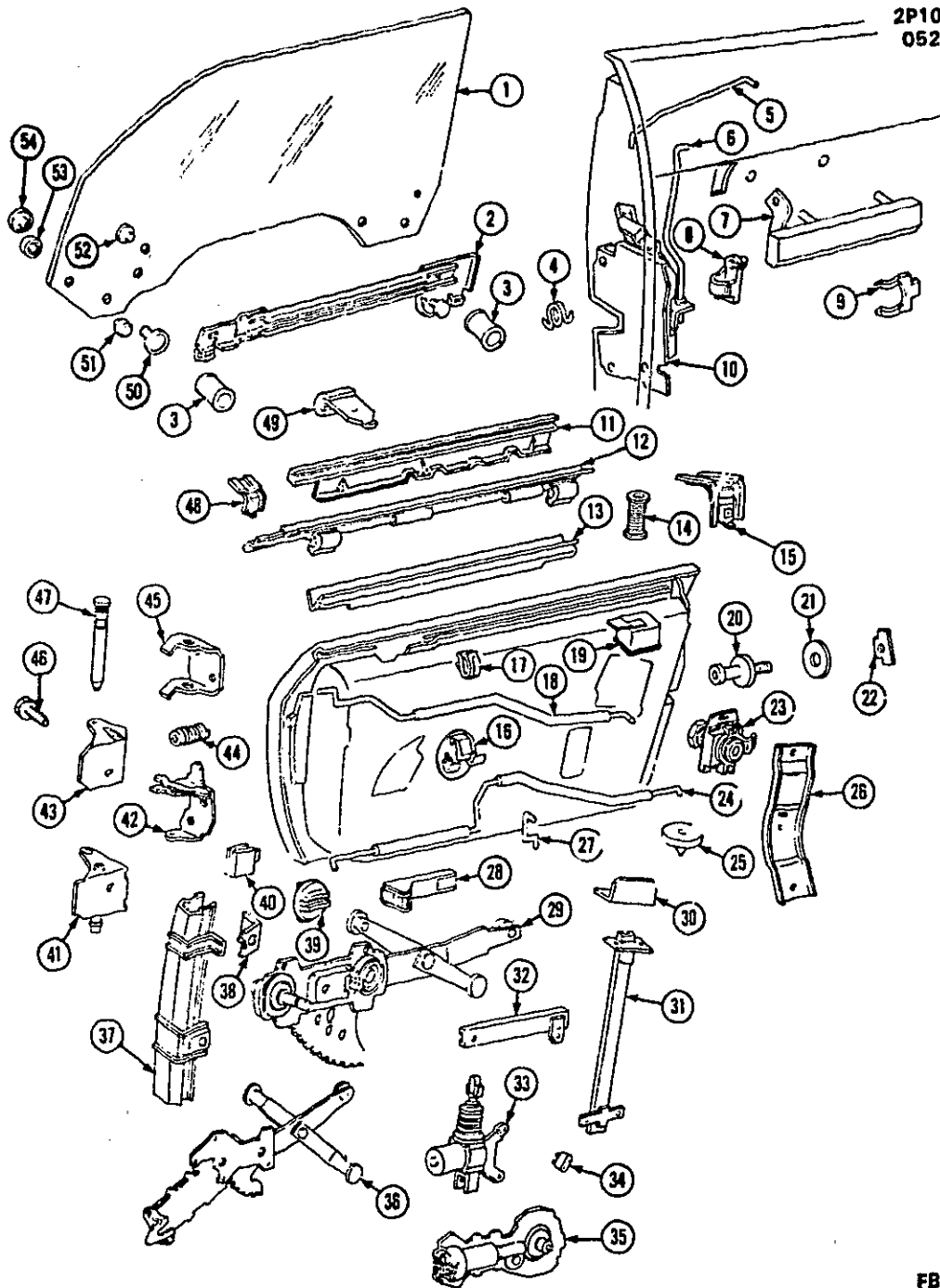

FBS-1865

2P10-004

1984-1988 F DOOR HARDWARE/FRONT

NOTE FBS-1865

1.	E19	10.681	GLASS, WDO-RH (CLEAR)(P37)	20439138
	E19	10.681	GLASS, WDO-LH (CLEAR)(P37)	20439139
	E19	10.681	GLASS, WDO-RH (TINTED)	20326124
	E19	10.681	GLASS, WDO-LH (TINTED)	20326125
2.	E21	10.792	CAM, WDO GLS REG-RH	20364928
	E21	10.792	CAM, WDO GLS REG-LH	20364929
3.	E20	10.716	STOP, WDO GLS RR ON GLS	20085501
4.	E17	10.474	SPRING, LK OVER CTR-RH	20047022
	E17	10.474	SPRING, LK OVER CTR-LH	20047023
5.	E18	10.563	ROD, LK CYL TO LK-RH	20318484
	E18	10.563	ROD, LK CYL TO LK-LH	20318485
6.	E18	10.563	ROD, O/S HDL TO LK-RH	20318482
	E18	10.563	ROD, O/S HDL TO LK-LH	20318483
7.	E18	10.527	HANDLE, O/S LIFT BAR-RH (COMPLETE)	20833580
	E18	10.527	HANDLE, O/S LIFT BAR-LH (COMPLETE)	20833581
8.	E18	10.527	CLIP, LIFT BAR HDL O/S (10.565)	20158344
9.	E18	10.551	RETAINER, LK CYL	20318476
10.	E17	10.470	LOCK, F/D-RH(*1)	16608172
	E17	10.470	LOCK, F/D-LH(*1)	16608173
11.	N28	14.683	RETAINER, TR AT BELT-RH (1984-86)	20352808
	N28	14.683	RETAINER, TR AT BELT-LH (1984-85)	20352807
	N28	14.683	RETAINER, TR AT BELT-RH (1986-88)	20630876
	N28	14.683	RETAINER, TR AT BELT-LH (1986-88)	20830877
12.	E20	10.710	SEALING STRIP, WDO OTR AT BELT-RH (1984)(*2)	20320532
	E20	10.710	SEALING STRIP, WDO OTR AT BELT-LH (1984)(*2)	20320533
	E20	10.710	SEALING STRIP, WDO OTR AT BELT-RH (BLACK)(1984-88)(*3)	20808220
	E20	10.710	SEALING STRIP, WDO OTR AT BELT-LH (BLACK)(1984-88)(*3)	20808221
13.	E20	10.710	SEALING STRIP, WDO INR AT BELT-RH	20320534
	E20	10.710	SEALING STRIP, WDO INR AT BELT-LH	20320535
14.	E17	10.474	SPRING, LK PUSH BUTN RTN	20088089
15.	E20	10.716	STOP, WDO GLS ON INR PNL	20175950
16.	E19	10.565	CLIP, 1/S LK ROD TO INR PNL	20474324
17.	E19	10.565	CLIP, 1/S LK ROD TO LK	20474900
18.	E18	10.563	ROD, LK R/CONT TO LK-RH	20318486
	E18	10.563	ROD, LK R/CONT TO LK-LH	20318487
19.	N27	13.095	RELAY, ELEC DR LK (W/AU3)	20306058
20.	E19	10.689	STRIKER, LK	20484563
21.		8.929	WASHER, FLAT (11X40X3)(PHOS)	11500367
22.	E19	10.671	PLATE, LK STKR ANC	20277001
23.	N22	12.895	BLOCK, DR OTR PNL ATCH	20505072
24.	E18	10.563	ROD, 1/S LK TO LK-RH	20807584
	E18	10.563	ROD, 1/S LK TO LK-LH	20807585
25.	E20	10.716	BUMPER, WDO REG STOP	20289755
26.	E19	10.571	PLATE, DR INR AT LK-RH (BELL CRANK)(W/AU3)	20426398
	E19	10.571	PLATE, DR INR AT LK-LH (BELL CRANK)(W/AU3)	20426399
27.	E18	10.563	ROD, 1/S LK ACTR TO LK-RH (W/AU3)	20344920
	E18	10.563	ROD, 1/S LK ACTR TO LK-LH (W/AU3)	20344921
28.	E17	10.512	KNOB, 1/S LK ROD (BLACK)(10.559)	20832681
29.	E20	10.783	REGULATOR, WDO-RH (MANUAL)(P37)	20302330
	E20	10.783	REGULATOR, WDO-LH (MANUAL)(P37)	20302331
30.	E19	10.687	SUPPORT, WDO GDE RR CAM	20325470
31.	E21	10.792	CAM, WDO GDE-RH	20349886
	E21	10.792	CAM, WDO GDE-LH	20349887
32.	E21	10.792	CAM, INR PNL-RH	20325482
	E21	10.792	CAM, INR PNL-LH	20325483
33.	E17	10.485	ACTUATOR, ELEC LK	22020256
	E17	10.485	BRACKET, ELEC LK ACTR	22049780
34.	E20	10.716	BUMPER, DR WDO REG STOP	20269755
35.	E20	10.783	MOTOR, WDO REG (W/AU3)	22082528
36.	E20	10.783	REGULATOR, WDO-RH (ELEC)	20311752
	E20	10.783	REGULATOR, WDO-LH (ELEC)	20311753
37.	E20	10.703	RETAINER, WDO GDE RUN CHAN-RH	20325458
	E20	10.703	RETAINER, WDO GDE RUN CHAN-LH	20325457
38.	E20	10.703	SUPPORT, RET WDO GDE RUN CHAN	20356700
39.	E19	10.565	CLIP, DR LK R/CONT TO LK ROD	20474324
40.	N22	12.895	BLOCK, DR OTR PNL ATCH (FRT)	20505073
41.	E17	10.454	STRAP, BODY SI LWR HGE-RH	20474593
	E17	10.454	STRAP, BODY SI LWR HGE-LH	20474592
42.	E17	10.454	STRAP, DR SI LWR HGE-RH	20474898
	E17	10.454	STRAP, DR SI LWR HGE-LH	20474899
43.	E17	10.450	STRAP, BODY SI UPR HGE	20475145

44.	E17	10.455	SPRING, LWR HGE	20361482
45.	E17	10.450	STRAP, DR SI UPR HGE-RH	20475146
	E17	10.450	STRAP, DR SI UPR HGE-LH	20475147
46.	E17	10.463	BOLT, LWR HGE TO DR & BDY	20408249
47.	E17	10.468	PIN, UPR & LWR HGE	20430773
48.	E20	10.718	STOP, WDO GLS ON INR PNL	20175950
49.	E19	10.685	STABILIZER, GLS AT BELT	20514937
50.	E19	10.685	RETAINER, WDO GLS BUSH	20096585
51.	E19	10.685	BUTTON, WDO GLS INR	20216819
52.	E19	10.685	BUTTON, WDO GLS STAB	20148473
53.	E19	10.685	BUTTON, WDO GLS OTR	20216820
54.	E19	10.685	BUSHING, WDO GLS (STEEL TYPE(1984)	20178799
	E19	10.685	BUSHING, WDO GLS (1985-88)	20562754

NOTE 1 DEALER WILL BE REQUIRED TO REMOVE CLIP AND REINSERT AT 180 DEGREE ANGLE

NOTE 2 TYPE 1 - USES PUSH-IN RETAINER FOR ATTACHMENT

NOTE 3 TYPE 2 - USES HANG-ON RETAINER FOR ATTACHMENT

PONTIAC BODY GROUP 12.000

ILLUSTRATION INDEX

TITLE	GRID
1984-1985 P MOLDINGS/BODY	G5
1986-1988 P37 MOLDINGS/BODY	G7
1986-1988 P97 MOLDINGS/BODY	G9
1984 P STRIPES/BODY (Y82)	Q10
1984-1987 P STRIPES/BODY SPOILER & MOLDING	G10
1988 P ORNAMENTATION/BODY DECAL & EMBLEM TRIM	Q12
1984-1987 P SHEET METAL/BODY PART 1-BODY-FRONT	G14
1984-1987 P SHEET METAL/BODY PART 2-BODY-CENTER	Q17
1984-1987 P SHEET METAL/BODY PART 3-BODY-REAR	Q20
1988 P SHEET METAL/BODY PART 1-BODY FRONT	Q23
1988 P SHEET METAL/BODY PART 2-BODY-CENTER	Q25
1988 P SHEET METAL/BODY PART 3-BODY-REAR	H3
1984-1988 P ROOF HARDWARE/VISTA VENT (AD3)	H6
1984-1988 P LUGGAGE CARRIER/REAR COMPARTMENT (V58)	H7
1984 P BODY PLASTIC PARTS/EXTERIOR	H9
1985-1988 P37 BODY PLASTIC PARTS/EXTERIOR	H12
1986-1988 P97 BODY PLASTIC PARTS/EXTERIOR	H15
1984-1988 P DOOR HARDWARE/FUEL FILLER	H17
1984-1988 P REAR COMPARTMENT HARDWARE & TRIM	H19

2P12-004
062783

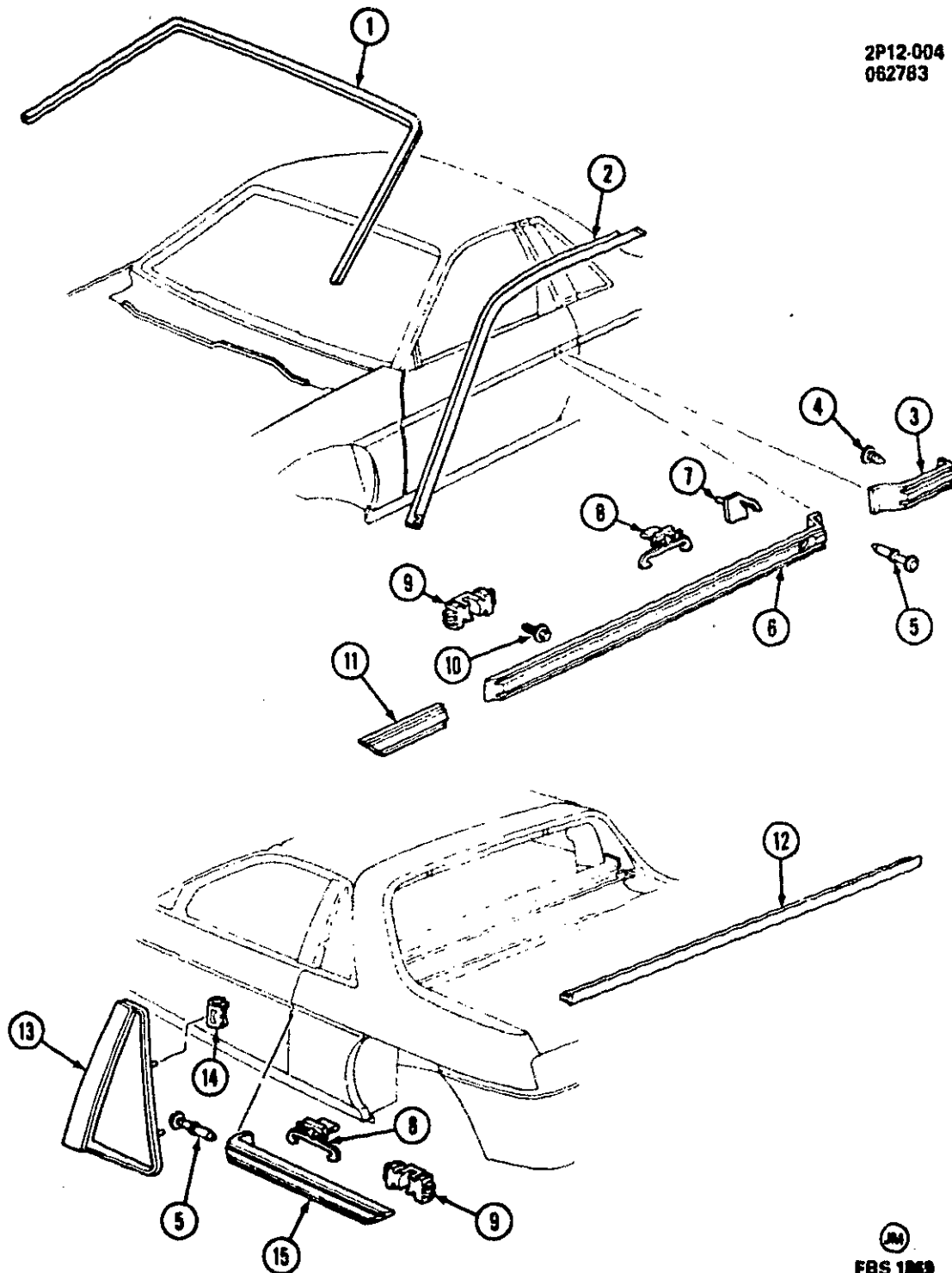

FBS 1069

2P12-004

1984-1985 P MOLDINGS/BODY

NOTE FBS 1869

1	N26	10.093	MOLDING, RVL W S	10103279
2	B6	12.075	MOLDING, RF DRIP RH	20619132
	B6	12.075	MOLDING, RF DRIP LH	20619133
3.	B6	12.112	MOLDING KIT, F/D CTR RR RH (BLA)	20600848
	B6	12.112	MOLDING KIT, F/D CTR RR LH (BLA)	20600849
4.		8.977	SCREW, RD WA HD C/R TAP (M4 2X1.41X20) BLK ORG	
5.	B6	12.118	RETAINER, MLDG RR QTR FRT	20363491
6.	B6	12.112	MOLDING KIT, F/D CTR FRT RH (BLA)	20600829
	B6	12.112	MOLDING KIT, F/D CTR FRT LH (BLA)	20600830
7.	N24	8.133	CLIP, MLDG FDR CTR RR	20696116
8.	B6	12.118	CLIP, MLDG F/D-RR QTR FRT CTR	12337975
9.	B6	12.118	CLIP, MLDG RR QTR FRT CTR	20358051
	B6	12.118	RIVET, RR QTR MLDG (8 133)	20375100
10.		8.977	SCREW, HWH (M4 2 X 2 12)	
11.	N24	8.132	MOLDING KIT, FDR RR OF WHL OPG CTR RH	12327901
	N24	8.132	MOLDING KIT, FDR RR OF WHL OPG CTR LH	12327902
12.	A5	11.208	MOLDING, RVL BK WDO LWR	20446050
13.	B15	12.942	PANEL, APLO QTR QTR UPR W GLASS RH (1984)	20532726
	B15	12.942	PANEL, APLO QTR QTR UPR W GLASS LH (1984)	20532727
	B15	12.942	PANEL, APLO QTR QTR UPR W GLASS RH (W SE)	20532728
	B15	12.942	PANEL, APLO QTR QTR UPR W GLASS LH (W SE)	20532729
	B15	12.942	APPLIQUE, QTR UPR W GLS RH (1985)	20628360
	B15	12.942	APPLIQUE, QTR UPR W GLS LH (1985)	20628361
	B15	12.942	PANEL, APLO QTR QTR UPR (1985)	20628362
14.	A5	11.032	CLIP, APLO QTR QTR UPR	20558350
15.	B6	12.116	MOLDING KIT, RR QTR FRT OF WHL OPG RH	20500825
	B6	12.116	MOLDING KIT, RR QTR FRT OF WHL OPG LH	20500826

2P12-013
123086

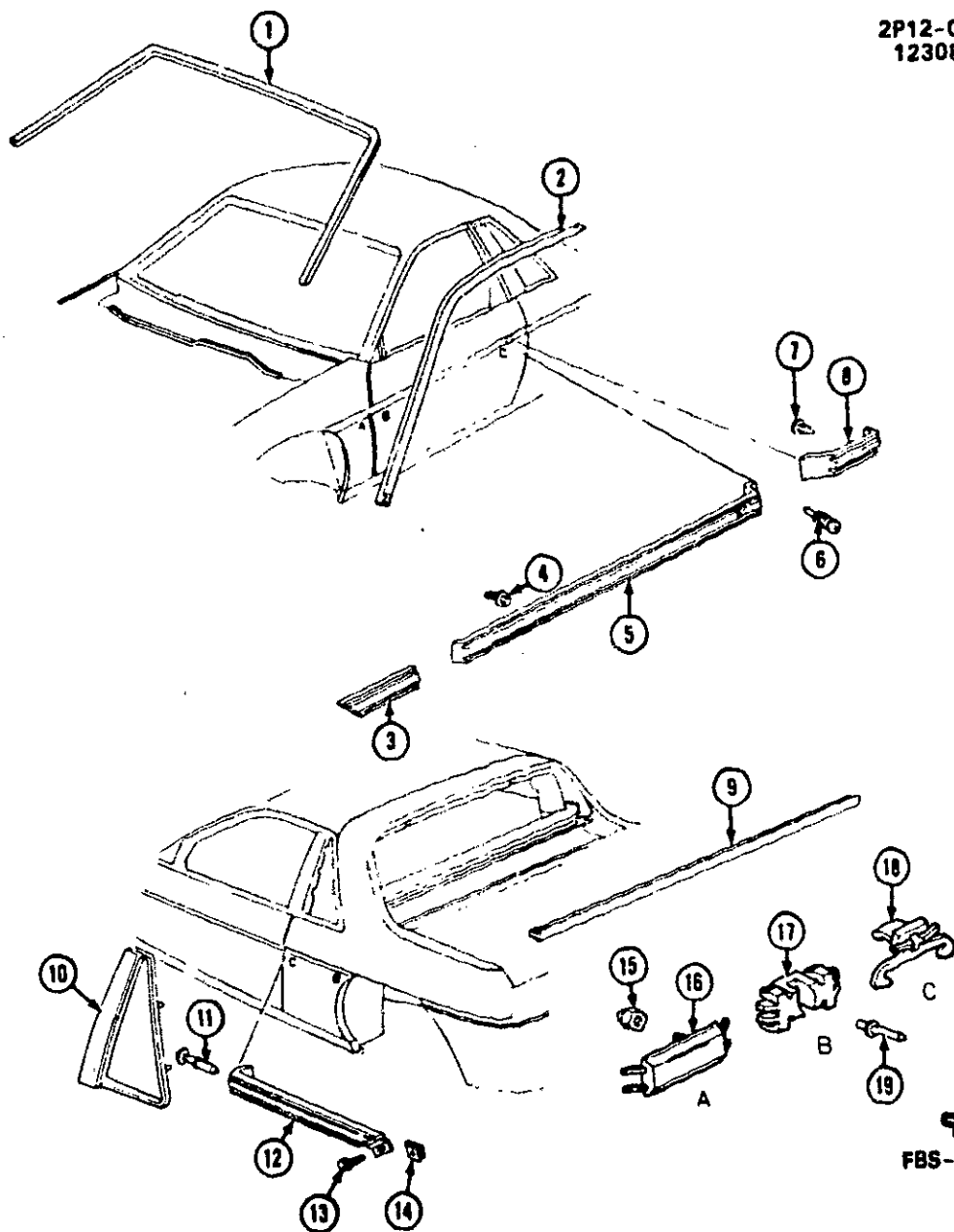



FBS-2100

1986-1988 P37 MOLDINGS/BODY

NOTE: FBS-2100

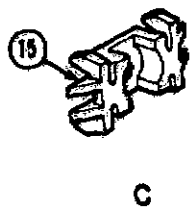
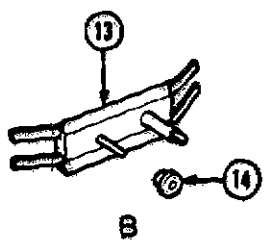
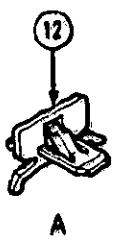
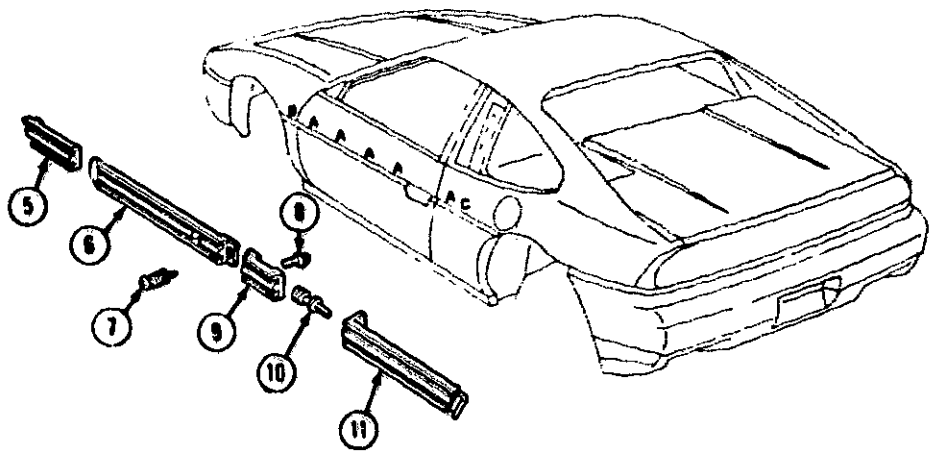
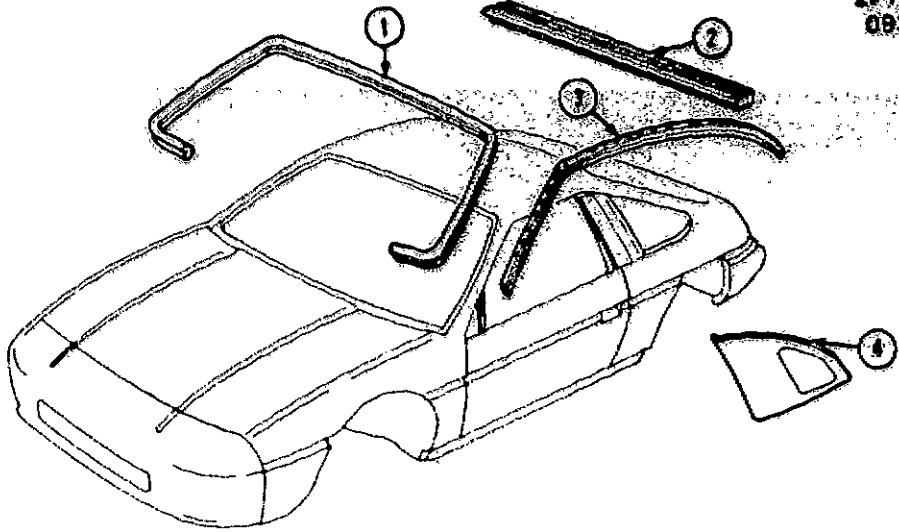
1.	N20	10.093	MOLDING, W/S (BLACK)	10103279
2.	B6	12.075	MOLDING, RF DRIP-RH	20810132
	B6	12.075	MOLDING, RF DRIP-LH	20810133
3.	N24	8.132	MOLDING KIT, F/FDR-RR CTR-LH (BLACK)	12327902
	N24	8.132	MOLDING KIT, F/FDR RR CTR-RH (BLACK)(1986)(W/B97 1987)	12327901
	N24	8.132	MOLDING KIT, F/FDR RR CTR-RH (BLACK)(EXC B97 1987)(1988)	12327903
	N24	8.132	MOLDING KIT, F/FDR RR CTR-LH (BLACK)(EXC B97 1987)(1988)	12327904
4.		8.977	SCREW, HEX W/FL WA (M4.2X2.25X20)POR	11508443
5.	B6	12.112	MOLDING KIT, F/D CTR FRT-RH (BLACK)(1986)(W/B97 1987)	20500829
	B6	12.112	MOLDING KIT, F/D CTR FRT-LH (BLACK)(1986)(W/B97 1987)	20500830
	B6	12.112	MOLDING KIT, F/D CTR FRT-RH (EXC B97 1987)(1988)	20501864
	B6	12.112	MOLDING KIT, F/D CTR FRT-LH (EXC B97 1987)(1988)	20501865
6.	B6	12.118	FASTENER, MLDG F/D RR	20465900
7.		8.977	SCREW, RD WA HD C/R TAP (M4 2X1 41X20) BLK ORG	20378000
8.	B6	12.112	MOLDING KIT, F/D CTR RR-RH (BLACK)(1986)	20500848
	B6	12.112	MOLDING KIT, F/D CTR RR-RH (BLACK)(W/B97 1987)	20500849
	B6	12.112	MOLDING KIT, F/D CTR RR-LH (BLACK)(1986)(W/B97 1987)	20500849
	B6	12.112	MOLDING KIT, F/D CTR RR-RH (EXC B97 1987)(1988)(12 116)	20501862
	B6	12.112	MOLDING KIT, F/D CTR RR-LH (EXC B97 1987)(1988)(12 116)	20501863
9.	A5	11.208	MOLDING, BK WDO LWR (BLACK)	20448050
10.	B15	12.942	APPLIQUE, QTR UPR-RH (W/B57 1986-87)	20828360
	B15	12.942	APPLIQUE, QTR UPR-LH (W/B57 1986-87)	20828361
	B15	12.942	APPLIQUE, QTR UPR-RH (EXC B57 1986-87)(1988)	20828358
	B15	12.942	APPLIQUE, QTR UPR-LH (EXC B57 1986-87)(1988)	20828359
11.	B6	12.118	RETAINER, MLDG RR-QTR FRT	20363481
12.	B6	12.116	MOLDING KIT, RR QTR CTR FRT-RH (BLACK)(1986)(W/B97 1987)	20500825
	B6	12.116	MOLDING KIT, RR QTR CTR FRT-LH (BLACK)(1986)(W/B97 1987)	20500826
	B6	12.116	MOLDING KIT, RR QTR CTR FRT-RH (EXC B97 1987)(1988)	12390771
	B6	12.116	MOLDING KIT, RR QTR CTR FRT-LH (EXC B97 1987)(1988)	12390772
13.		8.977	SCREW, HEX TAP W/WA (M4 2X1 41X16) POR	10021798
14.		8.921	NUT, U-SHAPE (M4 2X1 41)ZOR	52351724
15.		8.921	NUT, HEX STMPD W/SLR (M6X1)ZOR	11505885
16.	N24	8.133	CLIP, MLDG F/FDR CTR RR	20598116
17.	B6	12.118	CLIP, MLDG F/D. RR QTR FRT CTR (37MM LONG)	20356051
18.	B6	12.118	CLIP, MLDG F/D. RR QTR FRT CTR (54MM LONG)	12337975
19.	B6	12.118	RIVET, RR QTR MLDG (1985)(8 133)	20433026



1986-1988 P97 MOLDINGS/BODY

1.	N26	10.093	MOLDING, W/S (BLACK)	10103279
2.	A5	11.208	MOLDING, BK WDO LWR (BLACK)	20446050
3.	88	12.075	MOLDING, RF DRIP-RH (BLACK)	10118462
	88	12.075	MOLDING, RF DRIP-LH (BLACK)	10118463
4.	A5	11.011	WINDOW, RR QTR VISION-RH	20701108
	A5	11.011	WINDOW, RR QTR VISION-LH (1986-88)	20701107
5.	N24	8.132	MOLDING KIT, F/FDR RR-RH (BLACK)	12327903
	N24	8.132	MOLDING KIT, F/FDR RR-LH (BLACK)	12327904
6.	88	12.112	MOLDING KIT, F/D CTR-FRT-RH	20501864
	88	12.112	MOLDING KIT, F/D CTR-FRT-LH	20501865
7.	88	12.118	FASTENER, MLDG, F/D RR	20455900
8.		8.977	SCREW, RD WA HD C/R TAP (M4 2X1.41X20) BLK ORG	20378000
9.	88	12.112	MOLDING KIT, F/D CTR RR-RH (12 116)	20501862
	88	12.112	MOLDING KIT, F/D CTR RR-LH (12 116)	20501863
10.	88	12.118	RETAINER, MLDG RR QTR FRT	20383491
11.	88	12.118	MOLDING KIT, RR QTR CTR FRT-RH	12390771
	88	12.118	MOLDING KIT, RR QTR CTR FRT-LH	12390772
12.	88	12.118	CLIP, MLDG F/D, RR QTR-FRT CTR (54MM LONG)	12337975
13.	N24	8.133	CLIP, MLDG F/FDR CTR RR	20598116
14.		8.921	NUT, HEX STMPD W/SLR (M6X1) ZOR	11505865
15.	88	12.118	CLIP, MLDG F/D CTR (37MM LONG)	20356051

2P12-009
041384

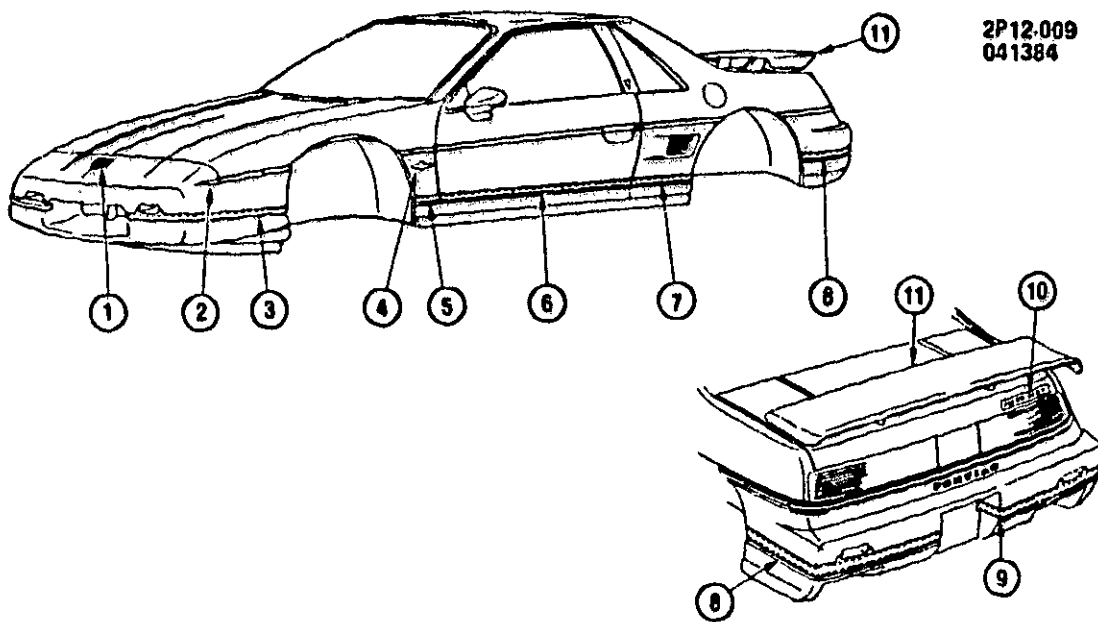

2P12-009

**1984 P STRIPES/BODY (Y82)
1984-1987 P STRIPES/BODY SPOILER & MOLDING**

1.	N22	7.832	EMBLEM, FRT BPR FASCIA(* 1)	10032011
2.	N22	7.832	MOLDING, FRT BPR FASCIA-RH	10038511
	N22	7.832	MOLDING, FRT BPR FASCIA-LH	10038512
3.	N16	1.263	STRIPE, F/END PNL-RH(* 1)	10032863
	N16	1.263	STRIPE, F/END PNL-LH(* 1)	10032864
4.	N24	8.147	PLATE, FDR NA "INDIANAPOLIS MOTOR SPEEDWAY"(* 1)	10031688
5.	N24	8.132	STRIPE, FDR RR-RH(* 1)	10032869
	N24	8.132	STRIPE, FDR RR-LH(* 1)	10032870
6.	B6	12.112	STRIPE, DOOR(* 1)	10032871
7.	B6	12.116	STRIPE, RR QTR FRT RH(* 1)	10032872
	B6	12.116	STRIPE, RR QTR FRT LH(* 1)	10032873
8.	N22	7.832	STRIPE, RR BPR FASCIA-LH(* 1)	10032866
9.	N22	7.832	STRIPE, RR BPR FASCIA-RH(* 1)	10032865
10.	B8	12.182	DECAL, RR COMPT LID "FIERO INDY"(* 1)	10032862
11.	B7	12.181	SPOILER, RR COMPT LID AIR (D80XP37X* 2)	10077408
	B7	12.181	SPOILER, RR COMPT LID AIR (P97X* 2)	10077408

NOTE 1 Y82 OPTION 1984 ONLY

NOTE 2 PAINT AS REQUIRED

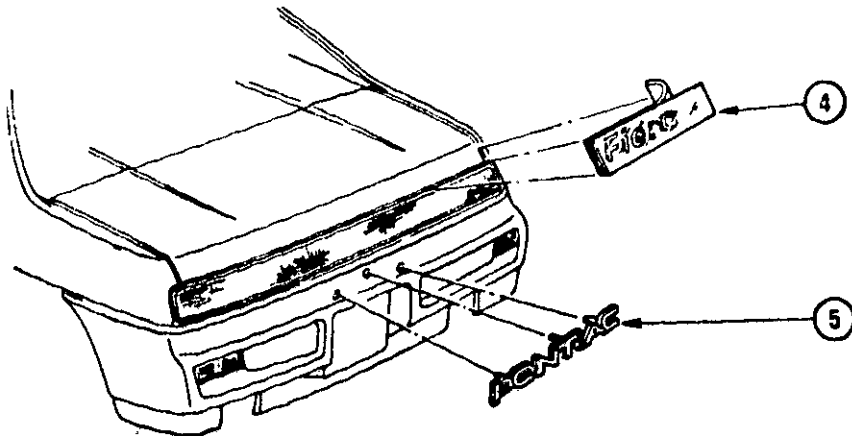
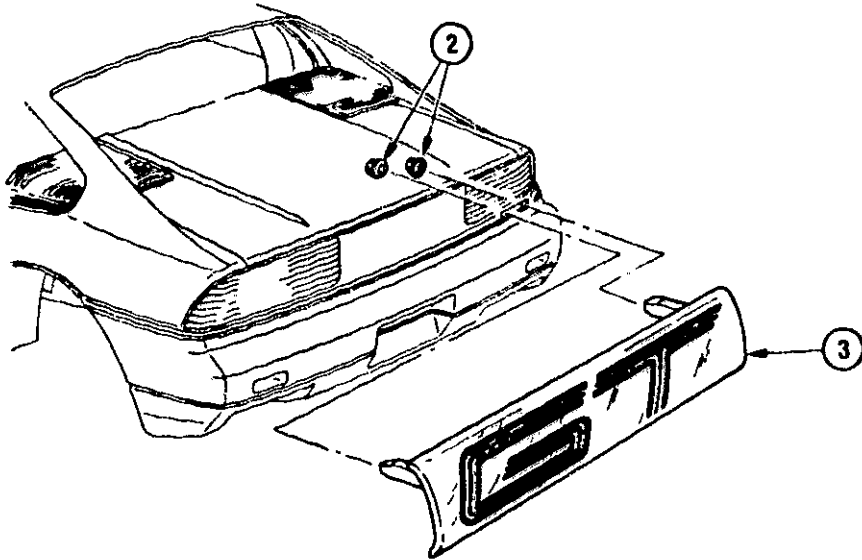
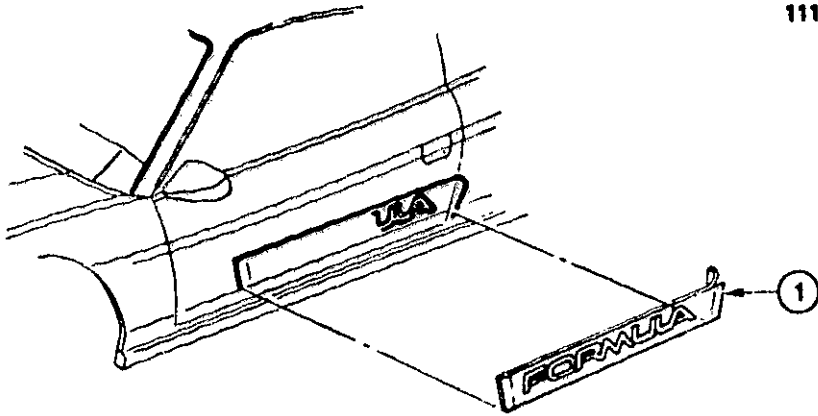

1988 P ORNAMENTATION/BODY DECAL & EMBLEM TRIM

1.	86	12.112	DECAL, F/D NA "FORMULA" (MED GRA METHP37)W/W66	10051982
	86	12.112	DECAL, F/D NA "FORMULA" (SLV METHP37)W/W66	10051981
2.		8.921	NUT, MET SKW FLG (M5X15)PHOS	11501047
3.	N21	7.831	EMBLEM, RR BPR FASCIA (P97)	10052324
4.	88	12.182	DECAL, RR COMPT LID NA "FIERO" (BLA)P37)	10055329
	88	12.182	DECAL, RR COMPT LID NA "FIERO" (SLV)P37)	10055330
5.	N22	7.832	PLATE, RR BPR FASCIA NA "PONTIAC" (SLV)P37)	10055156

2P12-005
021788

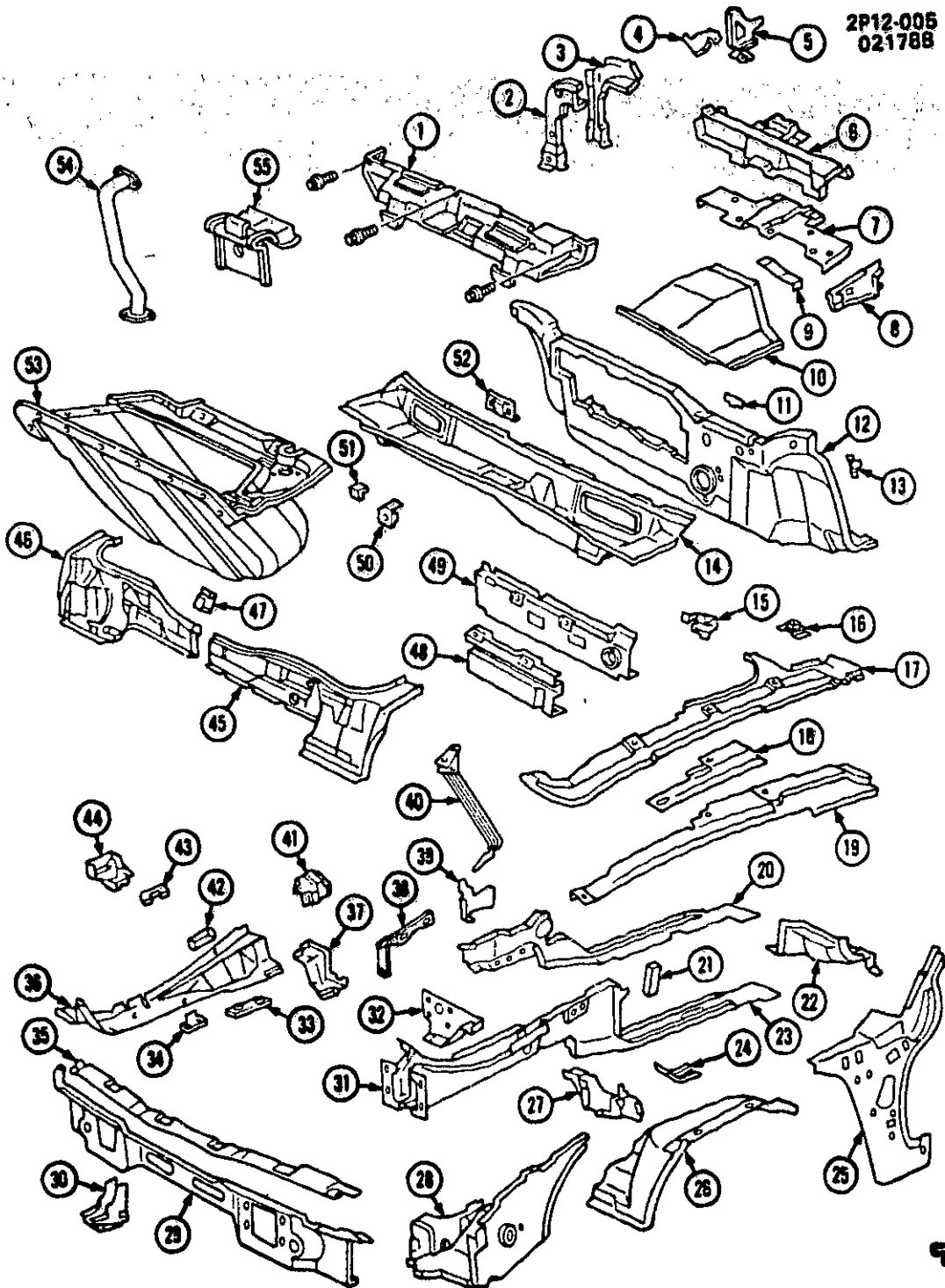

2P12-005

1984-1987 P SHEET METAL/ BODY PART 1-BODY-FRONT

1.	B11	12.810	COVER, RF VENT GLS STOW (W/AD3)	20680013
2.	N19	6.760	SUPPORT, STRG COL SUPT BRKT	20620366
3.	N18	6.758	SUPPORT, STRG COL UPR	7839279
4.	N19	6.760	BRACE, STRG COL SUPT BRKT	20314672
5.	N19	6.760	BRACE, STRG COL SUPT	20416386
6.	N18	6.758	BRACKET, STRG COL UPR	20680283
7.	N18	6.758	SUPPORT, STRG COL LWR	20604887
8.	N18	6.758	BRACKET, STRG COL SUPT LWR-RH	20589026
	N18	6.758	BRACKET, STRG COL SUPT LWR-LH	20610462
9.	N18	6.758	BRACE, STRG COL UPR TO LWR OTR	20653219
10.		N.S.	PANEL, FLR PAN TUN EXT FRT	
11.		N.S.	CLIP, WRG ANT CBL TO PNL DA	
12.	B11	12.804	PANEL, DA (W/NUT)	20616083
13.		N.S.	SUPPORT, DA PNL SOUND ABS	
14.		N.S.	PANEL, SHRD TOP VENT DUCT	
15.	N17	3.452	SUPPORT, ACCEL MT	20519461
16.	B15	12.940	BLOCK, OTR UPR PNL ATCH (1 269)(PART OF 17 & 29)	20338249
17.	N19	7.006	RAIL, F/COMPT SI UPR-RH (INCL 16.18.19)	12391170
	N19	7.006	RAIL, F/COMPT SI UPR-LH (INCL 16.18.19)	12391171
	N19	7.006	RAIL, F/COMPT SI UPR-RH (LESS BLK.PLT.REINF)	12391170
	N19	7.006	RAIL, F/COMPT SI UPR-LH (LESS BLK.PLT.REINF)	12391171
18.	B19	12.986	PLATE, F/COMPT UPR RL REINF-RH (PART OF 17)	12391170
	B19	12.986	PLATE, F/COMPT UPR RL REINF-LH (PART OF 17)	20622146
19.		N.S.	REINFORCEMENT, F/CPMT SI UPR (PART OF ITEM 17)	
20.	N19	7.006	RAIL, F/COMPT SI LWR RR INR-RH	20637122
	N19	7.006	RAIL, F/COMPT SI LWR RR INR-LH (1984-85)	20307349
	N19	7.006	RAIL, F/COMPT SI LWR RR INR-LH (1986-87)	20637121
21.	N19	7.006	BRACKET, RL OTR LWR TO TORQ BAR (1984-86)	20355584
22.	B19	12.986	REINFORCEMENT, DA PNL LWR OTR SI-RH	20307226
	B19	12.986	REINFORCEMENT, DA PNL LWR OTR SI-LH	20307227
23.	N19	7.006	RAIL, F/COMPT SI LWR RR OTR-RH (1984-85)	20334416
	N19	7.006	RAIL, F/COMPT SI LWR RR OTR-LH (1986-87)	20692114
	N19	7.006	RAIL, F/COMPT SI LWR RR OTR-LH	20692115
24.	N25	8.155	REINFORCEMENT, F/COMPT RL LWR FRT TO DA-RH	20314570
	N25	8.155	REINFORCEMENT, F/COMPT RL LWR FRT TO DA-LH	20314571
25.	B12	12.840	PANEL, FRT BODY H/PLR INR-RH	20636330
	B12	12.840	PANEL, FRT BODY H/PLR INR-LH	20636331
26.	N24	8.153	PANEL, LWR COMPT SI & W/H-RH (1984-85)	20493790
	N24	8.153	PANEL, LWR COMPT SI & W/H-RH (1986-87)	20649408
	N24	8.153	PANEL, LWR COMPT SI & W/H-LH	20493791
27.	N18	6.177	BRACKET, LWR CONT ARM MT-RH	20661346
	N18	6.177	BRACKET, LWR CONT ARM MT-LH	20661347
28.	N24	8.153	EXTENSION, F/COMPT & W/H SI-RH	10119920
	N24	8.153	EXTENSION, F/COMPT & W/H SI-LH	10084335
29.	N16	1.263	PANEL, F/END MT (INCL 16 & 35)	12391169
30.	N19	7.006	SUPPORT, TOW F/COMPT LWR RL-RH (1984-86)	20355582
	N19	7.006	SUPPORT, TOW F/COMPT LWR RL-LH (1984-86)	20355583
31.	N19	7.006	RAIL, F/COMPT SI LWR FRT & C/NUT-RH	20698244
	N19	7.006	RAIL, F/COMPT SI LWR FRT & C/NUT-LH	20698245
32.	N20	7.009	EXTENSION, F/COMPT LWR RL RR TO DA-LH	20692105
33.	N20	7.330	PLATE, TAP FRT SUSP MT LWR HORIZ	20355804
34.	B18	12.980	PLATE, F/COMPT STAB BAR ON LWR FRT RL-RH (1984-85)	20355586
35.	N16	1.263	BAR, F/END UPR TIE (PART OF 29)	
36.	N19	7.006	RAIL, L/COMPT SI LWR FRT UPR-RH (W/NUT)	10071768
	N19	7.006	RAIL, L/COMPT SI LWR FRT UPR-LH (W/NUT)	10071769
37.	N20	7.009	EXTENSION, F/COMPT LWR RL RR TO DA-RH	20692104
38.	N23	8.015	HINGE, F/COMPT-RH	20594604
	N23	8.015	HINGE, F/COMPT-LH	20594605
39.	N19	7.006	REINFORCEMENT, F/COMPT RL INS INR TO OTR-RH	20429020
	N19	7.006	REINFORCEMENT, F/COMPT RL INS INR TO OTR-LH	20429021
40.	N23	8.015	SUPPORT, F/COMPT LID	20379366
41.	N20	7.395	SUPPORT, FRT S/ABS MT-RH	20341744
	N20	7.395	SUPPORT, FRT S/ABS MT-LH	20341745
42.	N18	6.008	BRACKET, FRT SUSP MT UPR-RH	20355588
	N18	6.008	BRACKET, FRT SUSP MT UPR-LH	20355587
43.	N20	7.330	PLATE, FRT SUSP MT LWR VERT TAP (1984-85)	20355586
44.	N19	7.006	REINFORCEMENT, F/COMPT RL INR FRT SUSP-RH (1984-86)	20357436
	N19	7.006	REINFORCEMENT, F/COMPT RL INR FRT SUSP-LH (1984-86)	20357437
45.	N17	2.726	PANEL, F/COMPT & HDLP MT-LH (INCL 47)	10074071
46.	N17	2.726	PANEL, F/COMPT & HDLP MT-RH	20601014
47.	N25	8.820	RETAINER, JACK HDL STOW ON LH F/COMPT PNL (PART OF 45)	20418326
48.		N.S.	REINFORCEMENT, BAR TORQ FRT	
49.		N.S.	BAR, TORQ FRT	

50.	N.S.	SUPPORT, 1/P END
51.	N.S.	BRACKET, FRT COMPT TR
52.	N.S.	REINFORCEMENT, SHRD PNL F/COMPT LK
53.	N26	POCKET, SPA WHL
54.	011	HOSE, DRN SHRD TOP VENT DUCT-RH
54.	011	HOSE, DRN SHRD TOP VENT DUCT-LH
55.	012	RETAINER, RF VENT STOW (W/AD3)

20816553
20314576
20314577
20379691

2P12-011
021789

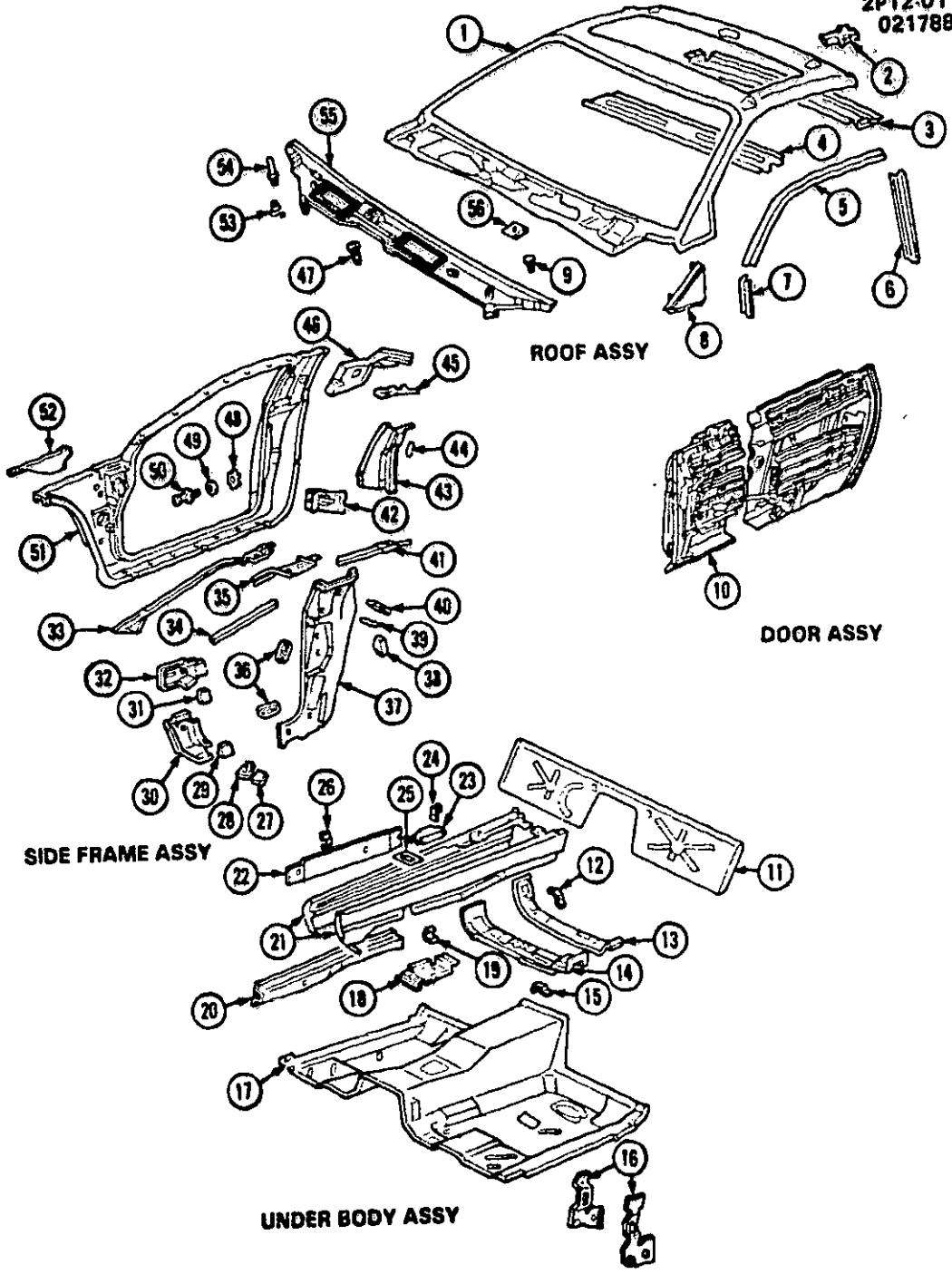

1984-1987 P SHEET METAL/BODY PART 2-BODY-CENTER

1.	B11	12.810	PANEL, RF (STL)	20816555
2.		N.S.	REINFORCEMENT, LIFT OFF RF OPG OTR RR	
3.	B18	12.984	PANEL, BK WDO INR UPR (1984-85)	20568807
	B18	12.984	PANEL, BK WDO INR UPR (1986-87)	20681067
4.	B11	12.807	FRAME, W/S INR UPR (W/RF VENT)	20680079
5.	N28	10.721	RETAINER, W/S SI RF RL-RH	20320526
	N28	10.721	RETAINER, W/S SI RF RL-LH	20320527
6.	N28	10.721	RETAINER, W/STR BODY LK PLR-RH (INCL CLIP)	20320548
	N28	10.721	RETAINER, W/STR BODY LK PLR-LH (INCL CLIP)	20320549
	N28	10.695	CLIP, GDE WDO	20320530
7.	N28	10.695	RETAINER, W/STR H/PLR UPR-RH	20320584
	N28	10.695	RETAINER, W/STR H/PLR UPR-LH	20320585
8.	B11	12.807	FILLER, W/S FRM AT BELT-RH (1984-85)	20348398
	B11	12.807	FILLER, W/S FRM AT BELT-LH (1984-85)	20348399
	B11	12.807	FILLER, W/S FRM AT BELT-RH (1986-87)	20594740
	B11	12.807	FILLER, W/S FRM AT BELT-LH (1986-87)	20594741
9.	B10	12.800	FASTENER, SCRNR TOP VENT TO RF PNL CVR	20511451
10.	B12	12.895	PANEL, INR-RH (W/OTR REINF) 1984-85)	20459366
	B12	12.895	PANEL, INR-RH (W/OTR REINF) 1986-87)	10116314
	B12	12.895	PANEL, INR-LH (W/OTR REINF)	10116315
11.		N.S.	PANEL, FLR PAN EXT RR LWR	
12.		N.S.	SUPPORT, HTR & A/C LINES FLR PAN	
13.		N.S.	REINFORCEMENT, FLR PAN AT ST ADJ RR	
14.		N.S.	REINFORCEMENT, FLR PAN AT ST ADJ FRT	
15.		N.S.	RETAINER, COOLANT HOSE CLAMP	
16.	D12	14.875	BRACKET, ST BELT ANC & HNDR STRP-RH (1987)X3 015)	10054694
	D12	14.875	BRACKET, ST BELT ANC & HNDR STRP-LH (1987)X3 015)	10054693
17.		N.S.	PAN, FLR	
18.		N.S.	SUPPORT, GEAR SHIFT	
19.		N.S.	SUPPORT, STRP FRT	
20.		N.S.	SUPPORT, REINF UPR	
21.		N.S.	REINFORCEMENT, FLR PAN UPR	
22.	B13	12.934	PANEL, RKR INR-RH (INCL 26)	20636328
	B13	12.934	PANEL, RKR INR-LH (INCL 26)	20636329
23.		N.S.	PLATE, JACKING ON FLR PAN	
24.	E5	15.100	RETAINER, TR OTR PNL INR	20348030
25.		N.S.	STRAP, REINF UPR	
26.		N.S.	SUPPORT, TR ON RKR INR (PART OF 22)	
27.		N.S.	PLATE, BFL INR FRT BODY HGE	
28.		N.S.	PLATE, BFL OTR BODY HGE	
29.		N.S.	PLATE, ANC UPR HGE (BODY SI)	
30.	B12	12.840	REINFORCEMENT, H/PLR AT LWR HGE-RH (1985-87)	20547852
	B12	12.840	REINFORCEMENT, H/PLR AT LWR HGE-LH (1985-87)	20547853
31.	N27	10.454	PLATE, ANC LWR HGE-RH (BODY SI)	20521324
	N27	10.454	PLATE, ANC LWR HGE-LH (BODY SI)	20521325
32.	B12	12.840	REINFORCEMENT, H/PLR AT UPR HGE RH	20307354
	B12	12.840	REINFORCEMENT, H/PLR AT UPR HGE-LH	20307355
33.	B11	12.807	FRAME, W/S SI INR-RH	20615094
	B11	12.807	FRAME, W/S SI INR-LH	20479017
34.	B11	12.807	REINFORCEMENT, W/S SI FRM-RH	20330794
	B11	12.807	REINFORCEMENT, W/S SI FRM-LH	20330795
35.	B11	12.807	REINFORCEMENT, W/S INR UPR COR-RH (1984-85)	20330792
	B11	12.807	REINFORCEMENT, W/S INR UPR COR-LH (1984-85)	20692087
	B11	12.807	REINFORCEMENT, W/S INR UPR COR-RH (1986-87)	20692088
	B11	12.807	REINFORCEMENT, W/S INR UPR COR-LH (1986-87)	20692087
36.		N.S.	PLATE, ANC ST BELT	
37.	D12	14.731	PANEL, BODY LK PLR INR LWR-RH (W/O MTG SPKR)	20692080
	D12	14.731	PANEL, BODY LK PLR INR LWR-LH (W/MTG SPKR)	20692081
38.	B15	12.942	REINFORCEMENT, BODY LK PLR INR LWR-RH	20367356
	B15	12.942	REINFORCEMENT, BODY LK PLR INR LWR-LH	20367359
39.		N.S.	PLATE, BFL BODY LK PLR LWR OTR	
40.		N.S.	PLATE, BFL BODY LK PLR LWR INR	
41.	B18	12.957	RAIL, RF INR SI-RH	20307362
	B18	12.957	RAIL, RF INR SI-LH	20307363
42.	B15	12.942	REINFORCEMENT, BODY LK AT LK STKR-RH	20334408
	B15	12.942	REINFORCEMENT, BODY LK AT LK STKR-LH	20334409
43.	B15	12.942	REINFORCEMENT, BODY LK PLR UPR-RH	20692082
	B15	12.942	REINFORCEMENT, BODY LK PLR UPR-LH	20692083
44.		N.S.	PLATE, CTR PLR UPR & SHLDR BELT ANC	
45.	B15	12.942	EXTENSION, REINF BODY LK PLR TO FRM BODY-RH	20325538
	B15	12.942	EXTENSION, REINF BODY LK PLR TO FRM BODY-LH	20325539
46.	D12	14.731	PANEL, BODY LK PLR INR UPR-RH	20563186
	D12	14.731	PANEL, BODY LK PLR INR UPR-LH	20563187

47.		8.977	SCREW, RD LRG WA HD (M4 2X1 4) X25)	11505850
48.	N28	10.571	PLATE, LK STKR ANC	20277001
49.		8.929	WASHER, FLAT (M11 X40X3)	11500387
50.	N27	10.569	STRIKER, LK (INCL WA)	20464563
		8.929	WASHER, FLAT (M13 X45X1 5)	1260895
51.	N19	7.006	FRAME, BODY SI-RH	10074046
	N19	7.006	FRAME, BODY SI-LH	20694755
52.	N19	7.006	REINFORCEMENT, BODY H/PLR QTR PNL UPR-RH	20429018
	N19	7.006	REINFORCEMENT, BODY H/PLR QTR PNL UPR-LH	20429019
53.	N23	8.083	SPRING, HOOD POP-UP	20472201
54.	B13	12.934	RIVET, PNL W/H LNR FRT TO PNL (8 133)	20433026
55.	B10	12.800	SCREEN, SHRD TOP VENT (1984-85)	20559921
	B10	12.800	SCREEN, SHRD TOP VENT (1986-87)	10074271
56.		N.S.	REINFORCEMENT, W/S WIPER TRANS MTG	

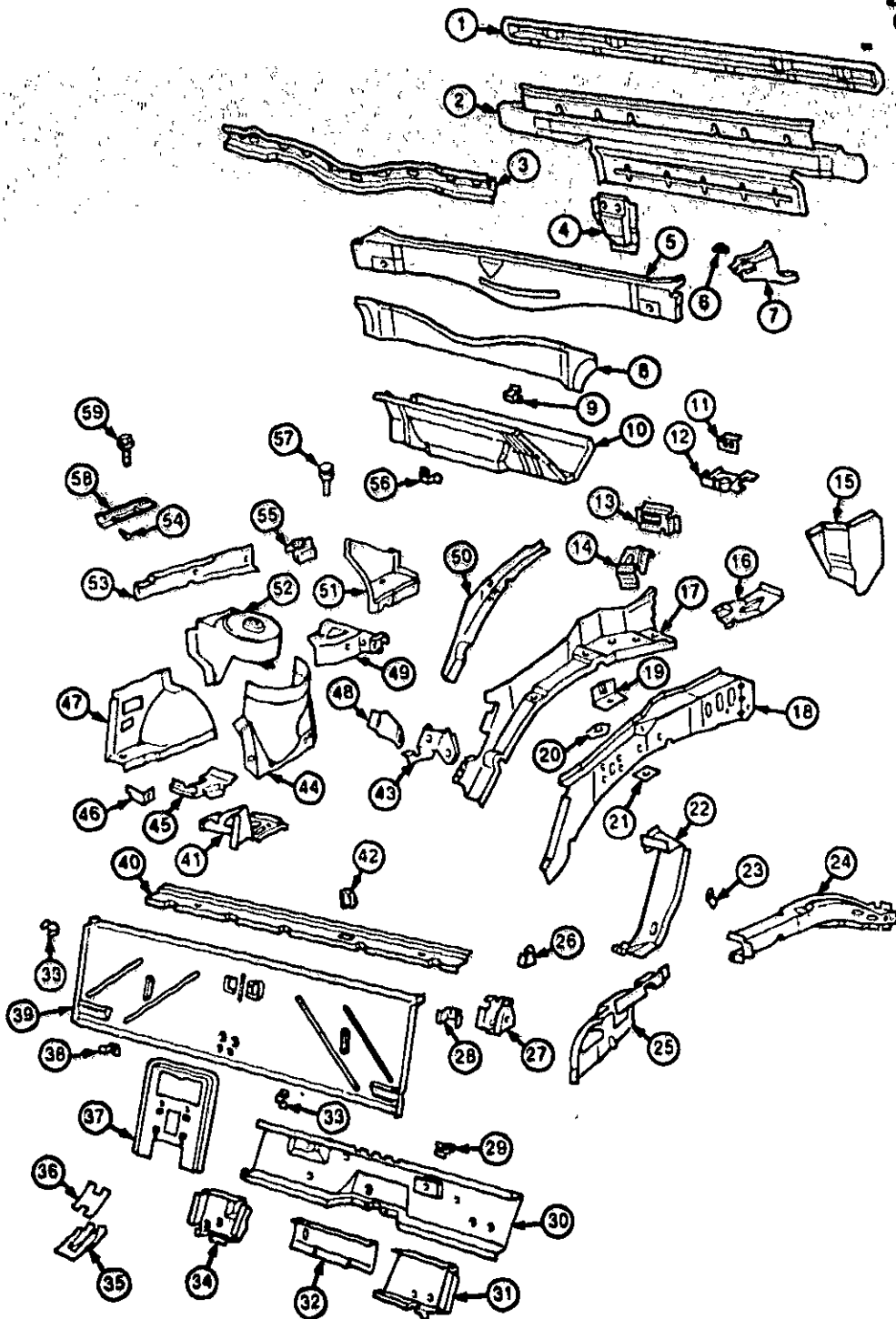

1984-1987 P SHEET METAL/BODY PART 3-BODY-REAR

1.	B18	12.968	REINFORCEMENT, R/END PNL UPR (PART OF 2)	20598051
2.	B18	12.968	PANEL, R/END (INR)INCL 1 4 6)	12391172
3.	B19	12.986	BAR, ENG COMPT RR CR	20622160
4.	N.S.		SUPPORT, RR COMPT L/WDO LK STKR (PART OF 2)	
5.	B16	12.944	REINFORCEMENT, MTR COMPT RR CR BAR	20880119
6.	B15	12.940	BLOCK, QTR UPR PNL ATCH (PART OF 2 & 24)1 269)	20338249
7.	N19	7.008	EXTENSION, MTR COMPT RL SI UPR-RH (1984)	20631623
	N19	7.008	EXTENSION, MTR COMPT RL SI UPR-RH (1985-87)1)	20631623
	N19	7.008	EXTENSION, MTR COMPT RL SI UPR-LH	20322899
8.	B16	12.944	PANEL, MTR COMPT RR	20828872
9.	N24	8.153	BRACKET, MTR COMPT DUST SHLD (1985-86)	20884080
10.	B7	12.181	PANEL, RR COMPT LWR	20305670
11.	B7	12.181	PLATE, RR COMPT MTR CVR SI-RH (P37)	20493866
	B7	12.181	PLATE, RR COMPT MTR CVR SI-LH (P37)	20493867
12.	B7	12.181	SUPPORT, RR COMPT MTR CVR SI RH (P37)	20328080
	B7	12.181	SUPPORT, RR COMPT MTR CVR SI-LH (P37)	20328081
13.	N18	3.855	SUPPORT, CR/CONT (MT ON RR CR BAR REINFR1985 87)	20532722
14.	N18	3.855	SUPPORT, CR/CONT MT TO SHK HSG UPR (1984)	20357428
15.	B16	12.944	PANEL, RR COMPT SI-RH	20320570
	B16	12.944	PANEL, RR COMPT SI-LH	20320571
16.	B18	12.981	PANEL, RR COMPT UPR RH	20320568
	B18	12.981	PANEL, RR COMPT UPR-LH	20320569
17.	B19	12.986	RAIL, MTR COMPT SI INR-RH	20626368
	B19	12.986	RAIL, MTR COMPT SI INR-LH	20815081
18.	B19	12.986	RAIL, MTR COMPT SI OTR-RH	20626369
	B19	12.986	RAIL, MTR COMPT SI OTR-LH	20492776
19.	B19	12.986	REINFORCEMENT, MTR COMPT LWR RL AT RR CRADLE MT RH	20314628
	B19	12.986	REINFORCEMENT, MTR COMPT LWR RL AT RR CRADLE MT LH	20314629
20.	N15	0.029	RETAINER, MTR COMPT CRADLE MT RR NUT RH	20341732
	N15	0.029	RETAINER, MTR COMPT CRADLE MT RR NUT LH	20341733
21.	N15	0.029	PLATE, RR CRADLE MT TO TAIL LWR INR	20363478
22.	B19	12.986	EXTENSION, MTR COMPT SI RL OTR TO LWR PLR INR-RH	10071619
	B19	12.986	EXTENSION, MTR COMPT SI RL OTR TO LWR PLR INR-LH	20534623
23.	N16	1.168	RETAINER, COOL LINE ON OTR LWR RL (1984)	20351038
24.	B19	12.986	RAIL, MTR COMPT SI UPR-RH (INCL 6 & 53)	12391174
	B19	12.986	RAIL, MTR COMPT SI UPR-LH (INCL 6 & 53)	12391173
	B19	12.986	RAIL, MTR COMPT SI UPR-RH (1985)LESS BLK REINF)	12391174
	B19	12.986	RAIL, MTR COMPT SI UPR-RH (1986 87)LESS BLK REINF)	20624929
25.	B16	12.944	PANEL, RR W/H FRT LH (1984)	20305681
	B16	12.944	PANEL, RR W/H FRT INR-LH (1985 87)	20492799
26.	N.S.		BRACKET, TORQ ROD RET (PART OF 27)	
27.	B9	12.184	SUPPORT, RR COMPT LID AT HGE RH (INCL 26)	20513475
	B9	12.184	SUPPORT, RR COMPT LID AT HGE LH (INCL 26)	20638949
28.	N.S.		SUPPORT, VAC LINE & WRG CLIP ON FLR PAN EXT RR UPR	
29.	N.S.		SUPPORT, HT SHLD LWR ON RR TORQ BAR	
30.	N.S.		BAR, TORQ RR	
31.	N.S.		REINFORCEMENT, RR TORQ BAR LH	
32.	N.S.		REINFORCEMENT, RR TORQ BAR CVR	
33.	B16	12.981	RETAINER, MTR COMPT INSL	20346032
34.	N.S.		REINFORCEMENT, RR TORQ BAR-RH	
35.	B19	12.986	EXTENSION, MTR COMPT LWR RL	20314632
36.	N.S.		REINFORCEMENT, ENG COMPT INR SI RL EXT	
37.	N.S.		SUPPORT, PNL FLR PAN EXT UPR RR	
38.	N.S.		BRACKET, HTR INL PIPE	
39.	N.S.		PANEL, BODY F/ST BK	
40.	N.S.		ABSORBER, BODY F/ST BK PNL SOUND	
41.	N16	2.333	TRAY, BAT (1984-86)	10071787
	N16	2.333	TRAY, BAT (1987)	10071787
42.	N19	7.008	SUPPORT, MTR COMPT J/BLK ON EXT FLR PAN (1984)	20346017
43.	N.S.		SUPPORT, MTR COMPT FRT CRADLE	
44.	N20	7.395	HOUSING, S/ABS MTR COMPT LWR-RH	20305688
	N20	7.395	HOUSING, S/ABS MTR COMPT LWR-LH	20566281
45.	N16	2.333	SUPPORT, BAT HOLDN	20489129
46.	N.S.		SUPPORT, FUEL LINE & HT SHLD	
47.	B16	12.944	PANEL, RR W/H FRT INR-RH (1984-85-87)	20880575
48.	B19	12.986	BRACE, MTR COMPT FRT CRADLE MT-RH (1984-87)	20593140
	B19	12.986	BRACE, MTR COMPT FRT CRADLE MT-LH	20557029
49.	N20	7.242	SUPPORT, TORQ STRUT	20521264
50.	B19	12.986	REINFORCEMENT, RR LWR INR RL AT FRT-RH	10092161
	B19	12.986	REINFORCEMENT, RR LWR INR RL AT FRT-LH	10103881
51.	B16	12.944	PANEL, RR W/H RR INR-RH	20307358
	B16	12.944	PANEL, RR W/H RR INR-LH	20307359
52.	N20	7.395	HOUSING, S/ABS MTR COMPT UPR-RH	20305686

52.	N20	7.395	HOUSING, S/ABS MTR COMPT UPR-LH	20592100
53.	B19	12.988	REINFORCEMENT, MTR COMPT SI UPR RL RH (PART OF 24)	20556172
		N.S.	REINFORCEMENT, MTR COMPT SI UPR RL LH (PART OF 24)	
54.	B7	12.181	RETAINER, RR COMPT MTR CVR SI (P37 1984-86)	20351044
	B7	12.181	RETAINER, RR COMPT MTR CVR SI (P37 1987)	20513451
55.	N20	7.395	SUPPORT, FRT S/ABS MT-RH	20341744
	N20	7.395	SUPPORT, FRT S/ABS MT-LH	20341745
56.	N18	3.708	RETAINER, HT SHLD AT MUFF ON RR COMPT LWR	20346033
57.	B9	12.184	BUMPER, MTR COMPT CVR SI (P37)(PART OF 58)(12 810)	20485423
	B15	12.940	BUMPER, ENG COMPT UPR SI GRL (P97 1986-87)(PART OF 58)(12 810)	20485423
58.	B7	12.181	EXTENSION, MTR COMPT CVR SI-RH (INCL 57)	20667588
	B7	12.181	EXTENSION, MTR COMPT CVR SI-LH (INCL 57)	20667589
59.		8.977	SCREW, PAN HD TORX W/FL WA TAP (M6 3X1 81X30) PZOR	11507094

NOTE 1 WHEN USING FOR 2 5R ENGINE TWO PLUGS TO THE BLOWER OUTLET ARE REQUIRED SEE GROUP 1 015 FOR PART NUMBER

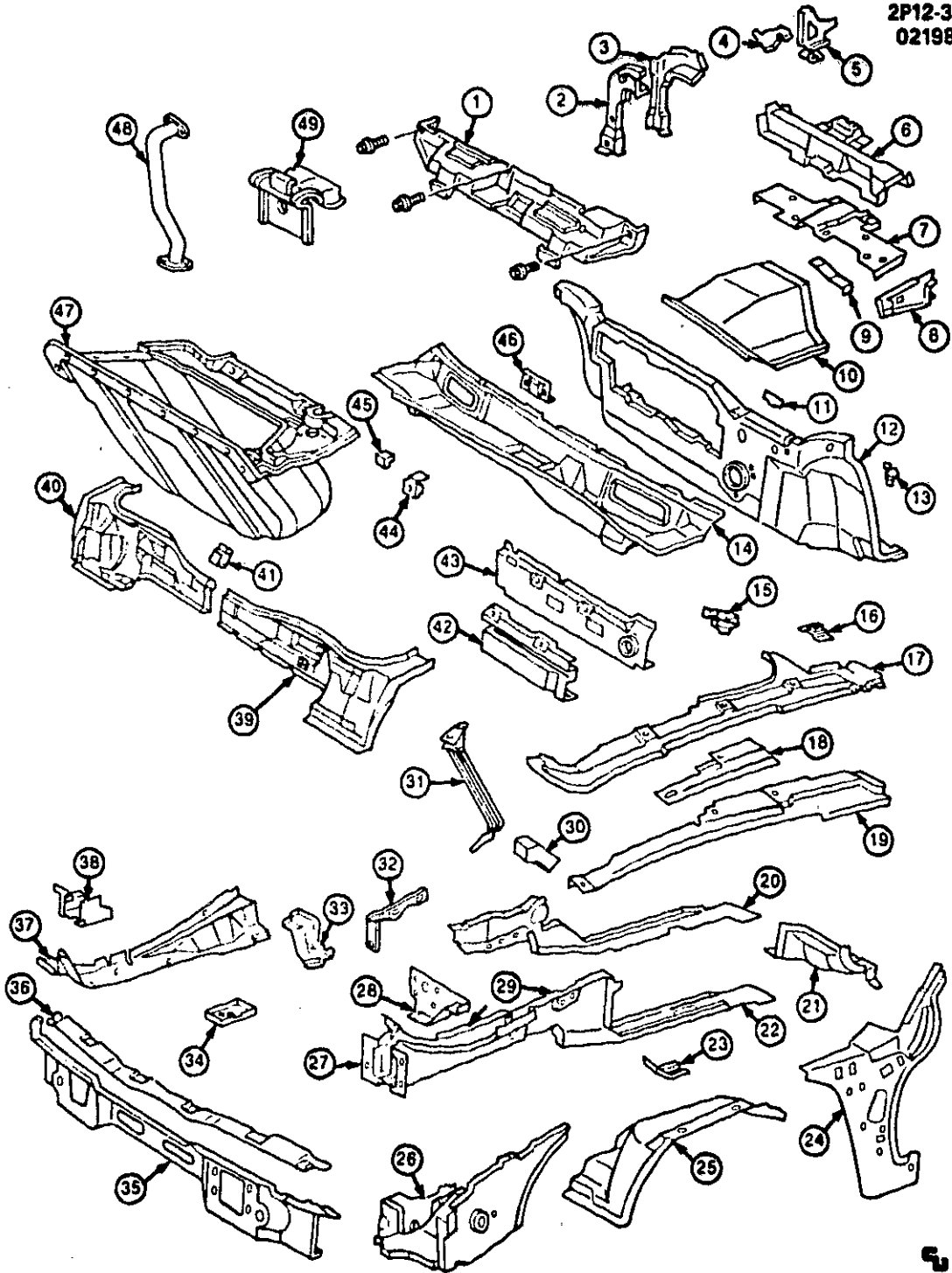

1988 P SHEET METAL/BODY PART 1-BODY FRONT

1.	B11	12.810	COVER, RF VENT GLS STOW (W/AD3)	20680013
2.		N.S.	SUPPORT, STRG COL SUPT BRKT	
3.	N18	6.758	SUPPORT, STRG COL UPR	7839279
4.	N19	6.760	BRACE, STRG COL SUPT BRKT	20314572
5.	N19	6.760	BRACE, STRG COL SUPT	20416366
6.	N18	6.758	BRACKET, STRG COL UPR	20566283
7.	N18	6.758	SUPPORT, STRG COL LWR	20564887
8.	N18	6.758	BRACKET, STRG COL SUPT LWR-RH	20599026
	N18	6.758	BRACKET, STRG COL SUPT LWR-LH	20810462
9.	N18	6.758	BRACE, WRG HARN BRKT	20563219
10.		N.S.	PANEL, FLR PAN TUN EXT FRT	
11.		N.S.	CLIP, RDO ANT CBL	
12.	B11	12.804	PANEL, DA	20815083
13.		N.S.	SUPPORT, DA PNL SOUND ABS	
14.		N.S.	PANEL, SHRD TOP VENT DUCT	
15.	N17	3.452	SUPPORT, ACCEL MT	20519461
16.	B16	12.940	BLOCK, QTR UPR PNL ATCH (I) 269(PART OF 17 & 35)	20338249
17.	N19	7.006	RAIL, SI UPR-RH (INCL 16 18,19)	12391170
	N19	7.006	RAIL, SI UPR-LH (INCL 16 18,19)	12391171
		N.S.	RAIL, SI UPR-RH (LESS BLK PLT REINF)	
		N.S.	RAIL, SI UPR-LH (LESS BLK PLT REINF)	
18.		N.S.	PLATE, UPR SI RL REINF RH (PART OF 17)	
		N.S.	PLATE, UPR SI RL REINF-LH (PART OF 17)	
19.	N19	7.006	REINFORCEMENT, UPR SI RL RH (PART OF 17)	
		N.S.	RAIL, UPR SI RL-LH (PART OF 17)	
20.		N.S.	RAIL, SI LWR RR INR (PART OF 29)	
21.	B19	12.986	REINFORCEMENT, DA PNL LWR OTR SI-RH	20307228
	B19	12.986	REINFORCEMENT, DA PNL LWR OTR SI-LH	20307227
22.		N.S.	RAIL, SI LWR RR OTR (PART OF 29)	
23.	N25	8.155	REINFORCEMENT, INR/OTR RR LWR SI RL RH (PART OF 29)	20314570
	N25	8.155	REINFORCEMENT, INR/OTR RR LWR SI RL LH (PART OF 29)	20314571
24.	B12	12.840	PANEL, H/PLR INR-RH	20636330
	B12	12.840	PANEL, H/PLR INR-LH	20636331
25.	N24	8.153	PANEL, W/H-RH	20635044
	N24	8.153	PANEL, W/H-LH	20635045
26.	N24	8.153	EXTENSION, W/H PNL RH	10119920
	N24	8.153	EXTENSION, W/H PNL-LH	10084335
27.	N19	7.006	RAIL, LWR SI-RH (PART OF 29)	20635026
	N19	7.006	RAIL, LWR SI-LH (PART OF 29)	10071777
28.	N20	7.009	EXTENSION, LWR RL RR TO DA-LH	20692105
29.	N19	7.006	RAIL, LWR-RH (INCL 20 22 23 27)	12391182
	N19	7.006	RAIL, LWR-LH (INCL 20 22 23 27)	12391183
30.	N19	7.006	REINFORCEMENT, OTR RR LWR-RH	20680010
	N19	7.006	REINFORCEMENT, OTR RR LWR-LH	20680011
31.	N23	8.015	SUPPORT, COMPT LID	20379368
32.	N23	8.015	HINGE, COMPT-RH	20594604
	N23	8.015	HINGE, COMPT-LH	20594605
33.	N20	7.009	EXTENSION, LWR RL RR TO DA-RH	20692104
34.	N20	7.242	REINFORCEMENT, SUSP-RH	10071792
	N20	7.242	REINFORCEMENT, SUSP-LH	10071793
35.	N16	1.263	PANEL, MT (INCL 18 & 36)	12391189
36.	N16	1.263	BAR, UPR TIE (PART OF 35)	
37.	N19	7.006	RAIL, SI LWR FRT UPR-RH	10071768
	N19	7.006	RAIL, SI LWR FRT UPR-LH	10071769
38.	N18	6.008	BRACKET, SUSP-RH	10071790
	N18	6.008	BRACKET, SUSP-LH	10071791
39.	N17	2.726	PANEL, COMPT & HDLP MT LH (INCL 41)	10074071
40.	N17	2.726	PANEL, COMPT & HDLP MT-RH	20601014
41.	N25	8.820	RETAINER, JACK HDL STOW ON LH PNL (PART OF 39)	20416326
42.		N.S.	REINFORCEMENT, BAR TORQ	
43.		N.S.	BAR, TORQ	
44.		N.S.	SUPPORT, OTR	
45.		N.S.	BRACKET, RF VENT WDO STOW CVR	
46.		N.S.	REINFORCEMENT, SHRD PNL AT LK	
47.	N26	8.160	POCKET, SPA WHL	10077315
48.	B11	12.804	HOSE, DRN SHRD TOP VENT DUCT-RH	20314576
	B11	12.804	HOSE, DRN SHRD TOP VENT DUCT-LH	20314577
49.	B12	12.811	RETAINER, RF VENT STOW (W/AD3)	20378691

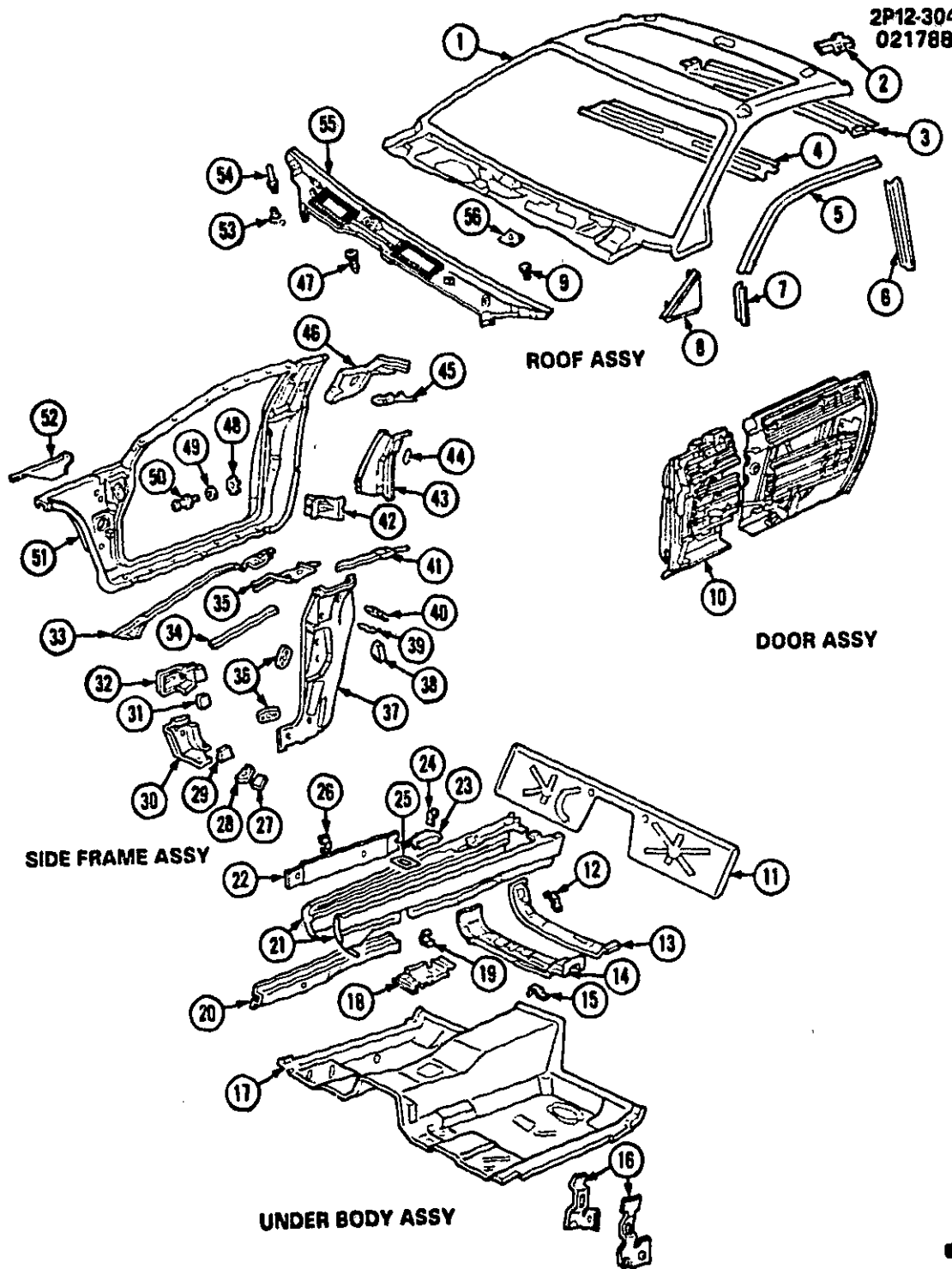

1988 P SHEET METAL/BODY PART 2-BODY-CENTER

1.	B11	12.810	PANEL, RF (STL)	20618555
2.		N.S.	REINFORCEMENT, LIFT OFF RF OPG OTR RR	
3.	B18	12.964	PANEL, BK WDO INR UPR	20881087
4.	B11	12.807	FRAME, W/S INR UPR (W/RF VENT)	20680079
5.	N28	10.721	RETAINER, W/S SI RF RL-RH	20320528
	N28	10.721	RETAINER, W/S SI RF RL-LH	20320527
6.	N28	10.721	RETAINER, W/STR BODY LK PLR-RH (INCL CLIP)	20320548
	N28	10.721	RETAINER, W/STR BODY LK PLR-LH (INCL CLIP)	20320549
	N28	10.685	CLIP, GDE WDO	20320530
7.	N28	10.695	RETAINER, W/STR H/PLR UPR-RH	20320564
	N28	10.695	RETAINER, W/STR H/PLR UPR-LH	20320565
8.	B11	12.807	FILLER, W/S FRM AT BELT-RH	20694740
	B11	12.807	FILLER, W/S FRM AT BELT-LH	20894741
9.	B10	12.800	FASTENER, SCRNR TOP VENT TO RF PNL CVR	20511451
10.	B12	12.895	PANEL, DR INR-RH (W/OTR REINF)	10118314
	B12	12.895	PANEL, DR INR-LH (W/OTR REINF)	10118315
11.		N.S.	PANEL, FLR PAN EXT RR LWR	
12.		N.S.	SUPPORT, HTR & A/C LINES FLR PAN	
13.		N.S.	REINFORCEMENT, FLR PAN AT ST ADJ RR	
14.		N.S.	REINFORCEMENT, FLR PAN AT ST ADJ FRT	
15.		N.S.	RETAINER, COOLANT HOSE CLAMP	
16.	D12	14.875	BRACKET, ST BELT ANC & HNGR STRP-RH (3 015)	10054894
	D12	14.875	BRACKET, ST BELT ANC & HNGR STRP-LH (3 015)	10054893
17.		N.S.	PAN, FLR	
18.		N.S.	SUPPORT, GEAR SHIFT	
19.		N.S.	SUPPORT, STRP FRT	
20.		N.S.	SUPPORT, REINF UPR	
21.		N.S.	REINFORCEMENT, FLR PAN UPR	
22.	B13	12.934	PANEL, RKR INR-RH (INCL 26)	20836328
	B13	12.934	PANEL, RKR INR-LH (INCL 26)	20836329
23.		N.S.	PLATE, JACKING ON FLR PAN	
24.	E5	15.100	RETAINER, TR OTR PNL INR	20348030
25.		N.S.	STRAP, REINF UPR	
26.		N.S.	SUPPORT, TR ON RKR INR (PART OF 22)	
27.		N.S.	PLATE, BFL INR FRT BODY HGE	
28.		N.S.	PLATE, BFL OTR BODY HGE	
29.		N.S.	PLATE, ANC UPR HGE (BODY SI)	
30.	B12	12.840	REINFORCEMENT, H/PLR AT LWR HGE-RH	20547852
	B12	12.840	REINFORCEMENT, H/PLR AT LWR HGE-LH	20547853
31.	N27	10.454	PLATE, ANC LWR HGE-RH (BODY SI)	20521324
	N27	10.454	PLATE, ANC LWR HGE-LH (BODY SI)	20521325
32.	B12	12.840	REINFORCEMENT, H/PLR AT UPR HGE-RH	20307354
	B12	12.840	REINFORCEMENT, H/PLR AT UPR HGE-LH	20307355
33.	B11	12.807	FRAME, W/S SI INR-RH	20815094
	B11	12.807	FRAME, W/S SI INR-LH	20479017
34.	B11	12.807	REINFORCEMENT, W/S SI FRM-RH	20330794
	B11	12.807	REINFORCEMENT, W/S SI FRM-LH	20330795
35.	B11	12.807	REINFORCEMENT, W/S INR UPR COR-RH	20692086
	B11	12.807	REINFORCEMENT, W/S INR UPR COR-LH	20692087
36.		N.S.	PLATE, ANC ST BELT	
37.	D12	14.731	PANEL, BODY LK PLR INR LWR-RH (W/O MTG SPKR)	20692080
	D12	14.731	PANEL, BODY LK PLR INR LWR-LH (W/MTG SPKR)	20692081
38.	B15	12.942	REINFORCEMENT, BODY LK PLR INR LWR-RH	20367358
	B15	12.942	REINFORCEMENT, BODY LK PLR INR LWR-LH	20367359
39.		N.S.	PLATE, BFL BODY LK PLR LWR OTR	
40.		N.S.	PLATE, BFL BODY LK PLR LWR INR	
41.	B18	12.957	RAIL, RF INR SI-RH	20307362
	B18	12.957	RAIL, RF INR SI-LH	20307363
42.	B15	12.942	REINFORCEMENT, BODY LK AT LK STKR-RH	20334408
	B15	12.942	REINFORCEMENT, BODY LK AT LK STKR-LH	20334409
43.	B15	12.942	REINFORCEMENT, BODY LK PLR UPR-RH	20692082
	B15	12.942	REINFORCEMENT, BODY LK PLR UPR-LH	20692083
44.		N.S.	PLATE, CTR PLR UPR & SHLDR BELT ANC	
45.	B15	12.942	EXTENSION, REINF BODY LK PLR TO FRM BODY-RH	20325538
	B15	12.942	EXTENSION, REINF BODY LK PLR TO FRM BODY-LH	20325539
46.	D12	14.731	PANEL, BODY LK PLR INR UPR-RH	20563186
	D12	14.731	PANEL, BODY LK PLR INR UPR-LH	20563187
47.		8.977	SCREW, RD LRG WA HD C/R M4 2X1 41X25PEOR(AR)	11505650
48.	N28	10.571	PLATE, LK STKR ANC	20277001
49.		8.929	WASHER, FLAT (M11X40X3)	11500367
50.	N27	10.569	STRIKER, LK (INCL WA)	20464563
		8.929	WASHER, FLAT (M13X45X1 5)	1280895
51.	N19	7.008	FRAME, BODY SI-RH	10074046

51.	N19	7.008	FRAME, BODY SILH	20894755
52.	N19	7.008	REINFORCEMENT, BODY H/PLR OTR PNL UPR-RH	20429018
	N19	7.008	REINFORCEMENT, BODY H/PLR OTR PNL UPR-LH	20429019
53.	N23	8.083	SPRING, HOOD POP-UP	20472201
54.	B13	12.934	RIVET, PNL W/H LNR FRT TO PNL (8 133)	20433028
55.	B10	12.800	SCREEN, SHRD TOP VENT	10074271
56.		N.S.	REINFORCEMENT, W/S WIPER TRANS MTG	

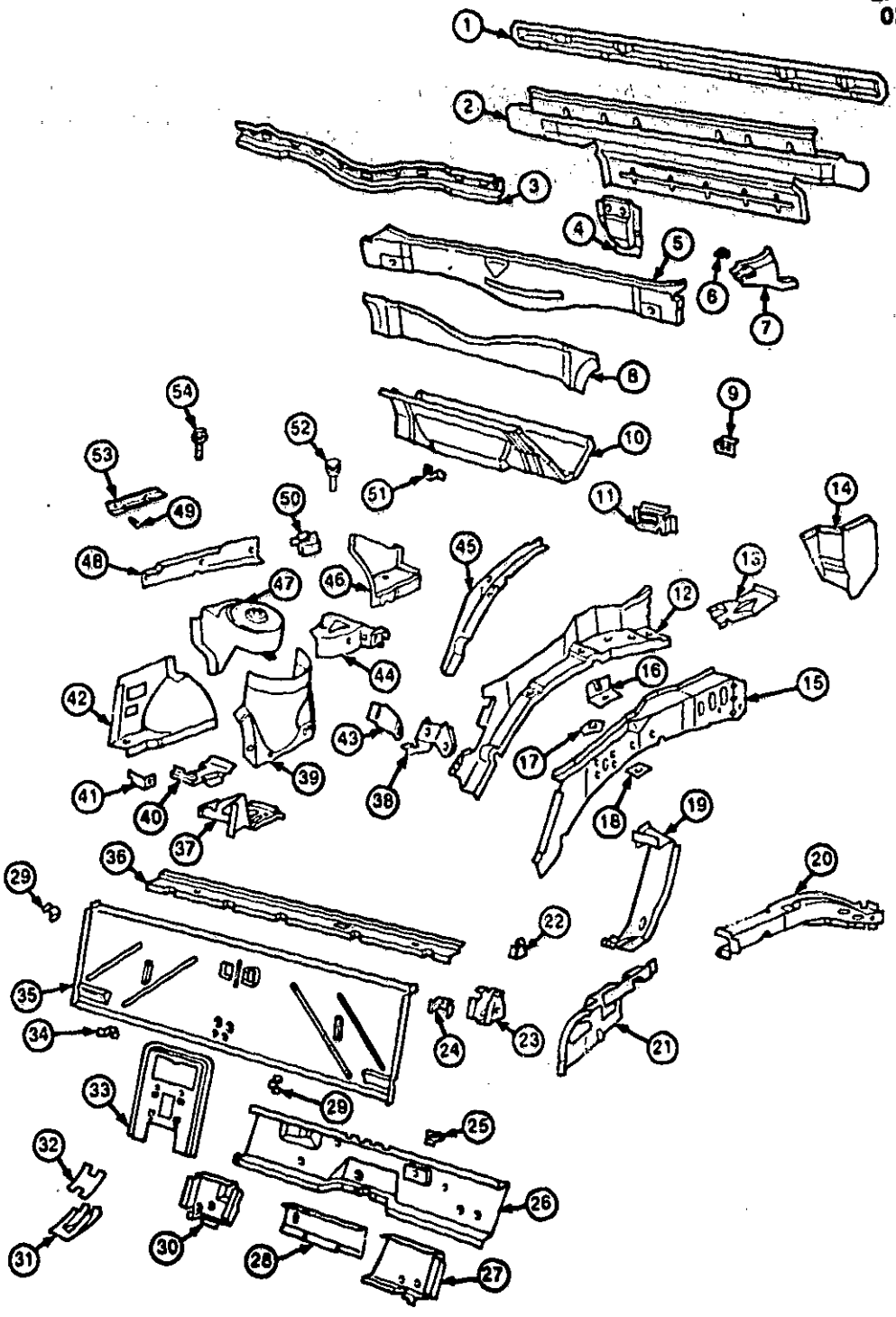



1988 P SHEET METAL/BODY PART 3-BODY-REAR

1.		N.S.	REINFORCEMENT, R/END PNL UPR (PART OF 2)	
2.	B18	12.986	PANEL, R/END (INR) INCL 1 4 6)	12391172
3.	B19	12.986	BAR, BODY UPR RR CR	20622160
4.		N.S.	SUPPORT, RR COMPT L/WDO LK STKR (PART OF 2)	
5.	B16	12.944	REINFORCEMENT, BODY UPR RR CR BAR	20680119
6.	B16	12.940	BLOCK, QTR UPR PNL ATCH (1 269)(PART OF 2 & 20)	20338249
7.	N19	7.006	EXTENSION, SI RL QTR UPR RR-RH	10078226
	N19	7.006	EXTENSION, SI RL QTR UPR RR-LH	20322899
8.	B16	12.944	PANEL, MTR COMPT RR	10078227
9.	B7	12.181	BRACKET, ENG COMPT UPR SI GRL-RH (P37)	10107814
	B7	12.181	BRACKET, ENG COMPT UPR SI GRL-LH (P37)	10107815
	B7	12.181	BRACKET, ENG COMPT UPR SI GRL RH (P97)	10077372
	B7	12.181	BRACKET, ENG COMPT UPR SI GRL LH (P97)	10077373
10.	B7	12.181	PANEL, RR COMPT LWR	20305670
11.	N18	3.885	SUPPORT, CR/CONT (MT ON RR CR BAR REINF)	20532722
12.	B19	12.986	RAIL, ENG COMPT INR SI-RH (INCL 16 18 31 32 38 43 45)	12391178
	B19	12.986	RAIL, ENG COMPT INR SI-LH (INCL 16 18 31 32 38 43 45)	12391177
13.	B18	12.981	PANEL, RR COMPT UPR-RH	20320568
	B18	12.981	PANEL, RR COMPT UPR-LH	20320569
14.	B16	12.944	PANEL, RR COMPT SI-RH	20320570
	B16	12.944	PANEL, RR COMPT SI-LH	20320571
15.	N19	7.006	RAIL, ENG COMPT OTR SI-RH	10125872
	N19	7.006	RAIL, ENG COMPT OTR SI-LH	10071795
16.	B19	12.986	REINFORCEMENT, MTR COMPT LWR RL AT RR CRADLE MT RH (PART OF 12)	20314528
	B19	12.986	REINFORCEMENT, MTR COMPT LWR RL AT RR CRADLE MT LH (PART OF 12)	20314529
17.	N15	0.029	RETAINER, MTR COMPT CRADLE MT RR NUT RH (PART OF 12)	20341732
	N15	0.029	RETAINER, MTR COMPT CRADLE MT RR NUT-LH (PART OF 12)	20341733
18.	N15	0.029	PLATE, RR CRADLE MT TO TAIL LWR INR (PART OF 12)	20363478
19.	B19	12.986	EXTENSION, ENG COMPT OTR SI RL RH	10071819
	B19	12.986	EXTENSION, ENG COMPT OTR SI RL-LH	20534623
20.	B19	12.986	RAIL, MTR COMPT SI UPR-RH (INCL 6 & 48)	12391174
	B19	12.986	RAIL, MTR COMPT SI UPR-LH (INCL 6 & 48)	12391173
		N.S.	RAIL, QTR SI UPR-RH (LESS BLK REINF)	
21.	B16	12.944	PANEL, RR W/H FRT INR-LH	20492799
		N.S.	BRACKET, TORQ ROD RET (PART OF 23)	
23.	B9	12.184	SUPPORT, RR COMPT LID AT HGE-RH (INCL 22)	20513475
	B9	12.184	SUPPORT, RR COMPT LID AT HGE-LH (INCL 22)	20638949
24.		N.S.	SUPPORT, MTR COMPT MOD ON EXT FLR PAN RR UPR	
25.		N.S.	BRACKET, CT/LTC CONVR HT SHLD	
26.		N.S.	BAR, TORQ RR	
27.		N.S.	REINFORCEMENT, FLR PNL RR CR BAR LH	
28.		N.S.	REINFORCEMENT, RR TORQ BAR CVR	
29.	B18	12.981	RETAINER, MTR COMPT INSL	20346032
30.		N.S.	REINFORCEMENT, FLR PNL RR CR BAR RH	
31.	B19	12.986	EXTENSION, MTR COMPT LWR RL (PART OF 12)	20314632
32.		N.S.	REINFORCEMENT, ENG COMPT INR SI RL EXT (PART OF 12)	
33.		N.S.	SUPPORT, PNL FLR PAN EXT UPR RR	
34.		N.S.	BRACKET, HTR INL PIPE	
35.		N.S.	PANEL, BODY F/ST BK	
36.		N.S.	ABSORBER, BODY F/ST BK PNL SOUND	
37.	N16	2.333	TRAY, BAT	10071787
38.		N.S.	SUPPORT, MTR COMPT FRT CRADLE (PART OF 12)	
39.	B16	12.944	PANEL, RR W/H CTR INR-RH	10071774
	B16	12.944	PANEL, RR W/H CTR INR-LH	10071775
40.	N16	2.333	SUPPORT, BAT HOLDN	20489129
41.		N.S.	SUPPORT, FUEL LINE & HT SHLD	
42.	B16	12.944	PANEL, RR W/H FRT INR RH	20880575
43.	B19	12.986	BRACE, DR TRAIN & RR SUSP FRM BRKT RH (PART OF 12)	20593140
	B19	12.986	BRACE, DR TRAIN & RR SUSP FRM BRKT LH (PART OF 12)	20567029
44.	N15	0.029	SUPPORT, ENG MT STRUT	20830416
45.	B19	12.986	REINFORCEMENT, ENG COMPT INR SI RI RH (PART OF 12)	10092161
	B19	12.986	REINFORCEMENT, ENG COMPT INR SI RL LH (PART OF 12)	10103881
46.	B16	12.944	PANEL, RR W/H RR INR-RH	20307358
	B16	12.944	PANEL, RR W/H RR INR-LH	20307359
47.	N20	7.395	HOUSING, RR SUSP STRUT UPR RH	20872892
	N20	7.395	HOUSING, RR SUSP STRUT UPR-LH	20872893
48.		N.S.	REINFORCEMENT, QTR UPR SI RL-RH (PART OF 20)	
		N.S.	REINFORCEMENT, QTR UPR SI RL-LH (PART OF 20)	
49.	B7	12.181	RETAINER, ENG COMPT UPR SI GRL OPG PNL EXT (P37)	20513451
50.		N.S.	BRACKET, ENG WRG HARN J/BLK	
51.	N18	3.706	RETAINER, HT SHLD AT MUFF ON RR COMPT LWR	20346033

52	89	12.184	BUMPER, MTR COMPT CVR SI (P37)(PART OF 53X12 810)	20465423
	815	12.940	BUMPER, ENG COMPT UPR SI GRL (P97)(PART OF 53X12 810)	20465423
53.	87	12.181	EXTENSION, MTR COMPT CVR SI-RH (INCL 52)	20867568
	87	12.181	EXTENSION, MTR COMPT CVR SI LH (INCL 52)	20867569
54.		8.977	SCREW, PAN HD TORX W. FL WA TAP (M6 3X1 81X30) P2OR	11507094

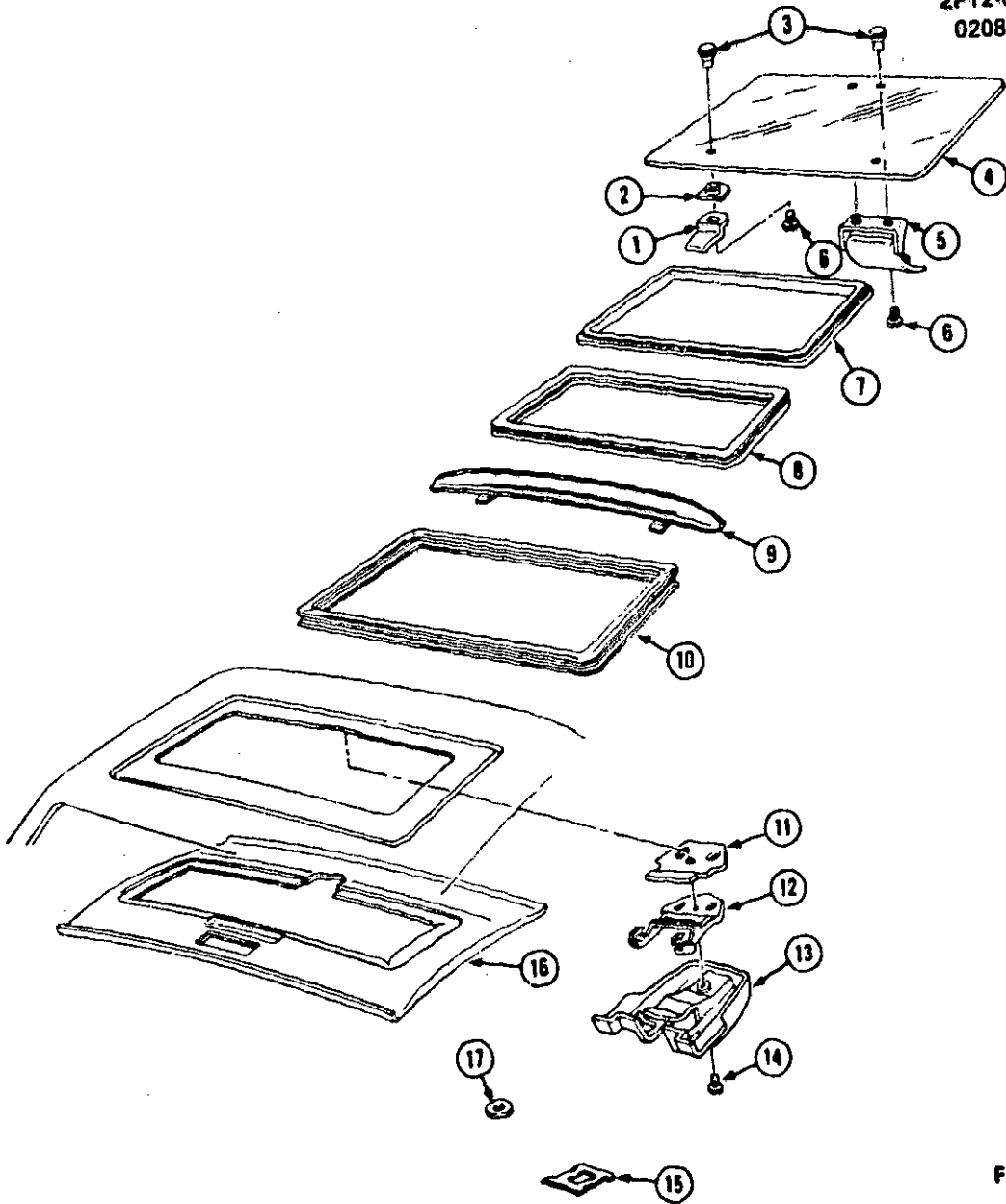
2P12-014
020889



FBS-2208

2P12-014

1984-1988 P ROOF HARDWARE/VISTA VENT (AD3)

NOTE FBS-2208

1.	B12	12.811	HINGE, RF VENT (BLACK)	20424246
2.	B12	12.811	BUSHING, RF VENT HGE	20362045
3.	B12	12.811	NUT, RF VENT HGE	20564430
4.	B12	12.811	GLASS, VENT RF OPG (GREY)	20326111
5.	B11	12.809	HANDLE, RF VISTA VENT GLS HALF	10056530
6.	B12	12.811	SCREW, VISTA VENT HDL RF VENT FRT TO GLS	20561900
7.	D10	14.650	LACE, FIN RF VENT OPG TR (LT SLATEGRAY 13B-C-DX1984-85X*1)	20525012
	D10	14.650	LACE, FIN RF VENT OPG TR (MED DK GRAY 82B-D1822K1986-88X*1)	10071562
8.	D10	14.640	RETAINER, HDLNG AT VISTA VENT	20338260
9.	B18	12.971	DEFLECTOR, AIR RF VENT (BLACK)	20448443
10.	B11	12.810	WEATHERSTRIP, LIFT OFF PNL COMPL	20528472
11.	B11	12.809	SPACER, VISTA RF VENT HDL (BLACK)	20510001
12.	B11	12.810	BUTTON, PUSH RF VISTA VENT BODY HALF	20449748
13.	B12	12.811	ESCUTCHEON, RF VISTA VENT	20680159
14.		8.977	SCREW, RD WA HD C/R TAP (M4 2X1 41X20)BLK ORG	20378000
15.	D10	14.640	RETAINER, HDLNG FSTN	20310513
16.		N.S.	PANEL, TR FIN HDLNG (LT SLATEGRAY 13B-C DX1984X*1)	
		N.S.	PANEL, TR FIN HDLNG (LT SLATEGRAY 13B-DX1985X*1)	
	D10	14.640	PANEL, TR FIN HDLNG (MED DK GRAY 82B-D1-2K1986 88X*1)	20605467
17.	B11	12.810	BUSHING, RF O/P V-VENT HGE (LAT TO GLS)	20566100

NOTE 1 SEE PARTS CATALOG FOR ADDITIONAL COLORS AND APPLICATIONS

2P12-010
031485

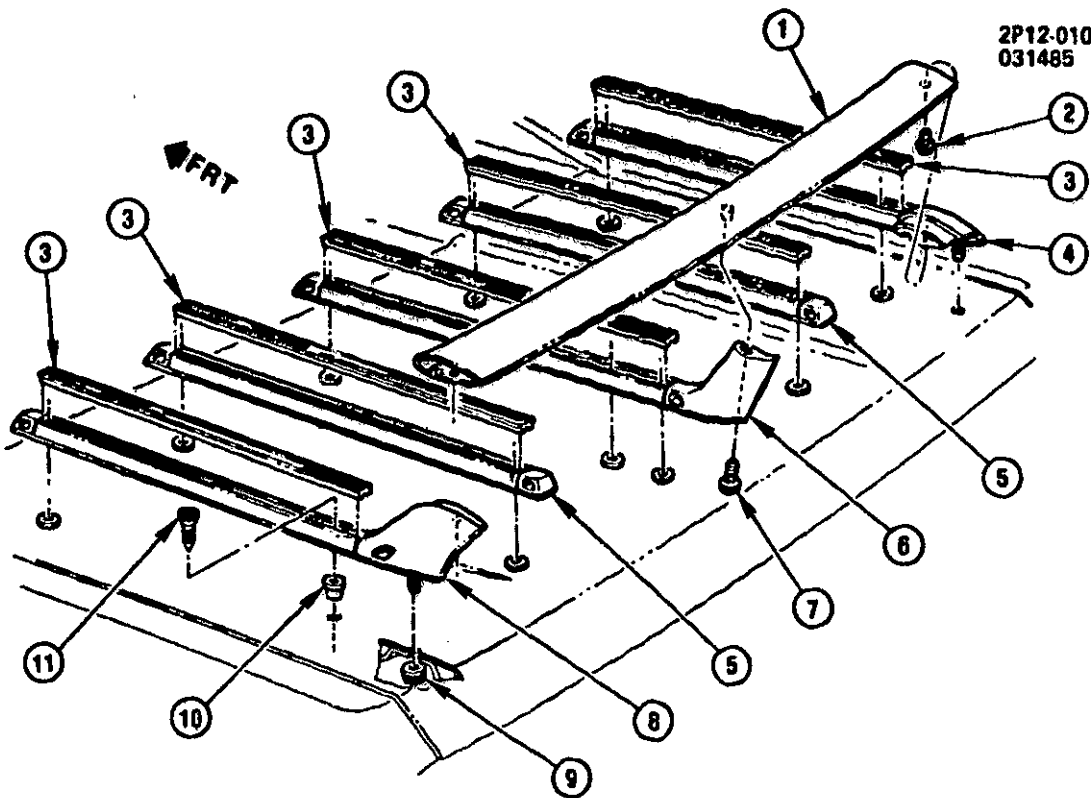

2P12-010

1984-1988 P LUGGAGE CARRIER/REAR COMPARTMENT (V58)

1.	B12	12.815	WING, CARR (1984-85)(1986-88 P36 W V56)	10028125
	B12	12.815	RAIL, LUG CARR RR (1986-88 P97 W V56)	10040800
2.		8.977	SCREW, RD WA C R TAP (M4 2X1 41X12 HILO)	11509231
3.	B12	12.815	PAD, SLAT OTR & CTR(*1)	10023885
4.	B12	12.815	SLAT, OTR CARR-RH (1984)	10023875
5.	B12	12.815	SLAT, INR CARR	10023889
6.	B12	12.815	SLAT, CTR CARR	10023874
7.		8.913	SCREW, PAN RD HD (M5 X 8 X 16)	11508515
8.	B12	12.815	SLAT, OTR CARR-LH	10023876
9.		8.917	NUT, HWH (M6X1X5 5) 9 PEO	11508388
10.	B12	12.815	NUT, HWH (M6X1)	14002811
11.		8.909	SCREW, OV HD C S C R (M6 X 1 X 25 PEOR)	11508516

NOTE 1 CUT TO SIZE

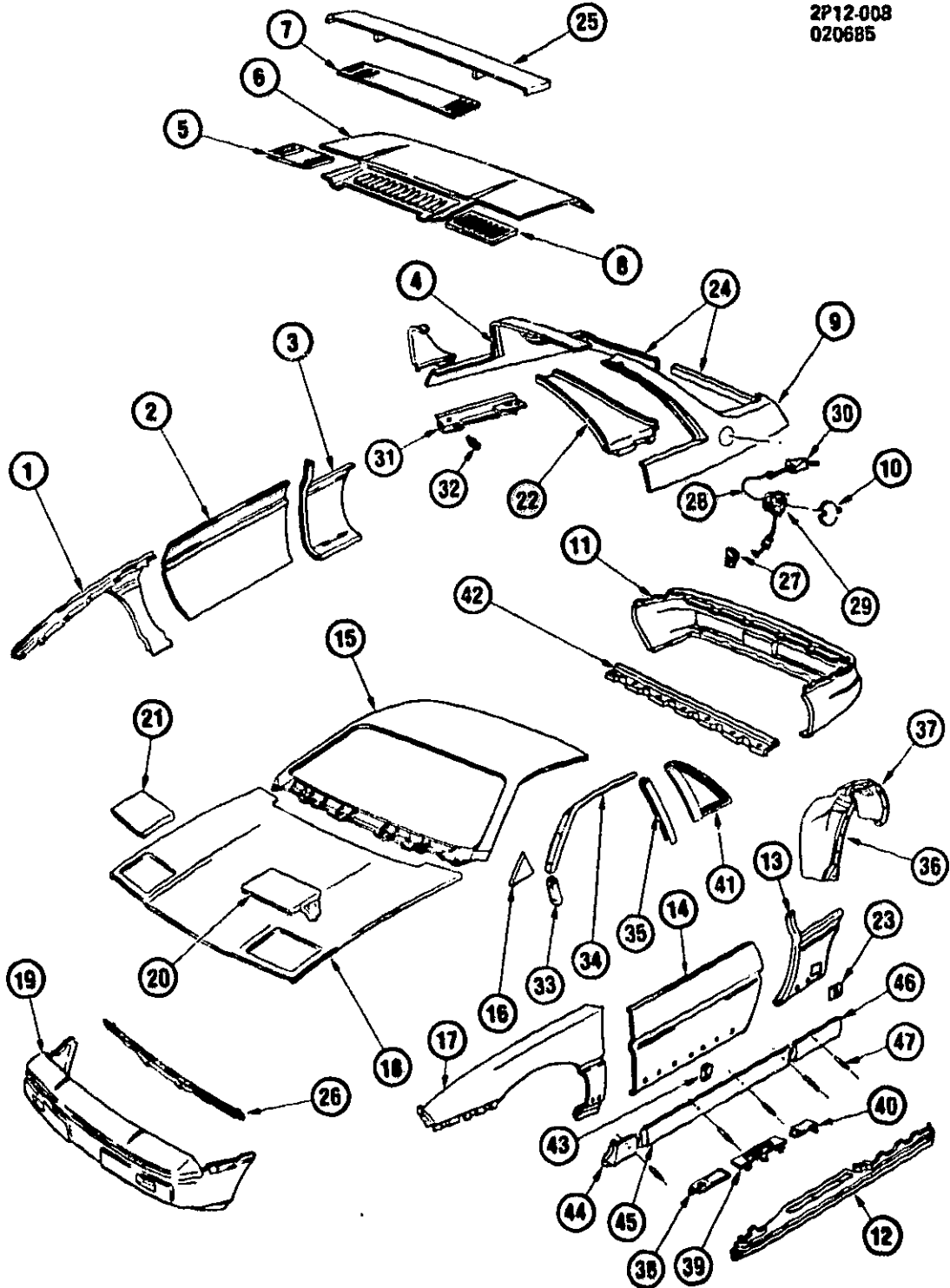

1984 P BODY PLASTIC PARTS/EXTERIOR

1.	N23	8.130	PANEL, F/FDR-RH(1984X*4)	10077314
2.	B12	12.895	PANEL, F/D OTR-RH(*1)	20590904
	B12	12.895	PANEL, F/D OTR-RH(*2)	20882346
	B6	12.118	FASTENER, F/D TO REINF AT BELT	20429451
3.	B15	12.940	PANEL, Q/OTR LWR-RH	10077316
	B13	12.934	RIVET, PNL TO BODY(M6 61X57 1 ALUM)	20375100
4.	B15	12.940	PANEL, Q/OTR UPR-RH(*4)	10077085
5.	B7	12.181	PANEL, RR COMPT MTR CVR GRL SI-RH	20505092
6.	B7	12.181	PANEL, RR COMPT LID	20483183
7.	B7	12.181	PANEL, RR COMPT MTR CVR GRL CTR	20382026
8.	B7	12.181	PANEL, RR COMPT MTR CVR GRL SI-LH	20505093
9.	B15	12.940	PANEL, Q/OTR UPR-LH(*4)	10077086
10.	B17	12.945	DOOR, FUEL FILLER	20527000
11.	N21	7.831	FASCIA, RR BPR (EXC Y82)	10032433
12.	B13	12.934	PANEL, RKR OTR CVR-LH(*3)	20481605
	B13	12.934	PANEL, RKR OTR FIN-RH (EXC Y82X*3)	20481664
	B13	12.934	RIVET, PNL TO FRT FDR (M6 61X57 1 ALUM)	20375100
	B13	12.934	RETAINER, RKR OTR CVR (1 276)	20884092
13.	B15	12.940	PANEL, Q/OTR LWR LH (EXC Y82)	20592099
	B13	12.934	RIVET, RR Q/LWR BDY SI FRM (M6 61X57 1 ALUM)	20375100
14.	B12	12.895	PANEL, F/D OTR-LH(*1)	20590905
	B12	12.895	PANEL, F/D OTR-LH(*2)	20682347
	B6	12.118	RIVET, F/D (8 133X*2)	20433026
	B6	12.118	FASTENER, F/D TO REINF AT BELT	20429451
15.	B11	12.810	PANEL, ROOF (PLSTC/EXC AD3)	20302390
		8.900	BOLT, HEX W/CON SPR WA (M6X1X25X9 8 PZOR)	
16.	B11	12.807	FILLER, W/S FRM AT BELT-LH	20348399
	B11	12.807	FILLER, W/S FRM AT BELT RH	20348398
17.	N23	8.130	PANEL, F/FDR-LH(1984X*4)	20572975
18.	N23	8.000	HOOD	20618584
19.	N21	7.831	FASCIA, FRT BPR (EXC Y82)	10032432
	N21	7.831	FASCIA, FRT BPR-W/Y82	10042562
20.	N17	2.770	PANEL, HDLP CVR-LH	20302393
21.	N17	2.770	PANEL, HDLP CVR-RH	20302392
22.	B15	12.940	FILLER, R/WDO TO OTR OTR UPR SI RH	20880556
	B15	12.940	FILLER, R/WDO TO OTR OTR UPR SI-LH	20880557
23.	B15	12.940	GRILLE, Q/LWR AIR INTAKE	20476888
24.	B15	12.940	PANEL, Q/OTR UPR	10084333
25.	B7	12.181	SPOILER, RR COMPT LID AIR (D80)	10077408
26.	N21	7.831	REINFORCEMENT, FRT FASCIA	10041875
	N21	7.831	REINFORCEMENT, FRT BPR FASCIA LWR DEF W-Y82	10037000
27.	B17	12.945	LATCH, FUEL FILLER DR REMOTE	20509500
28.	B17	12.945	CABLE, REM REL FUEL FIL DR	10056571
29.	B17	12.945	POCKET, FUEL TANK FILLER	20326093
30.	B17	12.945	HANDLE, REM REL FUEL FIL DR	20378261
31.	B7	12.181	EXTENSION, M/C CVR SI-RH	20867568
	B7	12.181	EXTENSION, M/C CVR SI-LH	20867569
32.	B7	12.181	RETAINER, RR COMPT MTR CVR SI	20351044
		8.977	SCREW, OV HD C/R CB (M4 2X1 41X13)	
33.	N28	10.695	RETAINER, W/STRP F/D H/PLR UPR-RH	20320564
	N28	10.695	RETAINER, W/STRP F/D H/PLR UPR-LH	20320565
		8.977	SCREW, RD HD C/R TAP W/WA FACE (#8 18X 4")	
34.	N28	10.721	RETAINER, W/S SI RF RAIL RH	20320526
	N28	10.721	RETAINER, W/S SI RF RAIL LH	20320527
		8.977	SCREW, RD HD C/R TAP W/WA FACE (#8 18X 4")	
35.	N28	10.721	RETAINER, W/STR BODY LK PLR-RH	20320548
	N28	10.721	RETAINER, W/STR BODY LK PLR-LH	20320549
		8.977	SCREW, RD WA HD C/R TAP (M4 2X1 41X30)	
36.	B16	12.944	PANEL, RR W/H LNR FRT RH (EXC Y82)	10077484
	B16	12.944	PANEL, RR W/H LNR FRT LH (EXC Y82)	10077485
	B16	12.944	RETAINER, W/H INR PNL TO FRAME (1 276)	20884092
37.	B16	12.944	PANEL, RR W/H LNR RR-RH (EXC Y82)	20521260
	B16	12.944	PANEL, RR W/H LNR RR-LH (EXC Y82)	20424241
	B16	12.944	RETAINER, W/H LNR (1 276)	20884092
38.	B13	12.934	PLATE, EMBLEM RKR CVR "FISHER COACH"	
39.	B13	12.934	PLATE, RKR OTR CVR "PONTIAC"	
40.	B13	12.934	PLATE, RKR OTR CVR	20397143
41.	B15	12.942	PANEL, APLQ Q/OTR UPR-RH	20532726
	B15	12.942	PANEL, APLQ Q/OTR UPR-LH	20532727
	B15	12.942	PANEL, APLQ Q/OTR UPR-W/VV9-RH	20484520
	B15	12.942	PANEL, APLQ Q/OTR UPR-W/VV9-RH	20484521
42.	N21	7.831	SUPPORT, RR BPR FASCIA	10020479
43.	N.S.		CLIP, EXTENSION	

43.	B13	12.934	CLIP, RKR CVR EXT TO DR PNL	20550151
44.	B13	12.934	EXTENSION, RKR CVR PNL TO Q-OTR PNL-RH (Y82)	20479376
	B13	12.934	EXTENSION, RKR CVR PNL TO Q-OTR PNL LH (Y82)	20479377
45.		N.S.	EXTENSION, RKR CVR PNL TO DR OTR PNL-RH (Y82)	
		N.S.	EXTENSION, RKR CVR PNL TO DR OTR PNL LH (Y82)	
46.		N.S.	EXTENSION, RKR CVR PNL TO Q-OTR PNL-RH (Y82)	
		N.S.	EXTENSION, RKR CVR PNL TO Q-OTR PNL LH (Y82)	
47.	B13	12.934	RETAINER, RKR OTR CVR (1 276)	20664092

NOTE 1 1ST DESIGN HAS PUSH IN FASTENER FOR UPPER ATTACHMENT FASTENER IS 12 118.

20429451 (3) USED

NOTE 2 2ND DESIGN HAS HANG ON RETAINER FOR UPPER ATTACHMENT

NOTE 3 ORIGINAL PART HAS 2 HOLE RETENTION OF NAME PLATE WHEREAS REPLACING PART HAS 3

HOLES

NOTE 4 PAINT AS REQUIRED

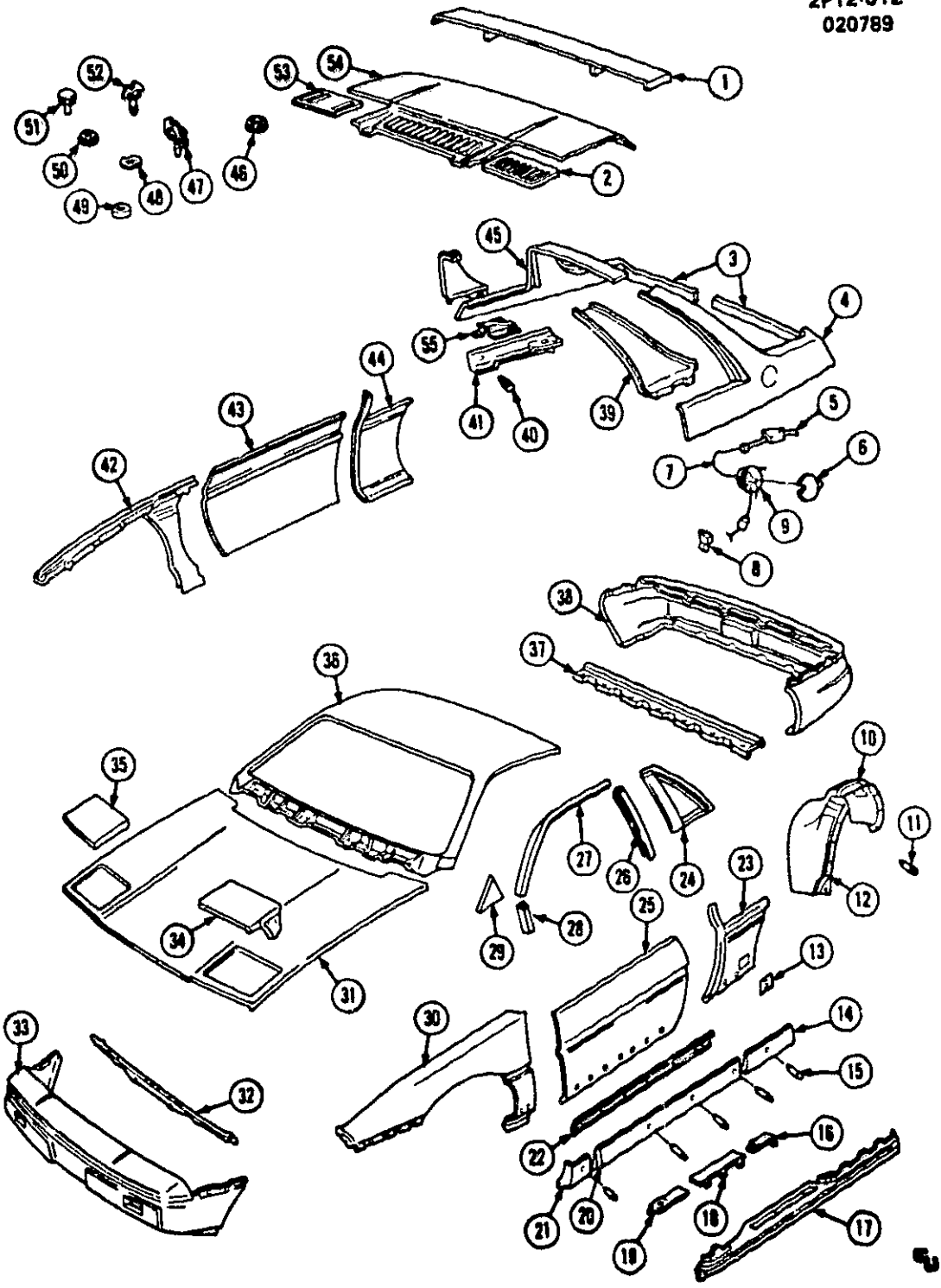

1985-1988 P37 BODY PLASTIC PARTS/EXTERIOR

1.	B7	12.181	SPOILER, RR COMPT LID AIR	10077408
2.	B7	12.181	PANEL, RR COMPI MTR CVR GRL SI-LH(*1)	10054681
3.	B16	12.940	PANEL, QTR OTR UPR (COMPLX INCL 4 45)	10084333
4.	B15	12.940	PANEL, QTR OTR UPR LH (1985-86)(PART OF 3)	10077086
	B15	12.940	PANEL, QTR OTR UPR-LH (1987-88)(PART OF 3)	10077066
5.	B17	12.945	HANDLE, REM REL FUEL FIL DR	20378261
6.	B17	12.945	DOOR, FUEL FIL	20527000
7.	B17	12.945	CABLE, REM REL FUEL FIL DR	10056571
8.	B17	12.945	LATCH, FUEL FIL DR REM	20509500
9.	B17	12.945	POCKET, F/TNK FIL	20326093
10.	B16	12.944	PANEL, RR W/H LNR RR-RH (W/B97 1985 87)(W/W69 1986)	20511208
	B16	12.944	PANEL, RR W/H LNR RR-LH (W/B97 1985 87)(W/W69 1986)	20511209
	B16	12.944	PANEL, RR W/H LNR RR (EXC B97 1985)(EXC W69 1986)	20521260
	B16	12.944	PANEL, RR W/H LNR RR-LH (EXC W69 1986)	10077485
	B16	12.944	PANEL, RR W/H LNR RR-RH (EXC B97 1987-88)	10077488
	B16	12.944	PANEL, RR W/H LNR RR-LH (EXC B97 1987-88)	10077489
11.	B16	12.944	RETAINER, W/H LNR (PUSH-IN)(1 276)	20864092
	B13	12.934	RIVET, PNL W/H LNR FRT TO PNL RR (8 13?)	20433026
12.	B16	12.944	PANEL, RR W/H LNR FRT RH	10077484
	B16	12.944	PANEL, RR W/H LNR FRT LH	10077485
13.	B15	12.940	GRILLE, QTR OTR LWR INT	20476886
14.	B13	12.934	PANEL, QTR OTR LWR-RH (W/W69)	10074292
	B13	12.934	PANEL, QTR OTR LWR-LH (W/W69 1986-87)	10074293
	B13	12.934	PANEL, QTR OTR LWR-LH (W/W69 1988)(*3)	10074293
15.	B6	12.116	RIVET, RKR CVR PNL EXT DR QTR LWR PNL (PUSH-IN)(1984 85)(8 13?)	20433026
16.	B13	12.934	PLATE, RKR OTR CVR (BLACK)	20397143
17.	B13	12.934	PANEL, RKR OTR CVR-RH (W/WU2 1985)(W/W69 1986-87)	10074286
	B13	12.934	PANEL, RKR OTR CVR-LH (W/WU2 1985)(W/W69 1986-87)	10074287
	B13	12.934	PANEL, RKR OTR FIN-RH (3 HOLES)(EXC WU2 1985)(EXC W69 1986)(EXC W69, B97 1987)(1988)	20461664
	B13	12.934	PANEL, RKR OTR CVR-LH (3 HOLES)(EXC WU2 1985)(EXC W69 1986)(EXC W69 B97 1987)(1988)	20481665
18.	B13	12.934	PLATE, NA RKR OTR CVR "FIERO" (LT SLATE GRAY 13)(3-STUDS)(1985)(*4)	20488451
	B13	12.934	PLATE, RKR OTR PNL (BLACK)(*5)	20635057
19.	B13	12.934	PLATE, RKR CVR "FISHER BODY" (LT SLATE GRAY-13)(1985)	20488424
	B13	12.934	PLATE, RKR CVR "FISHER BODY" (MED DOESKIN-64)(1985)	20488425
20.	B13	12.934	PANEL, F/D OTR LWR-RH (WU2 1985)(W69 1986-88)	10074290
	B13	12.934	PANEL, F/D OTR LWR-LH (W/WU2 1985)	10074291
	B13	12.934	PANEL, F/D OTR LWR-LH (W/W69)	10074291
21.	N23	8.130	PANEL, F/FDR LWR RR-RH (W/W69 1986-88)	10074288
	N23	8.130	PANEL, F/FDR LWR RR-LH (W/W69)	10074289
22.	B13	12.934	SUPPORT, F/D OTR LWR PNL (W/B97 1985 1987 88)(W/W69 1986 87)	20609210
23.	B15	12.940	PANEL, QTR OTR LWR LH	20592099
24.	B15	12.942	APPLIQUE, QTR UPR-RH (EXC BY 1 B57 1985)(EXC B57 1986 87)(1988)	20628358
	B15	12.942	APPLIQUE, QTR UPR-LH (EXC BY 1 B57 1985)(EXC B57 1986 87)(1988)	20628359
	B15	12.942	APPLIQUE, QTR UPR-RH (W B57 1985 87)	20628360
	B15	12.942	APPLIQUE, QTR UPR-LH (W/B57 1985-87)	20628361
	B15	12.942	PANEL, APLO QTR OTR UPRIGT(1985)	20628362
25.	B12	12.895	PANEL, F/D QTR-LH	20682347
26.	N28	10.721	RETAINER, W/STR BODY LK PLR-RH	20320548
	N28	10.721	RETAINER, W/STR BODY LK PLR-LH	20320549
		8.977	SCREW, RD WA HD C/R TAP (M4 2X1 41X20) BLK ORG	20378000
27.	N28	10.721	RETAINER, W/S SI RF RL-RH (INCL CLIP)	20320526
	N28	10.721	RETAINER, W/S SI RF RL-LH (INCL CLIP)	20320527
	N28	10.685	CLIP, GDE F/D WDO	20320530
28.	N28	10.695	RETAINER, W/STR F/D H/PLR UPR-RH	20320564
	N28	10.695	RETAINER, W/STR F/D H/P, R UPR-LH	20320565
		8.977	SCREW, LG WA HD C/R TAP (M4 2X1 41X8)	11503266
29.	B11	12.807	FILLER, W/S FRM AT BELT RH (1985)	20348388
	B11	12.807	FILLER, W/S FRM AT BELT LH (1985)	20348389
	B11	12.807	FILLER, W/S FRM AT BELT RH (1986 88)	20694740
	B11	12.807	FILLER, W/S FRM AT BELT LH (1986-88)	20694741
30.	N23	8.130	PANEL, FRT FDR-LH (DRILL AS REQD)	20572975
31.	N23	8.000	HOOD	20816564
32.	N21	7.631	REINFORCEMENT, FRT BPR FASCIA	10041875
33.	N21	7.631	FASCIA, FRT BPR (W/WU2 1985)(W/W69 1986 87)(*3)	10042662
	N21	7.631	FASCIA, FRT BPR (EXC WU2 1985)(EXC W69 1986)(*3)	10032432
	N21	7.631	FASCIA, FRT BPR (EXC W69 1987)(1988)	10055040
34.	N17	2.770	PANEL, HDLP CVR-LH	20302393
35.	N17	2.770	PANEL, HDLP CVR-RH	20302392
36.	B11	12.810	PANEL, RF (EXC AD3)	20302390
37.	N21	7.631	SUPPORT, RR BPR FASCIA (1985-86)	10020479
	N21	7.631	SUPPORT, RR BPR FASCIA W/BRACKET (1987-88)	10055079

38.	N21	7.831	FASCIA, RR BPR (W/WU2 1985)(W/W69 1986-87)(*3)	10042563
	N21	7.631	FASCIA, RR BPR (2 8-9)(EXC WU2 1985)	10033956
	N21	7.831	FASCIA, RR BPR (2 5R)(1985)(EXC W69 1986)	10032433
	N21	7.831	FASCIA, RR BPR (2 5R)(EXC W69 1987)	10055053
	N21	7.831	FASCIA, RR BPR (1988)	10068911
39.	B15	12.940	FILLER, BK WDO FIL SI-RH (1985)	20680556
	B15	12.940	FILLER, R/WDO TO QTR OTR UPR SI-RH (1986-88)	20680556
	B15	12.940	FILLER, R/WDO TO QTR OTR UPR SI-LH	20680557
40.	B7	12.181	RETAINER, RR COMPT MTR CVR SI (1985-86)	20351044
	B7	12.181	RETAINER, RR COMPT MTR CVR SI (1987-88)	20513451
41.	B7	12.181	EXTENSION, MTR COMPT CVR SI-RH (INCL 51)	20667568
	B7	12.181	EXTENSION, MTR COMPT CVR SI-LH (INCL 51)	20667569
42.	N23	8.130	PANEL, FRT FDR-RH (1985-87)(DRILL AS REQD)	10077314
	N23	8.130	PANEL, FRT FDR-RH (1988)(*6)	10077314
	B12	12.695	PANEL, F/D OTR-RH	20882346
44.	B15	12.940	PANEL, QTR OTR LWR-RH	10077316
45.	B15	12.940	PANEL, QTR OTR UPR-RH (PART OF 3)	10077055
46.	B7	12.181	WASHER, RR COMPT MTR CVR SI PNL (PART OF 2 53)	20358301
47.	B7	12.181	FASTENER, RR COMPT MTR CVR GRL SI-RH(*8)	20580522
	B7	12.181	FASTENER, RR COMPT MTR CVR SI PNL-LH(*8)	20634111
48.	B7	12.181	RETAINER, RR COMPT MTR CVR GRL SI (PART OF 2 53)	20375013
49.	B8	12.183	WASHER, RR COMPT MTR CVR GRL (1985-87)(*7)	4462339
50.	N15	0.206	NUT, MTR CVR COMPT SI (1985-87)(*7)	20803557
51.	B9	12.184	BUMPER, MTR COMPT CVR SI (12 810)(PART OF 2 41 53)	20465423
52.	B7	12.181	FASTENER, RR COMPT MTR CVR GRL SI (1985-87)(*7)	20580522
53.	B7	12.181	PANEL, RR COMPT MTR CVR GRL SI-RH (INCL 46 48-52)(*1)	10054682
54.	B7	12.181	LID, RR COMPT LID (P37)	10077301
	B7	12.181	LID, RR COMPT LID (P37)	10077301
55.	B18	12.984	CLIP, B/W PNL FIL	20351041

NOTE 1: 1987 1ST DESIGN - MOUNTING HOLES ON FORWARD END OF PART ARE 290MM APART

NOTE 3: PAINT TO MATCH

NOTE 4: 1985 1ST DESIGN HAS "FIERO" LABEL

NOTE 5: 1985 2ND DESIGN DOES NOT HAVE "FIERO" LABEL

NOTE 6: CUT-OUTS ADDED TO ALLOW FOR POWER STEERING HOSES

NOTE 7: PART OF ITEMS 2 AND 53 FOR 1985-86 AND 1987 1ST DESIGN ASSEMBLY ONLY

NOTE 8: PART OF ITEMS 2 AND 53 FOR 1987 2ND DESIGN AND 1988 ASSEMBLY ONLY

2P12-301
122286

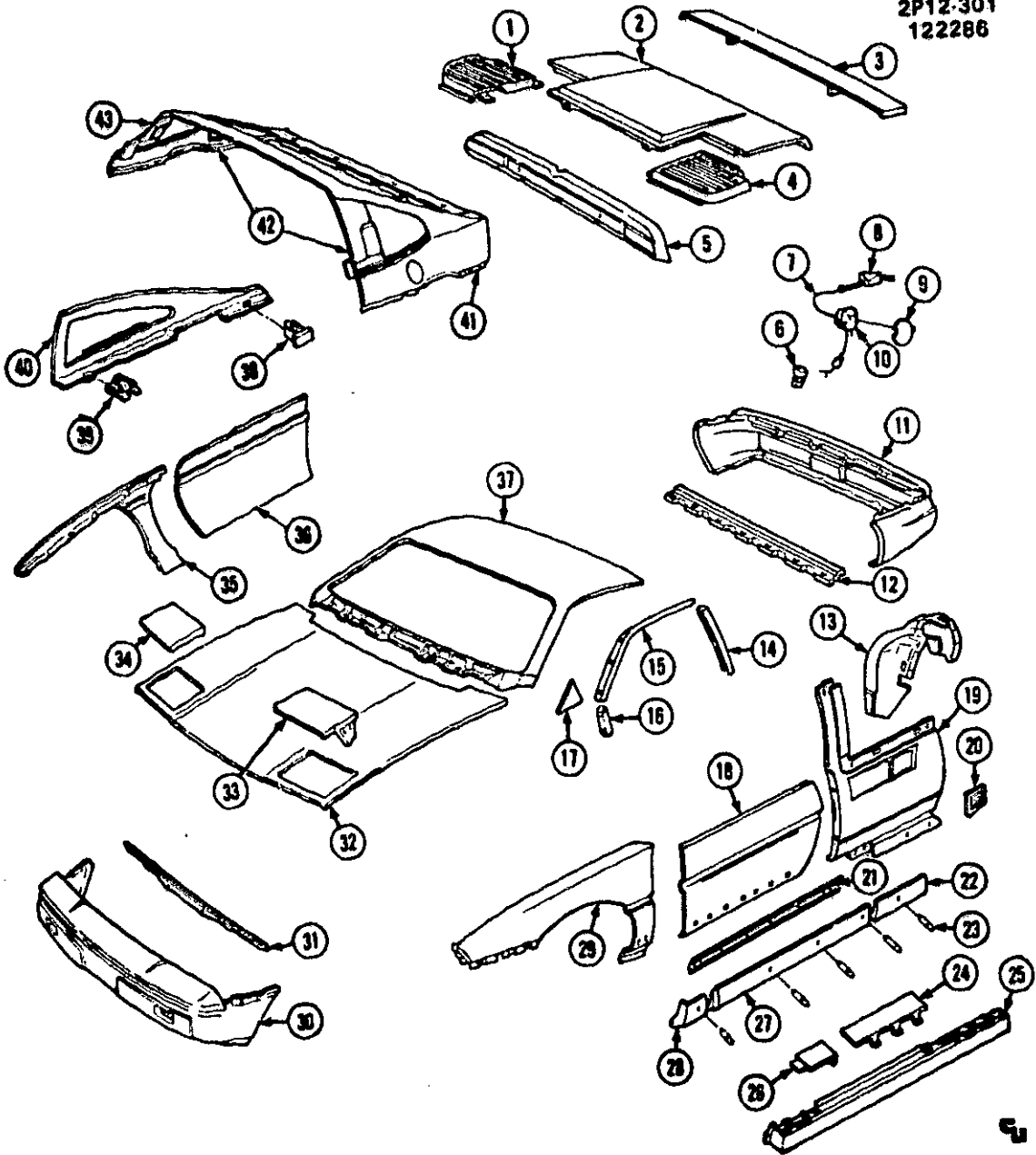

2P12-301

1986-1988 P97 BODY PLASTIC PARTS/EXTERIOR

1.	87	12.181	GRILLE, MTR COMPT SI OTR-RH (1986)	20898718
	87	12.181	GRILLE, MTR COMPT SI OTR-RH (1987 1ST DESK*3)	20898718
	87	12.181	GRILLE, MTR COMPT SI OTR-RH (1987 2ND DESK 1988K*3)	10054688
2.	87	12.181	LID, RR COMPT (1986-87)	10077303
	87	12.181	LID, RR COMPT (1988)	10077303
3.	87	12.181	SPOILER, RR COMPT LID AIR(*1)	10077408
4.	87	12.181	GRILLE, MTR COMPT SI OTR-LH (1986)	20861507
	87	12.181	GRILLE, MTR COMPT SI OTR-LH(*3)	10054688
5.		N.S.	PANEL, QTR INR UPR RR (PART OF 42)	20509500
6.	817	12.945	LATCH, FUEL FIL DR REM	10056571
7.	817	12.945	CABLE, REM REL FUEL FIL DR	20378281
8.	817	12.945	HANDLE, REM REL FUEL FIL DR	20861516
9.	817	12.945	DOOR, F/TK FIL	20861503
10.	817	12.945	POCKET, F/TK FIL	10088913
11.	N21	7.831	FASCIA, RR BPR (1986-87)	10088913
	N21	7.831	FASCIA, RR BPR (1988K*1)	10055079
12.	N21	7.831	SUPPORT, RR BPR FASCIA-W/BACKET	10077484
13.	816	12.944	PANEL, RR W/H LNR FRT-RH	10077488
	816	12.944	PANEL, RR W/H LNR RR-RH	10077488
	816	12.944	PANEL, RR W/H LNR FRT-LH	10077488
	816	12.944	PANEL, RR W/H LNR RR-LH	10077487
	813	12.934	RIVET, PNL W/H LNR FRT TO RR (8 133)	20433026
	816	12.944	RETAINER, W/H LNR (1 276)	20864092
14.	N28	10.721	RETAINER, BODY LK PLR-W/STRP-RH	20320548
	N28	10.721	RETAINER, BODY LK PLR-W/STRP-LH	20320549
15.	N28	10.721	RETAINER, W/S SI RF RL-RH (INCLS BLOW-OUT CLIP)	20320526
	N28	10.721	RETAINER, W/S SI RF RL-LH (INCLS BLOW-OUT CLIP)	20320527
16.	N28	10.695	RETAINER, F/D H/PLR UPR-W/STRP-RH	20320564
	N28	10.695	RETAINER, F/D H/PLR UPR-W/STRP-LH	20320565
17.	811	12.807	FILLER, W/S FRM AT BELT-RH	20894740
	811	12.807	FILLER, W/S FRM AT BELT-LH	20894741
18.	812	12.895	PANEL, F/D OTR-LH	20882347
19.	815	12.940	PANEL, QTR OTR LWR-RH(*4)	10077316
	815	12.940	PANEL, QTR OTR LWR-LH	20892099
20.	815	12.940	GRILLE, AIR INT	20478888
21.	813	12.934	SUPPORT, FRT S/D OTR LWR PNL	20609210
22.	813	12.934	PANEL, QTR OTR LWR FIN-RH	10074292
	813	12.934	PANEL, QTR OTR LWR FIN-LH	10074293
23.	88	12.118	RETAINER, RKR CVR PNL EXT DR PNL (PUSH-INX1 276)	20864092
24.	813	12.934	PLATE, RKR OTR PNL	20835057
25.	813	12.934	PANEL, RKR OTR-RH	10074288
	813	12.934	PANEL, RKR OTR-LH	10074287
26.	813	12.934	PLATE, RKR OTR CVR	20397143
27.	813	12.934	PANEL, FRT S/D OTR LWR-RH	10074280
	813	12.934	PANEL, FRT S/D OTR LWR-LH (1986-87)	10074291
28.	N23	8.131	PANEL, RKR CVR PNL TO F/FDR OTR PNL-RH	10074288
	N23	8.131	PANEL, RKR CVR PNL TO F/FDR OTR PNL-LH	10074289
29.	N23	8.130	PANEL, F/FDR-LH(*2)	20572975
30.	N21	7.831	FASCIA, FRT BPR	10088912
	N21	7.831	FASCIA, FRT BPR (W/W71 1988K*1)	10042562
31.	N21	7.831	REINFORCEMENT, FRT BPR FASCIA GRL OPG	10030837
32.	N23	8.000	HOOD	20816584
33.	N17	2.770	PANEL, HDLP CVR-LH	20302393
34.	N17	2.770	PANEL, HDLP CVR-RH	20302392
35.	N23	8.130	PANEL, F/FDR-RH (1986-87K*2)	10077314
	N23	8.130	PANEL, FRT FDR-RH(*4)	10077314
36.	812	12.895	PANEL, F/D OTR-RH	20882348
37.	811	12.810	PANEL, RF (EXC AD3)	20302390
	811	12.810	PANEL, RF (W/AD3)	20841470
38.	815	12.940	SPACER, B/W FIL TO Q/PNL	20834104
39.	815	12.940	SPACER, B/W TO QTR FIL MTG	20861501
40.	815	12.940	FILLER, R/WDO TO QTR FIL-RH	10074298
	815	12.940	FILLER, R/WDO TO QTR FIL-LH	10074297
41.	815	12.940	PANEL, QTR OTR UPR-LH (1986-88)	20894747
42.	815	12.940	PANEL, QTR OTR UPR (COMPL)(INCL 5)	10077317
43.	815	12.940	PANEL, QTR OTR UPR-RH	20894746

NOTE 1: PAINT TO MATCH.

NOTE 2: DRILL AS REQUIRED

NOTE 3: 1ST DESIGN MOUNTING HOLES ON FORWARD END OF PART ARE 140MM APART 2ND

DESIGN HOLES ARE 125MM APART

NOTE 4: CUT-OUTS ADDED TO ALLOW FOR POWER STEERING HOSES

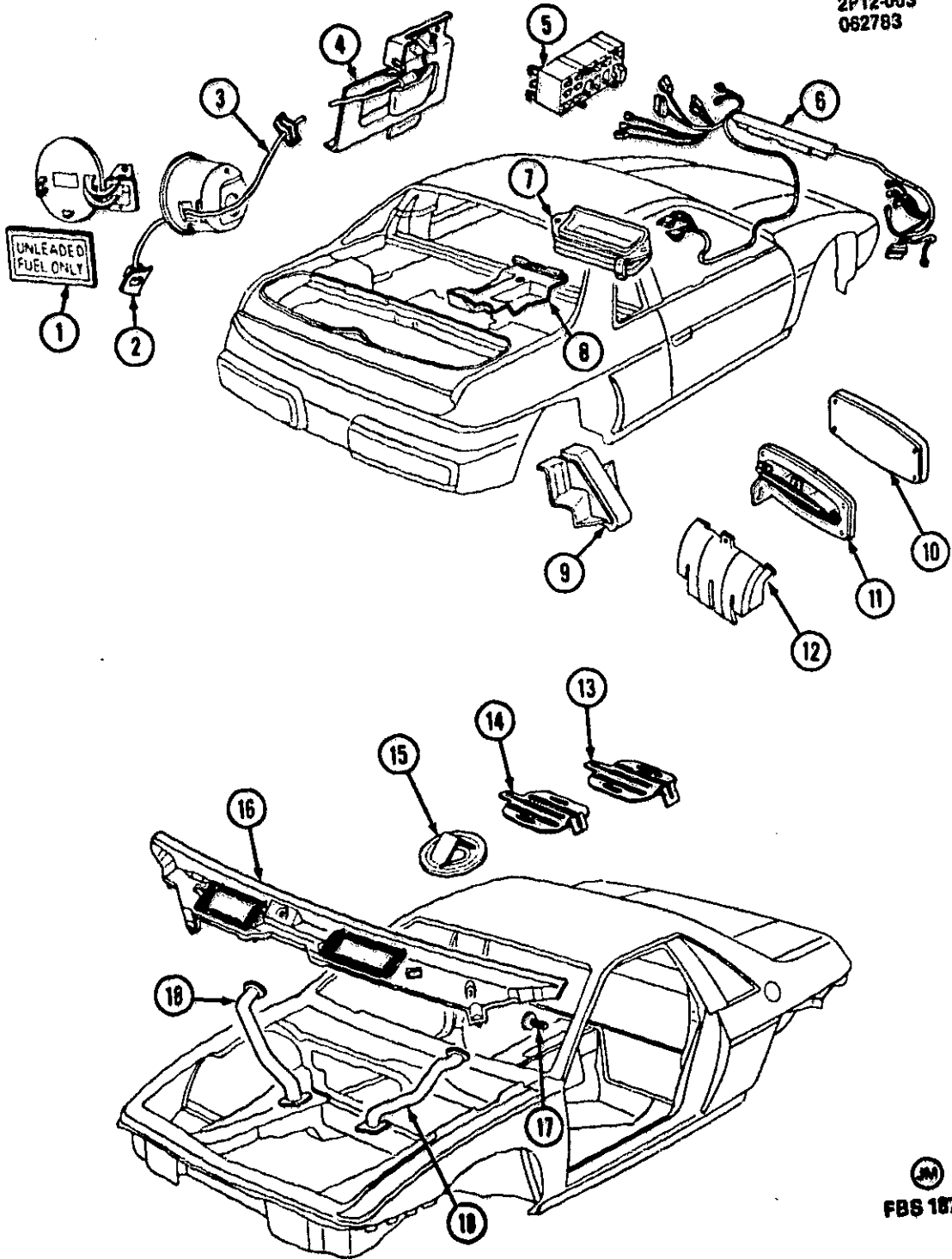

1984-1988 P DOOR HARDWARE/FUEL FILLER

NOTE FBS-1870

1.	N17	3.028	LABEL, FUEL "UNLEADED FUEL ONLY"	20337916
2.	B17	12.945	LATCH, FUEL FIL DR REM	20509500
3.	B17	12.945	CABLE, REM REL FUEL FIL DR (P37)	10056571
	B17	12.945	CABLE, REM REL FUEL FIL DR (P97)	10056571
4.	B17	12.945	HANDLE, REM REL FUEL FIL DR	20378261
5.	C5	13.100	CONNECTOR, WRG BODY TO INTERFACE (W/AU3.A31.C49.DG7)	20284814
6.	N16	2.480	HARNESS, WRG (1984)	12043182
	N16	2.480	HARNESS, WRG (1985)	12049676
	N16	2.480	HARNESS, WRG (1986)	12051892
	N16	2.480	HARNESS, WRG (1987)	12059789
	N16	2.480	HARNESS, WRG (1988)	12076767
7.	B11	12.804	EXTENSION, SHRD TOP VENT (1984)	20516683
	B11	12.804	EXTENSION, SHRD TOP VENT (1985-88)	20511490
8.	N16	2.333	FASTENER, BAT HOLD DOWN	20489129
9.	B16	12.940	BAFFLE, QTR OTR TO MTR COMPT SI RL RH	20477508
	B16	12.940	BAFFLE, QTR OTR TO MTR COMPT SI RL LH	20477509
10.	N26	9.789	COVER, DUCT PNL RH	20314574
11.	N26	9.789	OUTLET, VENT DASH PNL (1984)	20307334
12.	B10	12.850	EXTENSION, DASH PNL VENT OUTLET (1984)	20363496
13.	B18	12.981	COVER, DRN HOLE (1985-88)	20579955
14.	B18	12.981	COVER, RR COMPT FLR DRN HOLE	20346029
15.	B18	12.981	PLUG, DRN HOLE ON FLR PAN & W/H RR	10064426
16.	B10	12.800	SCREEN, SHRD TOP VENT (1984-85)	20559921
	B10	12.800	SCREEN, SHRD TOP VENT (1986-88)	10074271
17.	B10	12.800	FASTNER, TOP VENT TO RF PNL	20511451
18.	B11	12.804	HOSE, DRN SHRD TOP VENT DUCT-RH	20314576
	B11	12.804	HOSE, DRN SHRD TOP VENT DUCT-LH	20314577

2P12-001
113089

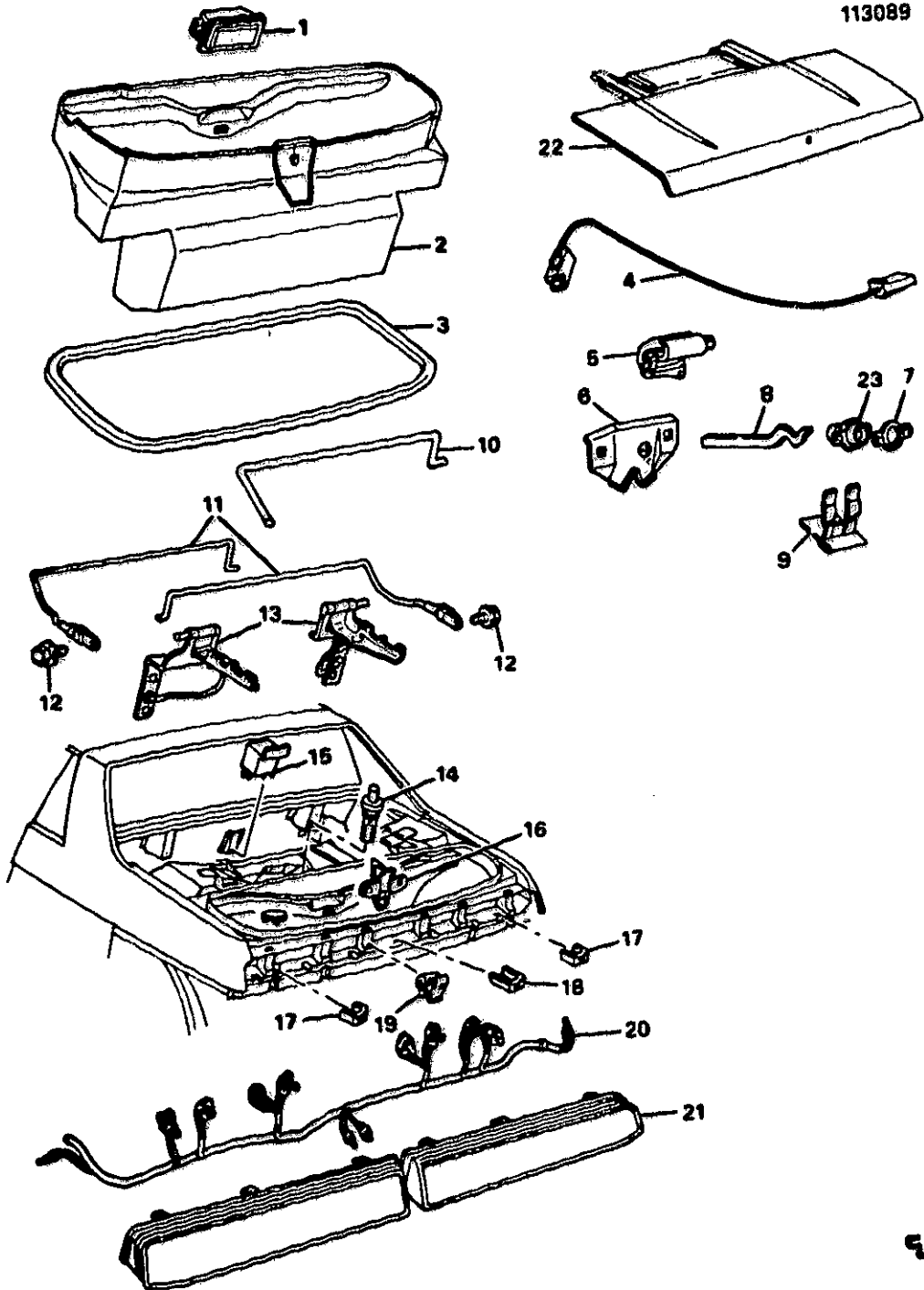

2P12-001

1984-1988 P REAR COMPARTMENT HARDWARE & TRIM

NOTE FBS-1863

1.	N26	9.988	LAMP, COMPT (11 927)	20471079
2.	E5	15.222	TRIM, COMPT. (SILVER GRAY) (1984KW/2 5R 1985-88)	20583401
3.	B10	12.269	WEATHERSTRIP, COMPT	20510193
4.	C4	13.090	HARNESS, LID LK (W/A90 1984-85)	20392798
	C4	13.090	HARNESS, LID LK (1986-88)	12046556
5.	B9	12.243	SOLENOID, LID LK (W/A90)	20052846
6.	B9	12.242	LOCK, LID (1984-86)	20166276
	B10	12.248	LOCK PKG, UNIV CODE (B&S 608483XP97 1987-88X*2)	20504690
	B10	12.248	LOCK, UNIV CODE (B&S 700588XP37 1987)	20504694
	B10	12.248	LOCK, UNIV CODE (P37 1988)	20504694
7.	B10	12.247	GASKET, LID LK CYL (1984)	20291394
	B10	12.247	GASKET, LID LK CYL (1985-88)	20529478
8.	B10	12.248	CYLINDER, LK (B&S 609412XBLACKX1984-87)	20498710
	B10	12.248	CYLINDER, LK (1988)	20498710
9.	B10	12.249	RETAINER, LID LK CYL (BLACK)	20371992
10.	B9	12.186	SILENCER, TORQ ROD HGE (1985-88)	20434780
11.	B9	12.187	ROD, TORQ RH (BLUEKW/V56.V58 EXC D80)	20355088
	B9	12.187	ROD, TORQ LH (BLUEKW/V56.V58 EXC D80)	20355089
12.	B9	12.184	BOLT, HGE (1984)	20456350
13.	B9	12.184	HINGE, COMPT RH	20548246
	B9	12.184	HINGE, COMPT LH	20548247
14.	N23	6.077	SWITCH, LID AJAR (11 950X1985-88X*3)	20546277
15.	N17	2.694	RELAY, LP (1984)	20480229
16.	B9	12.237	STRIKER, LATCH	20429148
17.	N17	2.679	STOP, T/LP END (BLACK)	20476978
18.	N17	2.679	STOP, T/LP CTR (BLACK)	20380245
19.	N17	2.684	CLIP, T/LP RET	20380246
20.	C4	13.090	HARNESS, COMPT (W/K34 1984)	20480232
	C4	13.090	HARNESS, COMPT (W/K34.2 5R 1985)	20481682
	C4	13.090	HARNESS, COMPT (W/U25.2 5R EXC K34 1985)	20481681
	C4	13.090	HARNESS, COMPT (W/K34.2 8-9 1985)	20803497
	C4	13.090	HARNESS, COMPT (P37 W/2 8-9 EXC K34.U25 1986XP37 W/K34.U25.2 5L 1986-87XP37 1988)	20624388
	C4	13.090	HARNESS, COMPT (P97 1986-88)	12067445
21.		N.S.	LAMP, COMB (PMX*1)	
		N.S.	LAMP, COMB (PGX*1)	
22.	B7	12.181	PANEL, RR COMPT LID (1984)	20483183
	B7	12.181	LID, RR COMPT LID (P37X*4)	10077301
	B7	12.181	LID, RR COMPT LID (P97 1986-87)	10077303
	B7	12.181	LID, RR COMPT LID (P97 1988)	10077303
23.	B10	12.252	SHAFT, RR COMPT LK (B&S 321370XP97X1986-88)	20585893
	B10	12.252	SHAFT, RR COMPT LID LK CYL (P37X1984-86)	20166681

NOTE 1 FOR DETAILS SEE REAR LAMP EXPLODED VIEW IN GROUP 2 000

NOTE 2 LOCK CONTAINS BOTH BRIGHT AND BLACK CASE CAP

NOTE 3 DOUBLE POLE

NOTE 4 22 5MM LOCK HOLE

PONTIAC BODY GROUP 14.000

ILLUSTRATION INDEX

TITLE	GRID
1984-1985 P TRIM/FRONT DOOR & QUARTER	15
1986-1988 P TRIM/FRONT DOOR & QUARTER	17
1984-1985 P SEAT ASM/FRONT (W/AR9)	19
1986-1988 P SEAT ASM/FRONT (W/AR9)	111
1988 P SEAT ASM/FRONT (W/AF9)	113
1986-1988 P SEAT BELT HARDWARE	114

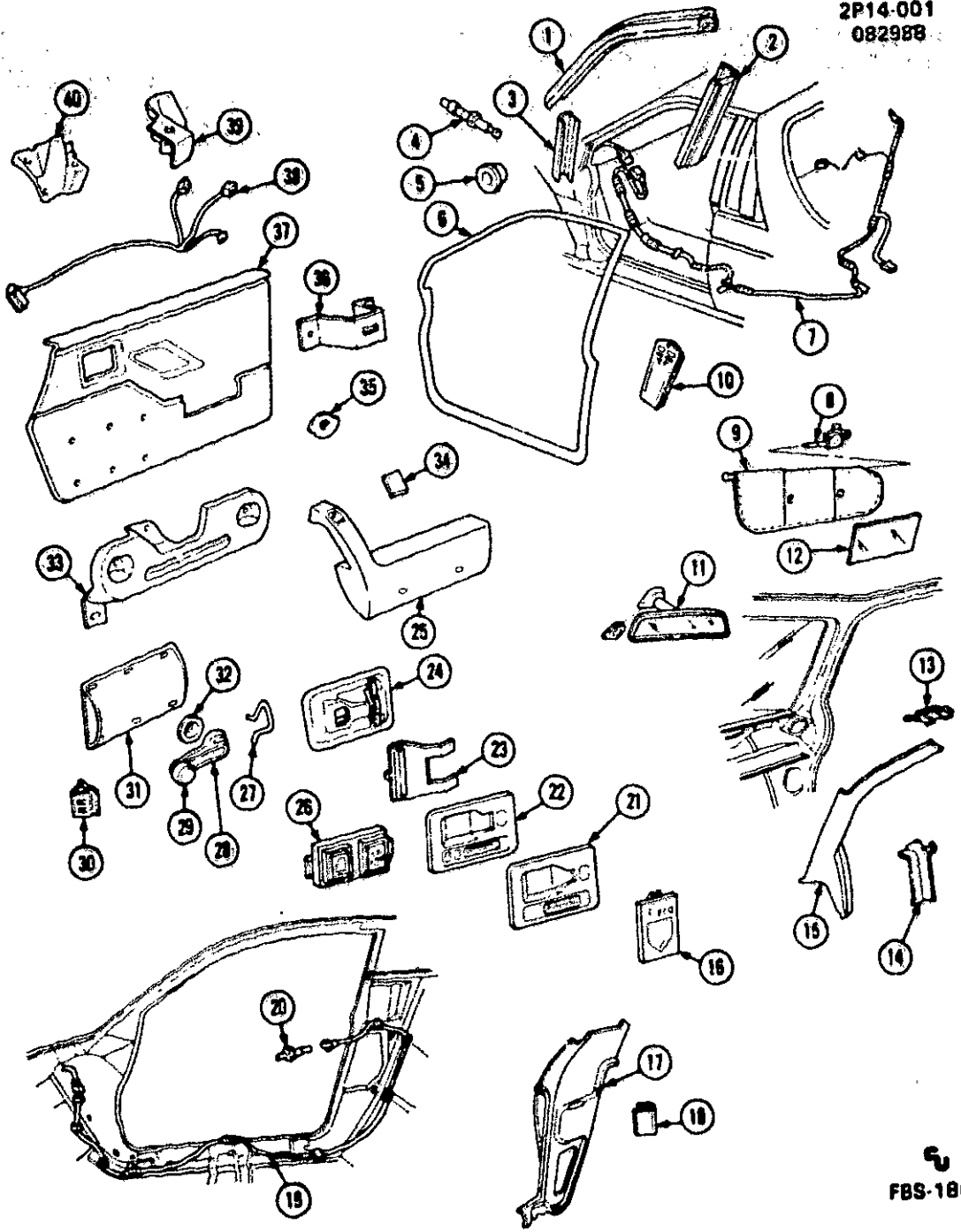

1984-1985 P TRIM/FRONT DOOR & QUARTER

NOTE FBS 1866

1.	N28	10.721	RETAINER, W/S SI RF RL RH	20320528
	N28	10.721	RETAINER, W/S SI RF RL LH	20320527
2.	N28	10.721	RETAINER, W/STR BODY LK PLR-RH	20320548
	N28	10.721	RETAINER, W/STR BODY LK PLR-LH	20320549
3.	N28	10.695	RETAINER, W/STR F/D H/PLR UPR-RH	20320584
	N28	10.695	RETAINER, W/STR F/D H/PLR UPR-LH	20320585
4.	A8	11.950	SWITCH, DR JAMB DBL POLE	20646277
5.	N28	10.778	PLUG, FRT BODY HGE PLR ELEC CDT	20424307
6.	N28	10.694	WEATHERSTRIP, DR(COMPL)-RH	20510236
	N28	10.694	WEATHERSTRIP, DR(COMPL)-LH	20510237
7.	C4	13.090	HARNNESS, DR ADJR & ST BLT & PRK BRK	20320666
8.	N27	10.219	SUPPORT, S/S	20394688
9.	N27	10.203	SUNSHADE, (13C DXW/DB4X*2)	20561122
10.		N.S.	VALVE, RLF BODY LK PLR PRESS	
11.	N26	10.185	MIRROR, 1/S RR VIEW	918583
12.	N27	10.195	MIRROR, S/S VAN (BLACK)W/D34X*1)	1741050
13.	N26	10.058	CLIP, MLDG TO RF RL	20424242
14.	N26	10.051	MOLDING, W/S SI LWR-RH(*1)	20479018
	N26	10.051	MOLDING, W/S SI LWR-LH(*1)	20827103
15.	N26	10.051	MOLDING, W/S SI UPR-RH(*1)	20592080
	N26	10.051	MOLDING, W/S SI UPR-LH(*1)	20592081
16.	N27	10.515	COVER, CUP F/D LK REM HDL	20484801
17.	E5	15.100	PANEL, TR QTR-RH(*1)	20481242
	E5	15.100	PANEL, TR QTR-LH(*1)	20481243
18.	E5	15.100	RETAINER, TR PNL QTR(*1)	20452689
19.	C4	13.090	HARNNESS, DR AJAR	20320664
20.	A8	11.950	SWITCH, DR AJAR (8.077)	20555200
21.	N27	10.515	CUP, F/D LK R/CONT HDL-RH (EXC AU3)	20330568
	N27	10.515	CUP, F/D LK R/CONT HDL-LH (EXC AU3)	20330569
22.	N27	10.515	CUP, F/D LK R/CONT HDL & SW-RH (W/AU3)INCL 26)	20352612
	N27	10.515	CUP, F/D LK R/CONT HDL & SW-LH (W/AU3)INCL 26)	20352613
23.	N27	10.512	HANDLE, F/D LK R/CONT (1984)	20351005
	N27	10.512	HANDLE, F/D LK R/CONT (1985)	20531544
24.	N27	10.515	ESCUTCHEON, F/D LK R/CONT HDL	20208202
25.	D11	14.686	ARM REST, F/D-RH (13B-C DX*2)	20444032
	D11	14.686	ARM REST, F/D-LH (13B-C DX*2)	20444033
26.	N27	10.485	SWITCH, LK-RH (W/AU3)PART OF 22)	20344292
	N27	10.485	SWITCH, LK-LH (W/AU3)PART OF 22)	20344293
27.	N28	10.806	SPRING, F/D WDO REG HDL RET (PART OF 28)	4169122
28.	N28	10.797	HANDLE, WDO REG (INCL 27 & 29)	20315735
29.		N.S.	KNOB, HDL (PART OF 28)	
30.	D10	14.683	CLIP, DR TR PNL MAP PKT LH (W/BC8)	20487919
31.	D11	14.692	POCKET, F/D MAP TR PNL (64B-C D 643XW/BC8X*2)	20597165
32.	N28	10.606	PLATE, F/D WDO REG HDL BRG	20375300
33.	D11	14.690	PLATE, F/D A/RST LWR HNGR-RH	20429340
	D11	14.690	PLATE, F/D A/RST LWR HNGR-LH	20429341
34.	D11	14.686	PLUG, F/D A/RST-RH(*1)	20491366
	D11	14.686	PLUG, F/D A/RST-LH(*1)	20491367
35.	D11	14.686	NUT, HNGR PLT TO A/RST (1984)	20338401
	D11	14.690	NUT, HNGR PLT TO A/RST (1985)	20310739
36.	D11	14.690	PLATE, F/D A/RST UPR HNGR	20429342
37.	D10	14.685	TRIM, DR-RH (13B-C DX*2)	20440302
	D10	14.685	TRIM, DR-LH (13B-C DX*2)	20440303
38.	C4	13.090	HARNNESS, DR(COMPL)-RH (W/AU3 A31)	20320658
	C4	13.090	HARNNESS, DR(COMPL)-LH (W/AU3 A31)	20320659
39.	N28	10.694	WEATHERSTRIP, DR LK PLR AT BELT RH	20320562
	N28	10.694	WEATHERSTRIP, DR LK PLR AT BELT LH	20320563
40.	N28	10.694	WEATHERSTRIP, DR HGE PLR AT BELT-RH	20320560
	N28	10.694	WEATHERSTRIP, DR HGE PLR AT BELT-LH	20320561

NOTE 1 PRIME AND PAINT

NOTE 2 SEE PARTS CATALOG FOR ADDITIONAL COLORS AND TRIM COMBINATIONS

2P14-003
090188

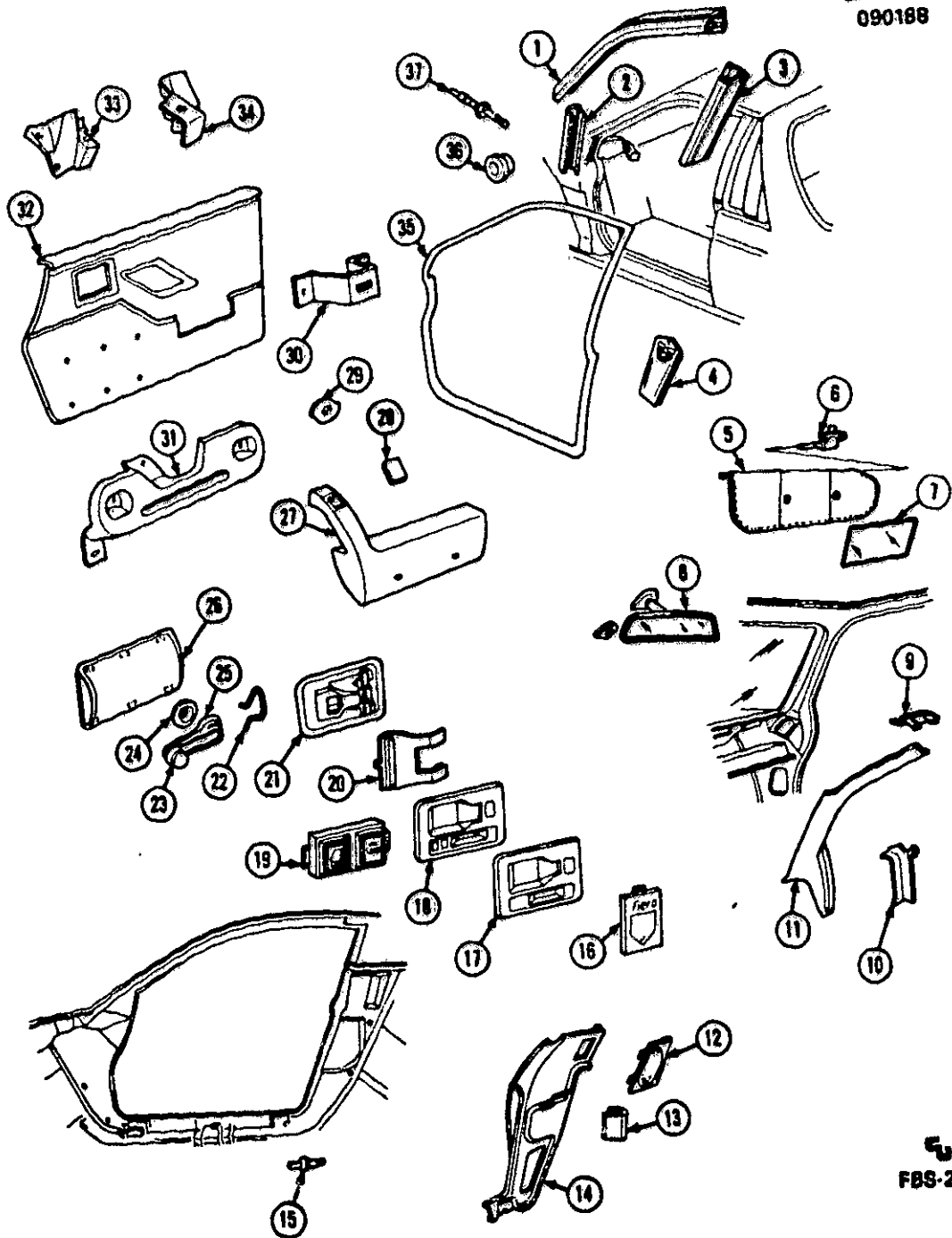

FBS-2207

2P14-003

1986-1988 P TRIM/FRONT DOOR & QUARTER

NOTE FBS-2207

1.	N28	10.721	RETAINER, W/S SI RF RL RH	20320526
	N28	10.721	RETAINER, W/S SI RF RL LH	20320527
2.	N28	10.695	RETAINER, W/STR DR H/PLR UPR-RH	20320564
	N28	10.695	RETAINER, W/STR DR H/PLR UPR-LH	20320565
3.	N28	10.721	RETAINER, W/STR BODY LK PLR-RH	20320548
	N28	10.721	RETAINER, W/STR BODY LK PLR-LH	20320549
4.	B15	12.942	VALVE, RLF BODY PLR PRESS	1745535
5.	N27	10.203	SUNSHADE, (MED DK GRAY-82D-I-822)(PGKPM W/DB4 1986-87)(*)	20511253
	N27	10.203	SUNSHADE, (MED DK GRAY 82B-I)(KPM EXC DB4 1986-87)(KPM 1988)(*)	20511255
6.	N27	10.219	SUPPORT, S/S (BLACK)	20394558
7.	N27	10.195	MIRROR, S/S VAN (W/D34)(*)	1741950
8.	N26	10.185	MIRROR, 1/S RR VIEW (1986)	918556
	N26	10.185	MIRROR, 1/S RR VIEW (1987-88)	10078250
9.	N26	10.056	CLIP, MLDG TO RF RL (BLACK)	20424242
10.	N26	10.051	MOLDING, W/S SI LWR-RH(*)	20479018
	N26	10.051	MOLDING, W/S SI LWR-LH(*)	20627103
11.	N26	10.051	MOLDING, W/S SI UPR-RH(*)	20681626
	N26	10.051	MOLDING, W/S SI UPR-LH(*)	20681627
12.	N25	9.655	SPEAKER, QTR (W/U66)	16048242
	N25	9.655	SPEAKER, QTR UPR (W/U06)	16048242
13.	E5	15.100	RETAINER, TR PNL QTR(*)	20522937
14.	E5	15.100	PANEL, TR QTR-RH(*)	20553955
	E5	15.100	PANEL, TR QTR-LH(*)	20553957
15.	A8	11.950	SWITCH, DR JAMB (DBL POLE)	20545277
16.	N27	10.515	COVER, CUP DR LK REM HDL	20484501
17.	N27	10.515	CUP, DR LK R/CONT HDL-RH (EXC AU3)	20330555
	N27	10.515	CUP, DR LK R/CONT HDL-LH (EXC AU3)	20330559
18.	N27	10.515	CUP, DR LK R/CONT HDL & SW-RH (W/AU3)(INCL 19)	20352612
	N27	10.515	CUP, DR LK R/CONT HDL & SW-LH (W/AU3)(INCL 19)	20352613
19.	N27	10.485	SWITCH, DR LK-RH (W/AU3)(PART OF 18)	20344292
	N27	10.485	SWITCH, DR LK-LH (W/AU3)(PART OF 18)	20344293
20.	N27	10.515	ESCUTCHEON, DR LK R/CONT HDL (BLOCKOUT)	20205202
21.	N27	10.512	HANDLE, DR LK R/CONT	20531544
22.	N26	10.805	SPRING, DR WDO REG HDL RET (10 805)(PART OF 25;	4168122
23.		N.S.	KNOB, DR HDL (PART OF 25)	
24.	N26	10.805	PLATE, DR WDO REG HDL BRG (BLACK)	20375300
25.	N20	10.797	HANDLE, DR WDO REG (BLACK DULL)(INCL 22 & 23)	20315735
26.	D11	14.692	POCKET, DR TR PNL MAP (MED DK GRAY 822)(HW/BC8 1986)(*)	20807705
	D11	14.692	POCKET, DR TR PNL MAP (MED DK GRAY 82B-I-822)(PG 1987 88)(KPM W/BC8 1987-88)(*)	10125113
27.	D11	14.686	ARMREST, DR-RH (MED DK GRAY 82B-D-I-822)(*)	20822940
	D11	14.686	ARMREST, DR-LH (MED DK GRAY 82B-D-I-822)(*)	20822941
28.	D11	14.686	PLUG, DR A/RST RH(*)	20491366
	D11	14.686	PLUG, DR A/RST LH(*)	20491367
29.	D11	14.690	NUT, HNGR PLT TO A/RST	20310739
30.	D11	14.690	PLATE, FRT A/RST UPR HNGR	20429342
31.	D11	14.690	PLATE, FRT A/RST LWR HNGR-RH	20429340
	D11	14.690	PLATE, FRT A/RST LWR HNGR-LH	20429341
32.	D10	14.685	TRIM, DR-RH (MED DK GRAY-82B-D-I-822)(*)	20590954
	D10	14.685	TRIM, DR-LH (MED DK GRAY-82B-D-I-822)(*)	20590955
33.	N28	10.684	WEATHERSTRIP, DR HGE PLR AT BELT-RH	20320560
	N28	10.684	WEATHERSTRIP, DR HGE PLR AT BELT-LH	20320561
34.	N28	10.684	WEATHERSTRIP, DR LK PLR AT BELT-RH	20320562
	N28	10.684	WEATHERSTRIP, DR LK PLR AT BELT-LH	20320563
35.	N28	10.694	WEATHERSTRIP, DR (COMPL)-RH	20510236
	N28	10.694	WEATHERSTRIP, DR (COMPL)-LH	20510237
36.	N28	10.778	PLUG, FRT BODY HGE PLR ELEC CDT HOLE-LH	20424307
37.	A8	11.950	SWITCH, DR JAMB DBL POLE	20545277

NOTE 1 SEE PARTS CATALOG FOR ADDITIONAL COLORS AND TRIM COMBINATIONS

NOTE 2 PRIME AND PAINT TO MATCH

2P14-002
110786

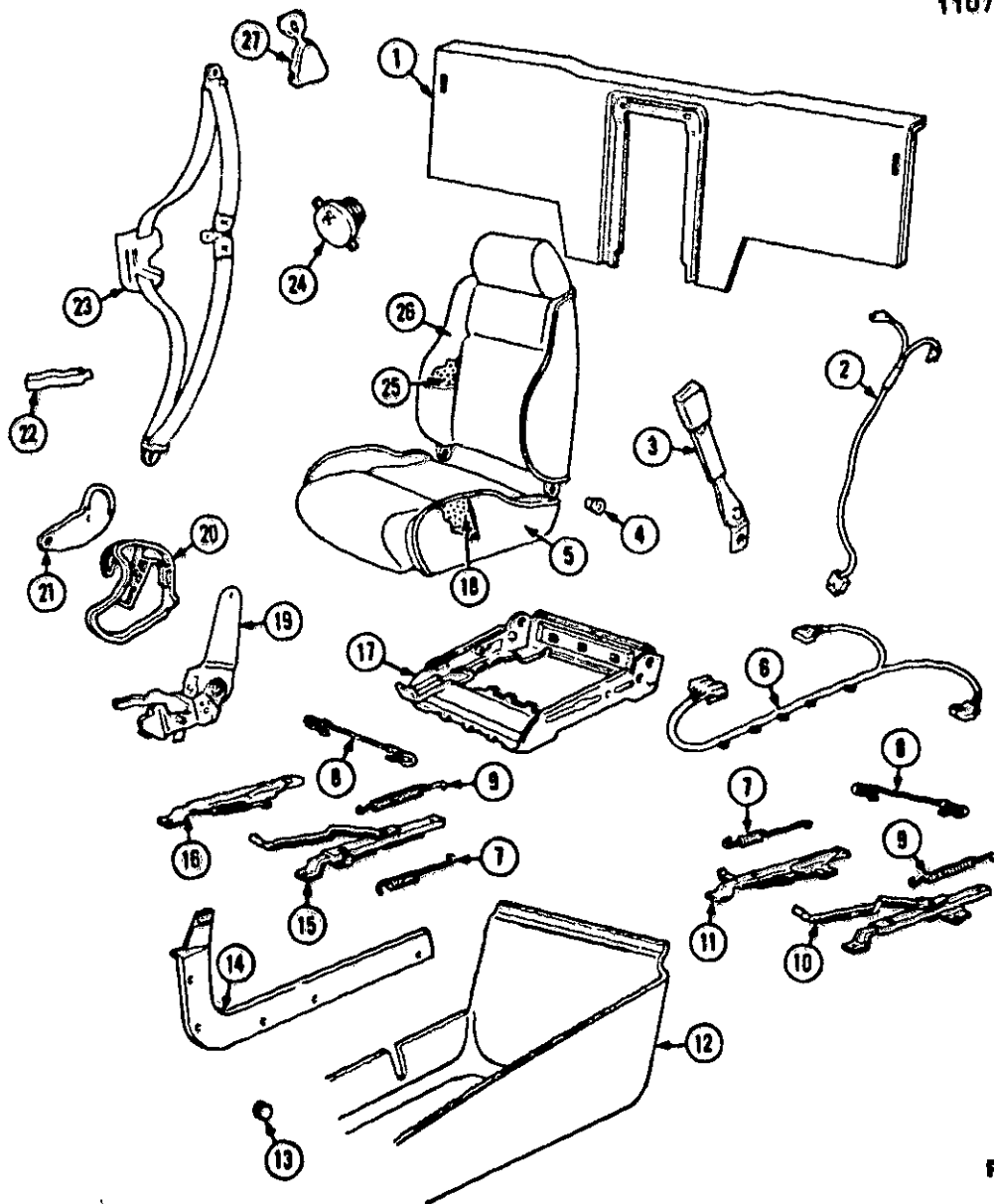

FBS 1867

2P14-002

1984-1985 P SEAT ASM/FRONT (W/AR9)

NOTE FBS-1867

1.		N.S.	PANEL, ST BK TO MTR COMPT (GRAPHITE 13B-C-D)	
		N.S.	PANEL, ST BK TO MTR COMPT (MED DOESKIN-64B-C-D 643)	
2.	N25	9.656	HARNESB, ST STEREO IN ST (1984 W/UP8)	20456401
3.	D12	14.876	BELT, F/ST BKL SI (LT SLATE GRAY)*1)	
4.	A5	11.375	BUSHING, ST HGE INR/OTR PIV	14059235
5.		N.S.	COVER, ST CUSH (GRAPHITE-13CX1984X*2)	
		N.S.	COVER, ST CUSH (GRAPHITE-13CX1985X*2)	
6.	N25	9.656	HARNESB, ST STEREO FRT (1984 W/UP8X1985 W/UW5)	20423466
7.	A7	11.561	SPRING, ST ADJ ASST (MANUALXW/UP8)	20371050
8.	A7	11.569	WIRE, ST ADJ AUX LKG (W/UP8)	20287962
9.	A7	11.561	SPRING, P/ST INR ADJ LK BAR (1984)	20010783
10.	A7	11.561	ADJUSTER, D/ST OTR (1984 W/UP8X1985)	20430313
11.	A7	11.561	ADJUSTER, D/ST INR (1984 W/UP8X1985)	20430312
12.	E5	15.288	CARPET, FLR-RH (GRAPHITE-13B-C DX*2)	10089480
	E5	15.288	CARPET, FLR-LH (GRAPHITE-13B-C DX*2)	10089481
13.	N27	10.515	PLUG, F/D LK R/CON HDL TO CUP(*3)	20454581
14.	A5	11.175	RETAINER, CPT F/D OPG ON RKR-RH (GRAPHITE-13B-C DX*2)	20452686
	A5	11.175	RETAINER, CPT F/D OPG ON RKR-LH (GRAPHITE 13B-C DX*2)	20512500
15.	A7	11.561	ADJUSTER, P/ST INR (1984 W/UP8X1985 W/UW5)	20430310
16.	A7	11.561	ADJUSTER, P/ST OTR (1984 W/UP8X1985 W/UW5)	20430311
17.	A6	11.419	FRAME, ST BTM (1984)	20423673
	A6	11.419	FRAME, ST BTM (1985)	20538985
18.	D17	14.890	PAD, ST BTM FRM (1984)	20488578
	D17	14.890	PAD, ST BTM FRM (1985)	20488578
19.	A5	11.377	CONTROL, P/ST BK RECL (W/UW5,AF9)	20672856
	A5	11.377	CONTROL, D/ST BK RECL (W/UW5)	20672857
20.	A5	11.377	COVER, P/ST BK RECL HGE LWR(*3)	20596788
	A5	11.377	COVER, D/ST BK RECL HGE LWR(*3)	20596789
21.	A5	11.377	PROTECTOR, P/ST CONT RECL BK(*3)	20366004
	A5	11.377	PROTECTOR, D/ST CONT RECL BK(*3)	20366005
22.	A5	11.377	KNOB, RECL REL HDL P/ST BK (BLACKXW/AF9)	20447343
	A5	11.377	KNOB, RECL REL HDL D/ST BK (BLACKXW/UP8)	20447344
23.	D12	14.875	BELT, ST RETR SI(*1)	
24.	N25	9.655	SPEAKER, ST H/RST	16033292
25.	D12	14.802	PAD, P/ST BK & PNL-RH (1984 EXC UP8X1985 EXC UW5)	20424956
	D12	14.802	PAD, D/ST BK & PNL-LH (1984 EXC UP8X1985 EXC UW5)	20424957
		N.S.	PAD, P/ST BK & PNL-RH (1984 W/UP8X1985 W/UW5)	
		N.S.	PAD, D/ST BK & PNL-LH (1984 W/UP8X1985 W/UW5)	
26.		N.S.	COVER, ST BK (GRAPHITE 13BX*2)	
27.	D12	14.875	COVER, F/ST BELT GDE ON OTR(*3)	20688520

NOTE 1 SEE CHART IN GROUP FOR USAGE

NOTE 2 SEE PARTS CATALOG FOR ADDITIONAL COLORS AND TRIM COMBINATIONS

NOTE 3 PAINT TO MATCH

2P14-004
020188

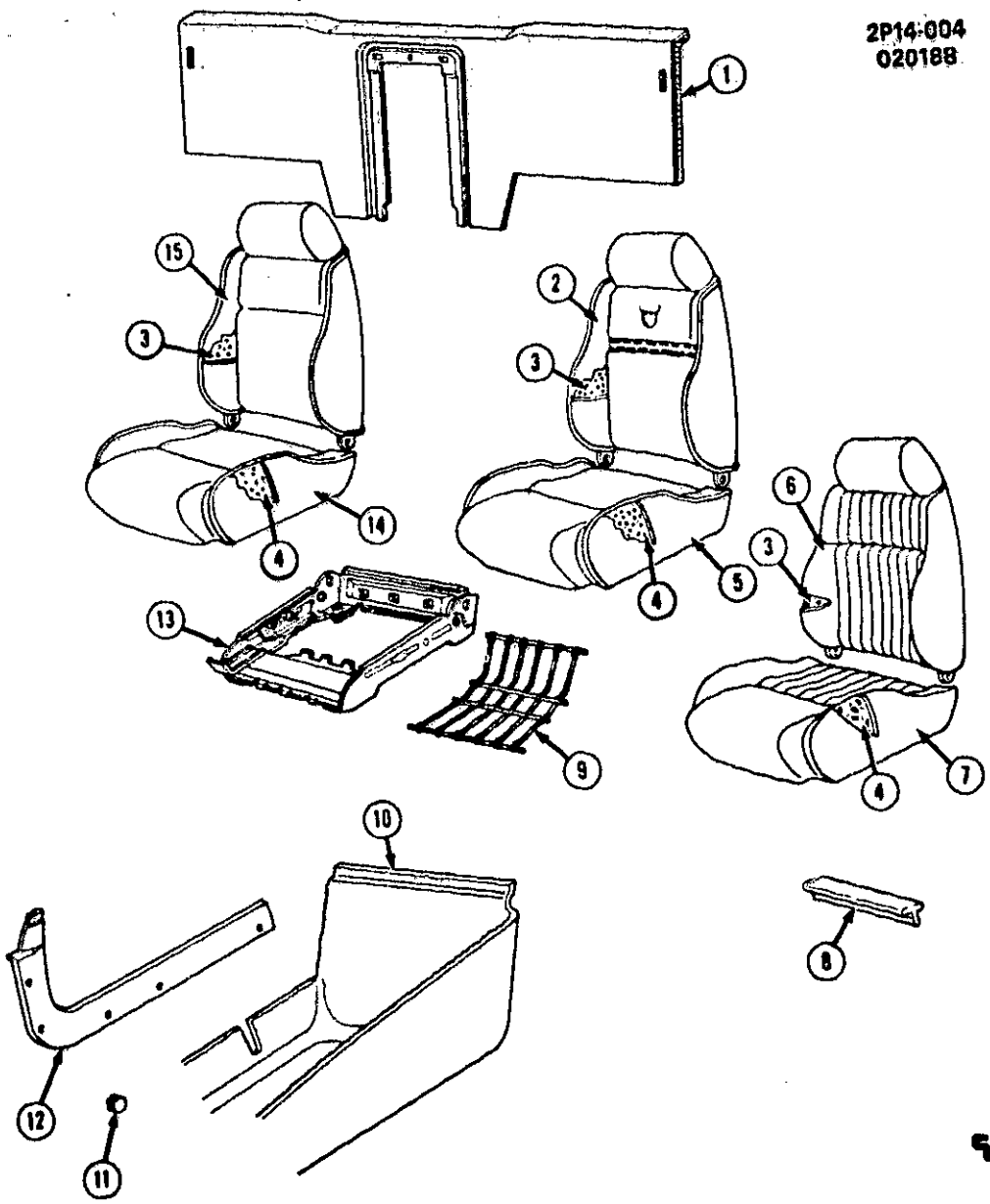

1986-1988 P SEAT ASM/FRONT (W/AR9)

NOTE FBS-2206

1.	E5	15.222	PANEL, ST BK TO MTR COMPT (MED DK GRAY 82B-D-1822X*1)	20881646
2.	D12	14.800	COVER, ST BK (MED DK GRAY 82DX1986-87X*1)	20634242
3.	D12	14.802	PAD, P/ST BK & PNL	20424956
	D12	14.802	PAD, D/ST BK & PNL	20424957
4.	D17	14.890	PAD, ST BTM FRM (1986-87)	20488578
	D17	14.890	PAD, ST BTM FRM (1988)	12391639
5.	D16	14.880	COVER, ST CUSH (MED DK GRAY 82DX1986-87X*1)	20501357
6.	D12	14.800	COVER, ST BK (MED DK GRAY 82DX1988X*1)	17950852
7.	D16	14.880	COVER, ST CUSH (MED DK GRAY 82DX1988X*1)	17950854
8.		N.S.	DEFLECTOR, ST BTM HT (1988)	
9.	A6	11.419	SUPPORT, ST BTM PAD (PART OF 13)	20284901
10.	E5	15.288	CARPET, FLR-RH (DK SADDLE 62B-D-622X1986-87X*1)	20581855
	E5	15.288	CARPET, FLR-LH (DK SADDLE 62B-D-622X1986-87X*1)	20581853
	E5	15.288	CARPET, FLR-RH (MED BEECHWOOD 66IX1988X*1)	10080080
	E5	15.288	CARPET, FLR-LH (MED BEECHWOOD 66IX1988X*1)	10080091
11.	E9	15.300	PLUG, FIN CPT RET (10 515X*2)	20454881
12.	A5	11.175	RETAINER, CPT F/D OFG ON RKR RH (MED DK GRAY 82B-D-1822X*1)	20622931
	A5	11.175	RETAINER, CPT F/D OPG ON RKR LH (MED DK GRAY 82B-D-1822X*1)	20622933
13.	A6	11.419	FRAME, ST BTM COMPL (INCL 9)	20538985
14.	D16	14.880	COVER, ST CUSH (MED DK GRAY 822X1986-87X*1)	17940988
	D16	14.880	COVER, ST CUSH (MED DK GRAY 82BX1988X*1)	17953194
15.	D12	14.800	COVER, ST BK (MED DK GRAY 822X1986-87X*1)	17940959
	D12	14.800	COVER, ST BK (MED DK GRAY 82BX1988X*1)	17953192

NOTE 1: SEE PARTS CATALOG FOR ADDITIONAL COLORS AND TRIM COMBINATIONS

NOTE 2: PAINT TO MATCH

2P14-301
021088

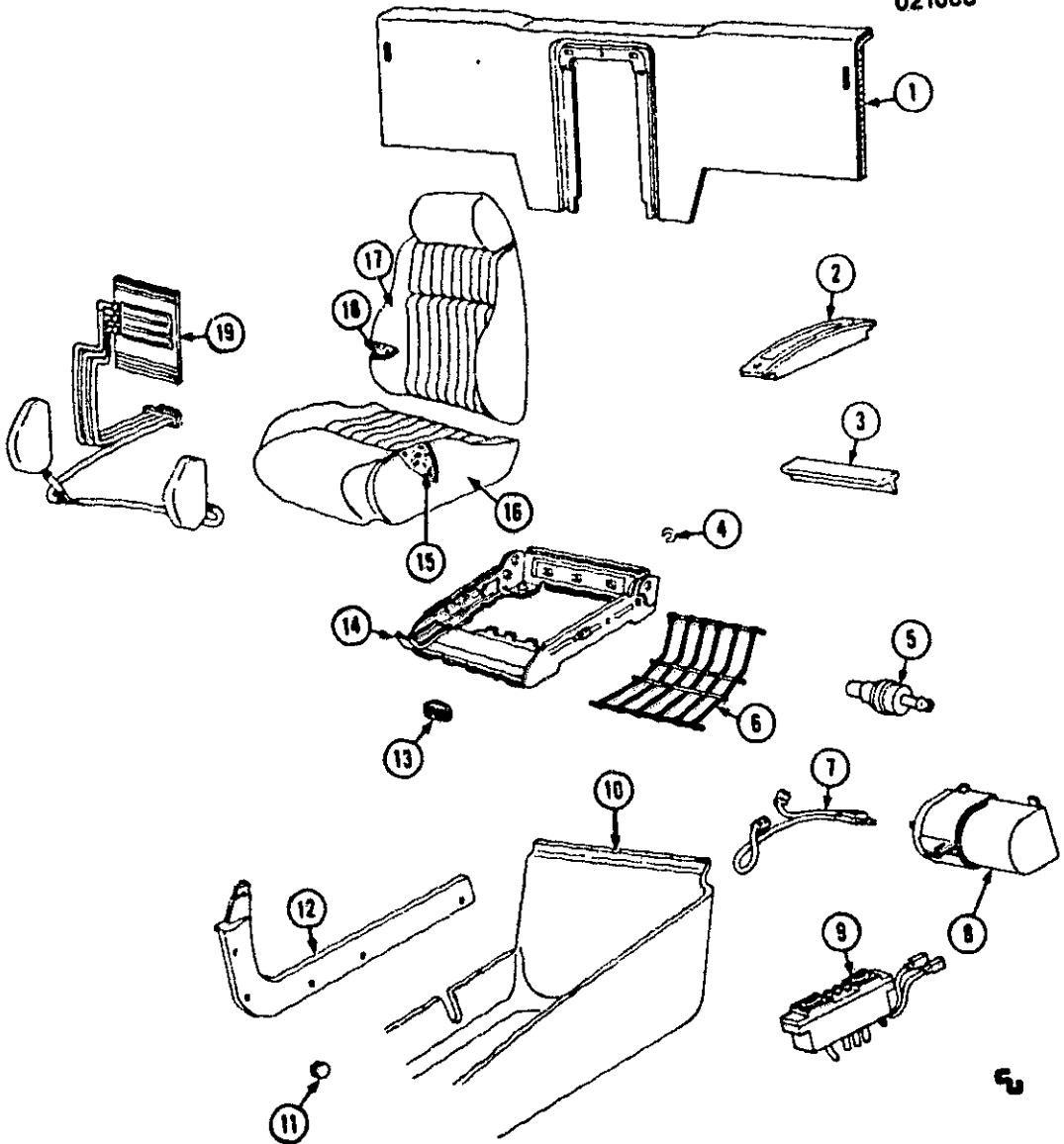

2P14-301

1988 P SEAT ASM/Front (W/AF9)

1.	E5	15.222	PANEL, ST BK TO MTR COMPT (MED DK GRAY 82I)(*1)	20881848
2.	A7	11.558	ESCUTCHEON, D/ST CUSH SW	20503130
3.		N.S.	DEFLECTOR, ST BTM HT	
4.	A6	11.373	RING, HOG	4876488
5.	A6	11.378	VALVE, D/ST AIR RELIEF	12391528
6.	A6	11.419	SUPPORT, ST BTM PAD (PART OF 14)	20284901
7.	C4	13.080	HARNES, D/ST WRG PWR TO SW PUMP	12391527
8.	A6	11.378	PUMP, D/ST AIR W/BRKT & HARN	12391530
9.	A6	11.378	SWITCH, D/ST W/CONN AND PNEU HARN	12391531
10.	E5	15.286	CARPET, FLR-RH (MED BEECHWOOD 66IX*1)	10080080
	E5	15.286	CARPET, FLR-LH (MED BEECHWOOD 66IX*1)	10080091
11.	E6	15.300	PLUG, FIN CPT RET (10 515X*2)	20454881
12.	A5	11.175	RETAINER, CPT F/D OPG ON RKR-RH (MED DK GRAY 82IX*1)	20622931
	A5	11.175	RETAINER, CPT F/D OPG ON RKR-LH (MED DK GRAY 82IX*1)	20622933
13.	A6	11.419	GROMMET, D/ST CUSH	20502082
14.	A6	11.419	FRAME, ST BTM COMPL (INCL 6)	20538985
15.	A6	11.419	FRAME, P/ST BTM FRM	12391539
	D17	14.890	PAD, D/ST CUSH (W/SW SUPT BRKT)	12391526
	D17	14.890	PAD, D/ST CUSH (LESS SW SUPT BRKT)	20503131
16.	D16	14.880	COVER, ST CUSH (MED DK GRAY 82DX*1)	17950854
17.	D12	14.800	COVER, ST BK (MED DK GRAY 82DX*1)	17950852
18.	D12	14.802	PAD, P/ST BK & PNL	20424956
	A5	11.373	PAD, D/ST BK FRM	12391520
19.	A6	11.378	BLADDER, W/HARN BOLSTER LUMBAR	12391529

NOTE 1 SEE PARTS CATALOG FOR ADDITIONAL COLORS AND TRIM COMBINATIONS

NOTE 2 PAINT TO MATCH

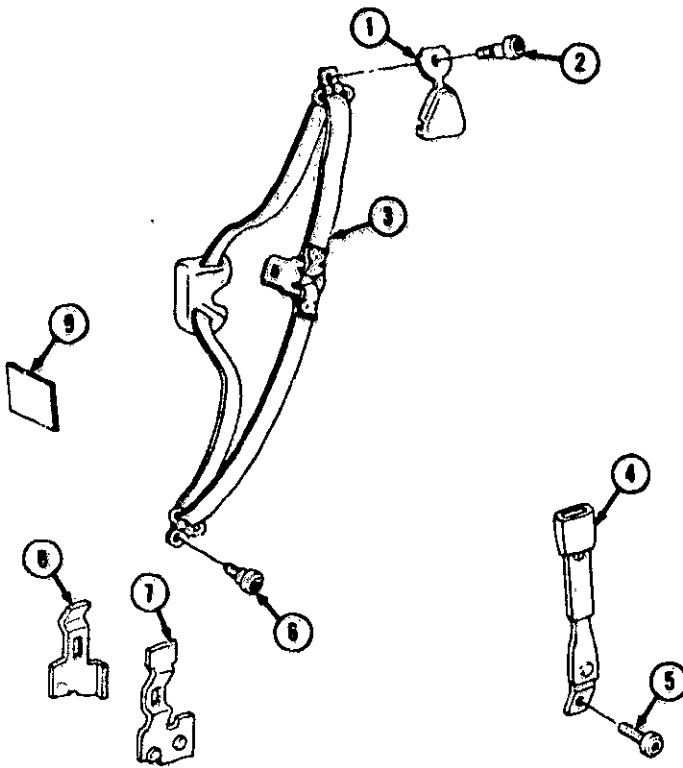

2P14-300

1986-1988 P SEAT BELT HARDWARE

- | | | | |
|----|-----|--------|-------------------------------------|
| 1. | D12 | 14.875 | COVER, ST BELT GDE ON OTR |
| 2. | D12 | 14.875 | BOLT, ST BELT TO LK PLR ANC PLT GDE |
| 3. | D12 | 14.875 | BELT, ST RETR SI |
| 4. | D12 | 14.875 | BELT, ST BKL SI |
| 5. | D12 | 14.875 | BOLT, ST BELT TO ANC PLT OTR |
| 6. | D12 | 14.875 | BOLT, ST BELT TO ANC PLT INR |
| 7. | D12 | 14.875 | BRACKET, ST BELT ANC-LH (3 015) |
| 8. | D12 | 14.875 | BRACKET, ST BELT ANC-RH (3 015) |
| 9. | D12 | 14.875 | SEALING STRIP, ST BELT |